

SHOCK RESPONSE SPECTRUM TESTING FOR COMMERCIAL PRODUCTS

Revision C, By Tom Irvine. E-mail: tomirvine@aol.com

INTRODUCTION

Mechanical shock can cause electronic components to fail. Crystal oscillators may shatter, for example. Components such as DC-to-DC converters can detach from circuit boards. Housings and other mechanical parts may develop fatigue cracks, even those made from metal. Mechanical shock can cause temporary malfunctions in addition to hard failures. Mechanical relays can experience chatter, for example. Computer hard disk drives may lock up, thereby requiring a re-boot.¹

Ideally, the engineer performs field tests whereby accelerometer measurements are made as a sample unit is exposed to a variety of shock events. "Tailored" test levels can then be derived from the field data. Safety margin can be added to account for unanticipated shock events.

Nevertheless, a generic shock specification is needed as a starting reference. The purpose of this report is to recommend a shock response spectrum specification for testing commercial products. The objective of the test method is to verify the design integrity of the product. The test is intended as a qualification test to be performed on one or two sample units. The recommended shock response spectrum test should supplement other shock test methods, as well as vibration test methods.

Product Example

Consider a cellular phone as an example of commercial product.

A hypothetical case history begins in the factory. The phone is resting on an assembly bench. A worker inadvertently knocks the phone off the bench. It strikes the floor.

Next, the phone is placed in a shipping container which is loaded onto a truck. The driver then runs over a set of railroad tracks at an imprudent speed.

A worker unloads the truck at the receiving dock of a retail store. The package slips from the workers hands and strikes a cement floor.

A customer purchases the phone. The customer places the phone on the passenger seat of his or her automobile. Another auto collides with the customer's vehicle. The phone strikes the inside surface of the passenger door.

Neither driver is seriously injured. The phone has now received a series of abusive shock pulses. Will the phone still function so that the customer can call for help?

The engineers at the cellular phone company must design the phone to withstand anticipated shock pulses. Tests may be used as part of the design process. Final qualification tests are also needed to verify the design integrity.

¹ The author experienced this problem when he used a notebook personal computer to monitor vehicle shock and vibration as the vehicle drove on a washboard road.

Test Plan

A thorough test plan should consist of at least two shock testing methods. Candidate methods are:

1. Drop shock
2. Classical pulse base input
3. Shock response spectrum

The first two methods are discussed briefly in Appendix A. The shock response spectrum method is given in the remainder of the main text.

Shock Response Spectrum Model

The shock response spectrum is a calculated function based on the acceleration time history. It applies an acceleration time history as a base excitation to an array of single-degree-of-freedom (SDOF) systems, as shown in Figure 1. Note that each system is assumed to have no mass-loading effect on the base input.

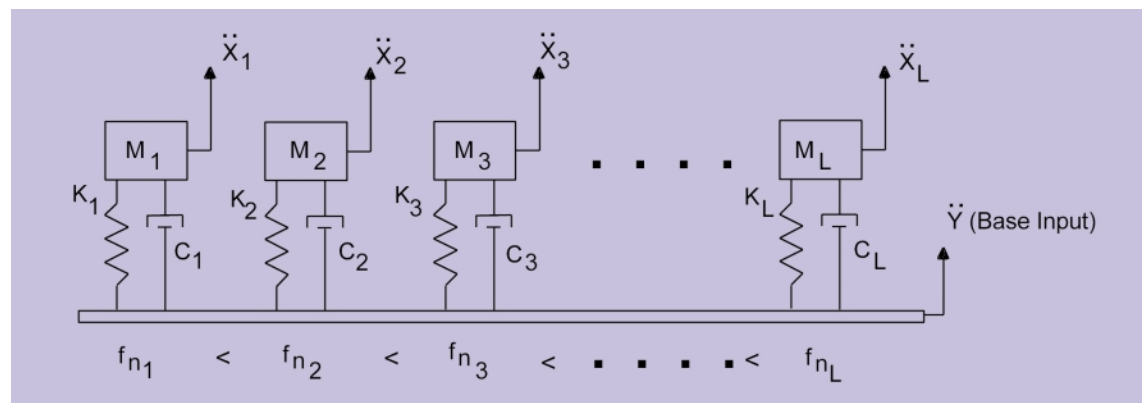

Figure 1. Shock Response Spectrum Model

\ddot{Y} is the common base input for each system, and \ddot{X}_i is the absolute response of each system to the input. The double-dot denotes acceleration. M_i is the mass, C_i is the damping coefficient, and K_i is the stiffness from each system. f_{n_i} is the natural frequency for each system.

The damping of each system is typically assumed as 5%, which is equivalent to $Q=10$. The natural frequency is an independent variable. Thus, the calculations performed for a number of independent SDOF systems, each with a unique natural frequency.

Any arbitrary set of unique natural frequencies can be used for the shock response spectrum calculation. A typical scheme, however, is based on a proportional bandwidth, such as 1/6 octave.

Base input example

Each SDOF system has a unique time history response to a given base input. An example is shown in Figure 2. Note that the response calculation is carried out via a convolution integral, as explained in References 1 and 2.

The shock response spectrum is the peak absolute acceleration response of each SDOF system to the time history base input. As an alternative, this function can be represented in terms of its peak positive and peak negative responses. The dimensions are peak response (G) versus natural frequency (Hz). Figure 3 shows the shock response spectrum corresponding to the example in Figure 2.4

MECHANICAL



Technology Training that Works

Contact IDC

<http://www.idc-online.com>

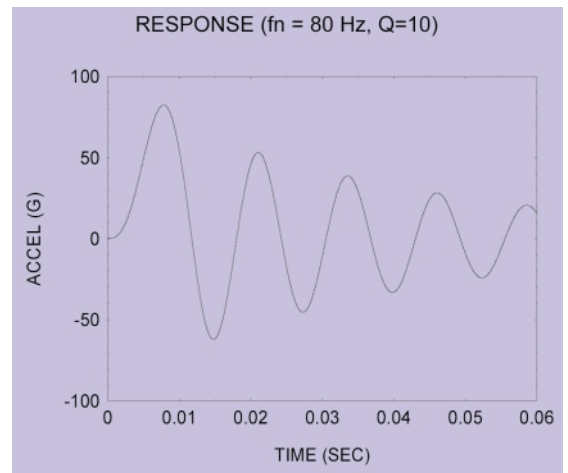
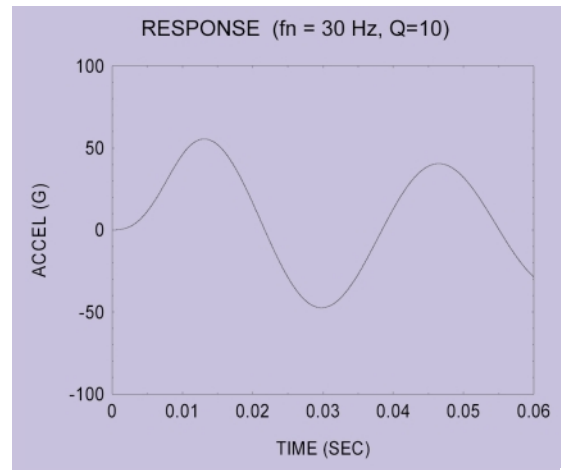
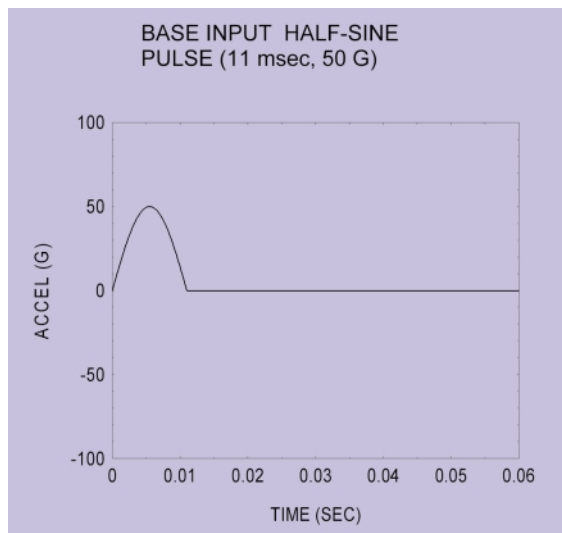

CONVOLUTION INTEGRAL

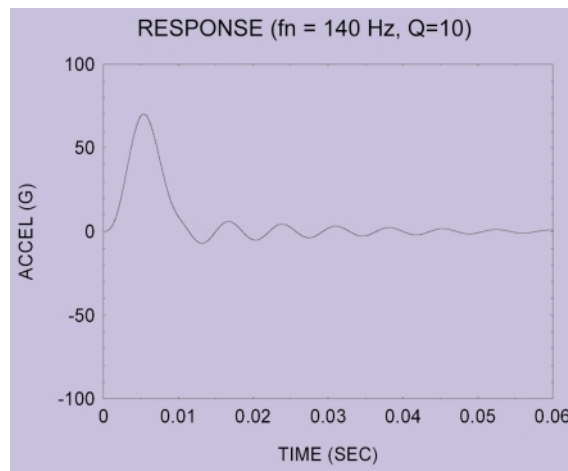

Figure 2. SDOF Response to Half-sine Base Input.

SHOCK RESPONSE SPECTRUM Q=10 BASE INPUT: HALF-SINE PULSE (11 msec, 50

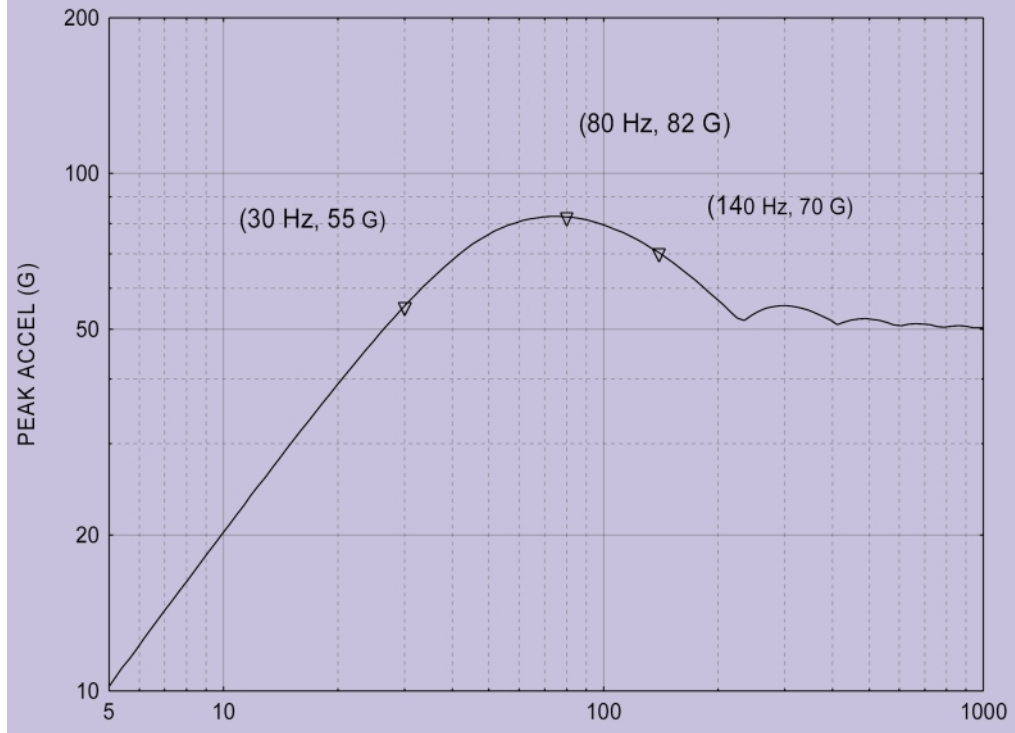

Figure 3. Corresponding Shock Response Spectrum

Note that coordinate pairs are given explicitly for three natural frequency cases. Each of these coordinates represents the peak absolute response for one of the examples in Figure 2.

Derivation

Newton's law can be applied to a free-body diagram of an individual system, as shown in Figure 4.

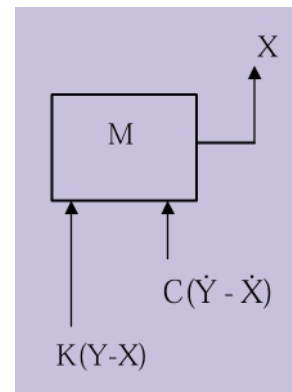

Figure 4. Free-body Diagram

A summation of forces yields the following governing differential equation of motion:

$$M\ddot{X} + C\dot{X} + KX = C\dot{Y} + KY \quad (1)$$

A relative displacement can be defined as $Z = X - Y$. The following equation is obtained by substituting this expression into equation (1):

$$M\ddot{Z} + C\dot{Z} + KZ = -M\ddot{Y} \quad (2)$$

Additional substitutions can be made as follows:

$$\omega_n^2 = \frac{K}{M} \quad (3)$$

$$2\varepsilon\omega_n = \frac{C}{M} \quad (4)$$

Note that ε is the damping ratio, and that ω_n is the natural frequency in radians per second. Furthermore, ε is often represented by the amplification factor Q , where $Q=1/(2\varepsilon)$.

Substitution of these terms into equation (2) yields an equation of motion for the relative response:

$$\ddot{Z} + 2\varepsilon\omega_n\dot{Z} + \omega_n^2 Z = -\ddot{Y}(t) \quad (5)$$

Equation (5) does not have a closed-form solution for the general case in which $Y(t)$ is an arbitrary function. A convolution integral approach must be used to solve the equation. Further details are given in References 1 and 2.

Recommended Specification

MIL-STD-810E, Method 516.4 outlines a variety of shock test specifications. A particular specification of interest is the Crash Hazard for Ground Equipment. This level is shown in Figure 5. Further application details are given in the figure caption.

A sample acceleration time history, which fulfills the level, is given in Figure 6. The time history can be applied as a base input to the test item using an electromagnetic shaker. A control computer is required to apply the time history to the shaker. The test item is mounted to the shaker via a fixture.

The time history was synthesized from wavelets as shown in Appendix B. The synthesis was performed on a personal computer using a trial-and-error approach. The corresponding shock response spectrum is given in Figure 7.

The time history in Figure 5 is 400 milliseconds long.

MIL-STD-810E recommends a duration of 3.5 to 5 milliseconds based on a terminal sawtooth pulse. Nevertheless, MIL-STD-810E allows for longer duration pulses.

A longer pulse can accommodate oscillations. A properly designed oscillating pulse has the advantage of producing symmetric positive and negative peak responses. Positive and negative requirements for a given axis can thus be met using a single oscillating pulse. On the other hand, a sawtooth pulse would need to be applied in each direction of each axis.

Conclusion

The shock response spectrum level in Figure 5 is recommended for commercial products. Again, this test can be performed on an electromagnetic shaker with a suitable control computer.

The advantage of the shock response spectrum method is that it allows for excitation of a wide range of possible natural frequencies along with uniform response amplitude across those frequencies. Prior knowledge of an item's natural frequency is useful but not required.

Again, additional shock test methods should be performed as part of a comprehensive test program. Vibration tests should also be included.

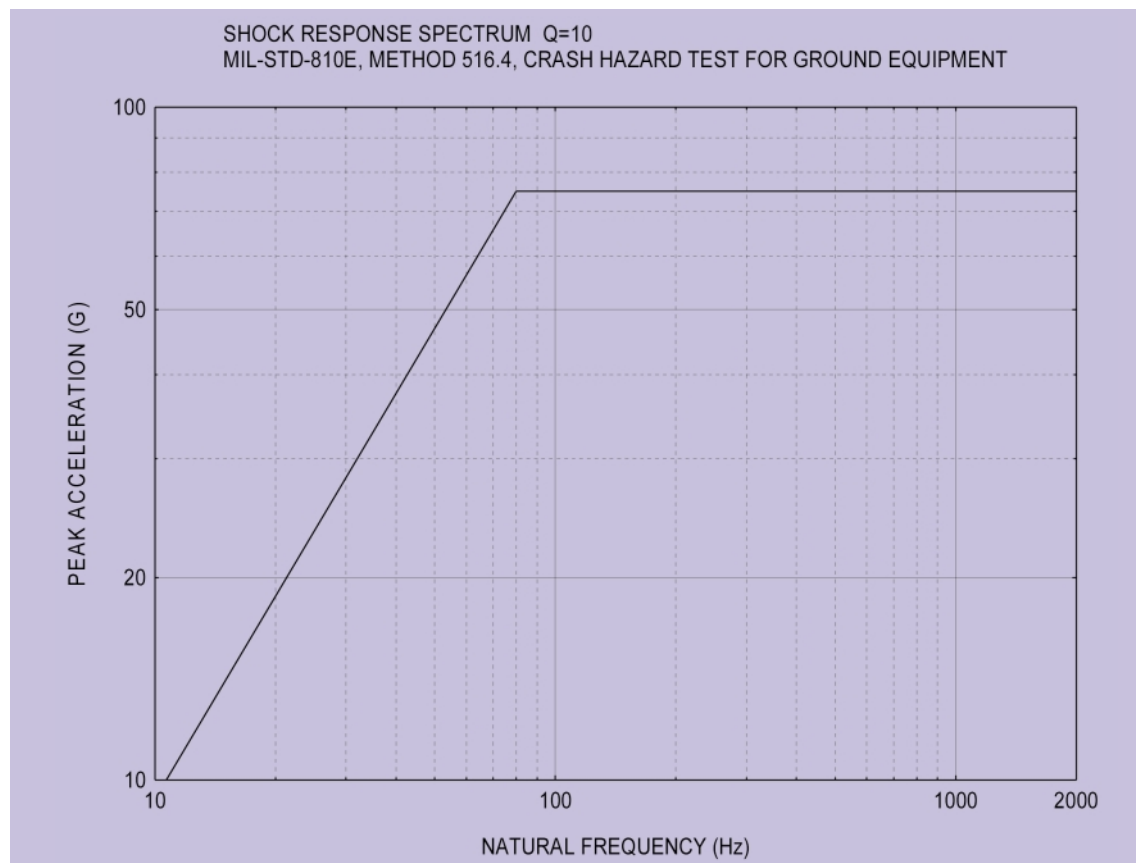

Figure 5. Shock Response Specification

The frequency spacing should be 1/6 octave. Both positive and negative spectra must fulfill the specified level within ± 3 dB tolerance bands. The shock pulse should be applied three times in each of three orthogonal axes. The breakpoints are given in Table 1.

Table 1. SRS Q=10	
Natural Frequency (Hz)	Peak Acceleration (G)
10	9.4
80	75
2000	75

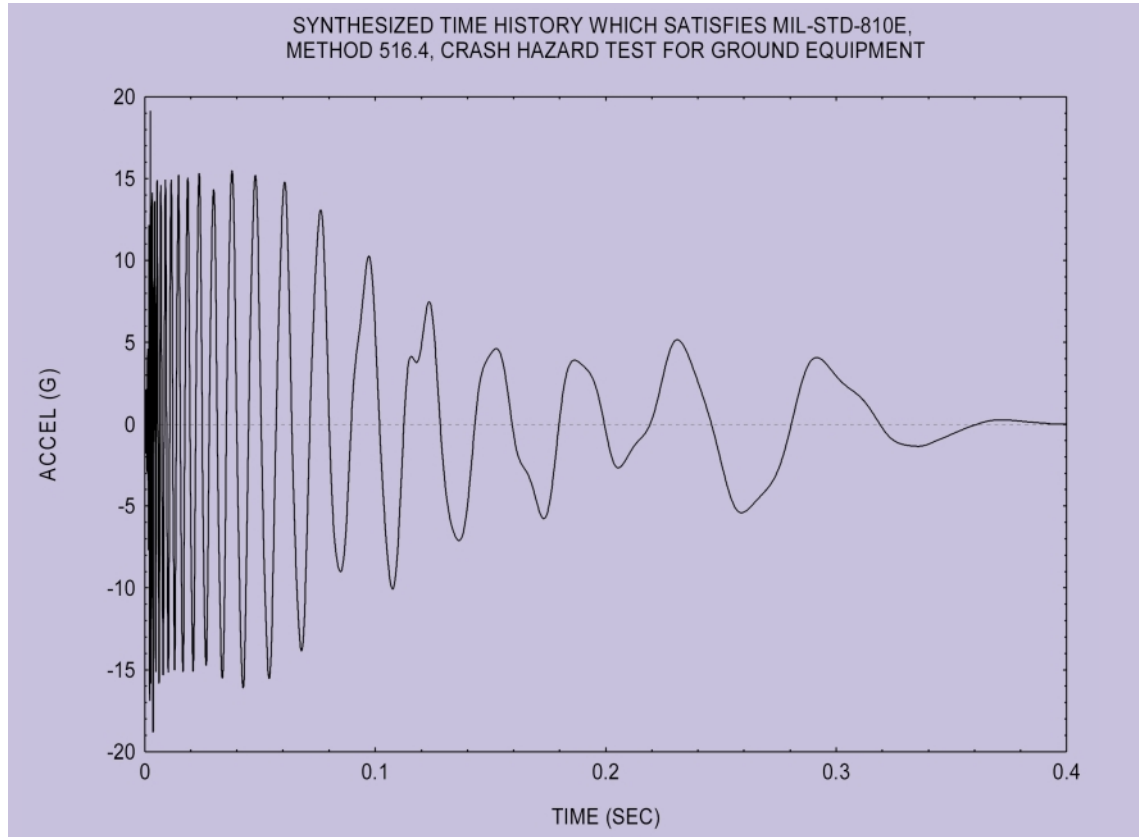

Figure 6. Synthesized Base Input Time History

The time history is a summation of wavelets. A corresponding wavelet table is given in Appendix B. The synthesis process is an iterative, trial-and-error method. There is no simple formula for this task. Also note that a given shock response spectrum does not have a unique corresponding time history.

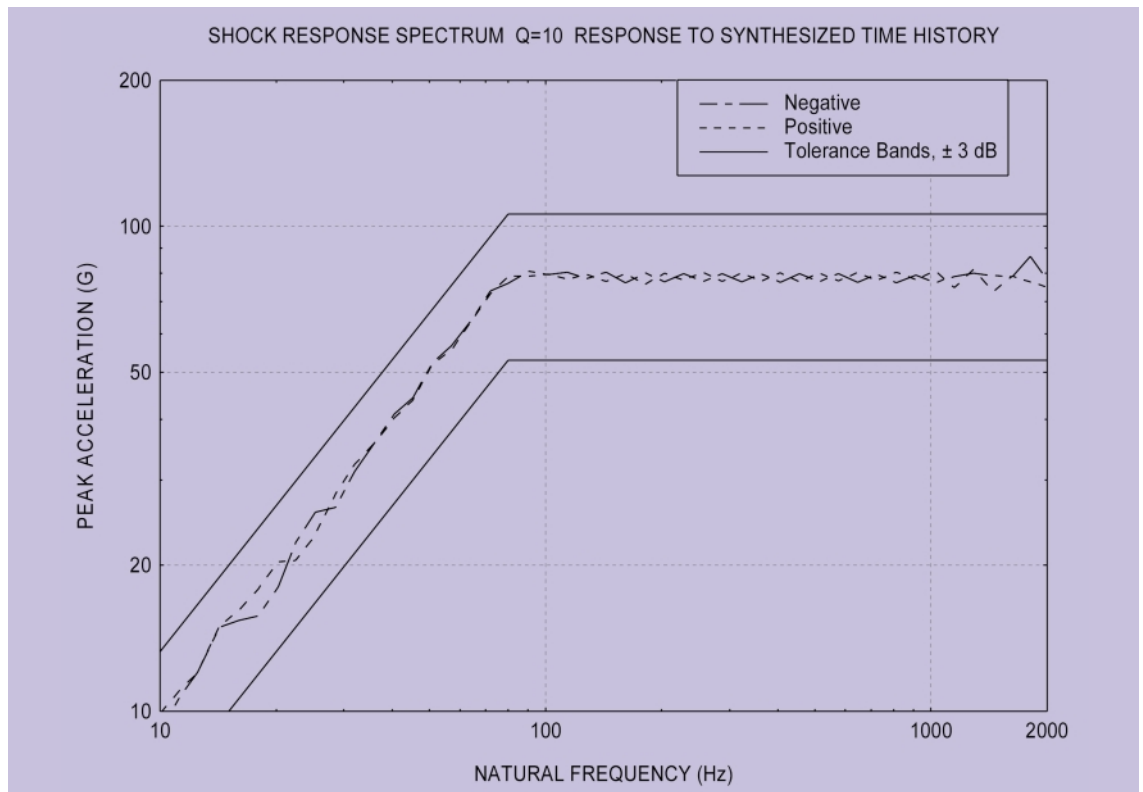

Figure 7. Shock Response Spectrum from Synthesized Base Input Time History

References

1. W. Thomson, Theory of Vibration with Applications, Second Edition, Prentice-Hall, New Jersey, 1981
2. T. Irvine, An Introduction to the Shock Response Spectrum, Vibration data.com Publications, 1998.
3. C. Harris, Shock and Vibration Handbook 4 th ed., McGraw-Hill, New York, 1996.

APPENDIX A

ADDITIONAL SHOCK TEST METHODS

Drop Shock

A drop shock is a free-fall shock. The test item is released from a resting position at some predetermined height. A fixture may be used to control whether a face, edge, or corner strikes the ground first. The advantage of the drop shock method is that it is fairly simple to perform. It also is a very realistic simulation of certain shock events which an item may encounter.

Further information about the drop shock method is given in References 1 and 3.

Classical Base Input

The half sine pulse in Figure 2 is an example of a classical base input pulse. A terminal sawtooth is another example. Typical classical pulses have a uniform direction with no oscillation. A classical pulse can be applied to a test item using either an electromagnetic shaker or a drop table.

A classical pulse is sometimes referred to as a velocity shock because the velocity change is equal to the area under the acceleration pulse.

Performance of a classical pulse on a shaker requires certain precautions. Note that a shaker must have zero net velocity and zero net displacement. Compensation pulses must be used before and after the classical pulse to meet these conditions. The compensation pulses typically have peak amplitudes less than 20% of the classical pulse.

Further information about classical pulses is given in References 2 and 3.



Technology Training that Works

Contact IDC

<http://www.idc-online.com>

APPENDIX B

WAVELET METHOD

A shock response spectrum can be met using a series of wavelets. The wavelets are synthesized into a time history on a control computer. The control computer applies the time history to an electromagnetic shaker. The shaker then applies the shock pulse to the test item. The control computer then verifies the resulting shock pulse.

$$W_m(t) = \begin{cases} 0, & \text{for } t < t_{dm} \\ A_m \sin\left[\frac{2\pi f_m}{N_m}(t - t_{dm})\right] \sin[2\pi f_m(t - t_{dm})], & \text{for } t_{dm} \leq t \leq \left[t_{dm} + \frac{N_m}{2f_m}\right] \\ 0, & \text{for } \left[t_{dm} + \frac{N_m}{2f_m}\right] < t \end{cases}$$

The equation for an individual wavelet is:

where $W_m(t)$ is the acceleration of wavelet m at time t ,
 A_m is the wavelet acceleration amplitude,
 f_m is the wavelet frequency,
 N_m is the number of half-sines in the wavelet,
 t_{dm} is the wavelet time delay.

Note that N_m must be an odd integer and must be at least 3.

The total acceleration at any time t for a set of n wavelets is

$$\ddot{x}(t) = \sum_{m=1}^n W_m(t)$$

Selection of the proper wavelet parameters to fulfill a given shock response spectrum is a trial-and-error process. Prior experience is a valuable guideline. Note that the wavelet is designed to have zero net velocity and zero net displacement.



Technology Training that Works

Contact IDC

<http://www.idc-online.com>



Table B-1. Wavelet Parameters			
Frequency (Hz)	Amplitude (G)	Half-sines	Delay (msec)
10.0	-1.3	7	29.88
11.3	1.1	9	0.00
12.5	-1.7	9	11.77
14.3	0.9	9	67.62
16.0	-1.0	9	63.55
18.0	1.0	11	59.13
20.2	-0.9	11	55.20
22.5	1.0	13	51.03
25.2	-1.1	15	46.73
28.5	1.8	17	42.42
32.0	-2.0	19	38.13
36.0	2.4	21	33.91
40.5	-2.3	21	30.16
45.3	3.0	21	26.81
50.8	-2.7	21	23.81
57.0	4.1	21	21.15
64.0	-3.8	21	18.78
72.0	3.8	21	16.67
80.0	-5.7	21	14.77
90.5	4.7	21	13.09
101.6	-4.7	21	11.60
114.0	4.3	21	10.27
128.0	-4.6	21	9.08
143.7	4.3	21	8.03
161.3	-4.4	21	7.09
181.0	4.4	21	6.25
203.2	-4.6	21	5.50
228.1	4.6	21	4.83
256.0	-4.4	21	4.24
287.4	4.5	21	3.71
322.5	-4.5	21	3.24
362.0	4.5	21	2.82
406.4	-4.4	21	2.45
456.1	4.5	21	2.12
512.0	-4.5	21	1.82
574.7	4.5	21	1.55
645.1	-4.4	21	1.32
724.1	4.5	21	1.11
812.7	-4.4	21	0.92
912.3	4.6	21	0.76
1024	-4.3	21	0.61
1149	4.7	21	0.48
1290	-4.0	21	0.36
1448	5.2	21	0.25
1625	-3.9	21	0.16
1810	2.4	21	0.08
2000	-6.3	21	0.00

Table B-1 gives the wavelets corresponding to the time history in Figure 6.