

VIBRATIONAL ANALYSIS OF QUARTER CAR VEHICLE DYNAMIC SYSTEM SUBJECTED TO HARMONIC EXCITATION BY ROAD SURFACE

S. H. SAWANT¹, MRUNALINEE V. BELWALKAR², MANORAMA A. KAMBLE³, PUSHPA B. KHOT⁴ & DIPALI D. PATIL⁵

^{1,2,3,4&5}Mechanical Engineering Department, Dr. J. J. Magdum College of Engineering, Jaysingpur
E-mail : sanjaysawant2010@gmail.com

Abstract - A front suspension of Hyundai Elantra 1992 model is assigned as quarter car model and is considered for the performance study. Modeling the dynamic performance of an automobile car system represents a complex task and forms an important step in its design procedure. In this paper the stationary response of quarter car vehicle model moving with a constant velocity over a rough road is considered for the performance study. For this a simplified model and experimental set up is developed. The deterministic impulses due to road profile are given by an eccentric cam which gives input motion to front suspension acting as a follower of the cam. The displacements obtained by FFT analyzer at upper mount of shock absorber were compared with the analytical and MATLAB results.

Keywords - Deterministic, Hyundai Elantra 1992 front suspension, , MATLAB simulink, Quarter car model, Road profile, Stationary response.

I. INTRODUCTION

The vehicle theoretical studies require accurate representation of tire behavior and road surface irregularities. One of the important factor in the subject of vehicle design is the suspension system studies.[1]

The health and safety risks associated with prolonged exposure to high vehicle vibrations have prompted a demand for enhancement of ride quality performance of vehicle. Vehicle drivers are exposed to ride vibration for 8 to 10 hrs a day. In view of driver's health and safety risk associated with prolonged exposure to high levels of ride vibrations and significant dynamic tire forces resulting in accelerated suspensions needs to be further investigated for use in vehicles. Because of this it involves a careful compromise among the various conflicting and directional control performance, suspension deflections and tire forces.[2]

Suspension is subjected to various road conditions like a single step road profile, brake and release maneuver, sinusoidal road profile with pitching, heaving and mixed model excitation, broad band road profile etc. at constant or variable speed[3]. The measurement of road surface qualities is one of the important opportunities of vehicle manufactures all over the world. The operations of the measuring devices depend mainly on the use of displacement transducers [4].

In this paper quarter car vehicle model is developed for analysis of vibrational effect when it is subjected to harmonic excitation by road profile. For this analysis experimental setup for Hyundai Elantra

1992 front suspension is developed and harmonic road excitations are given to this with eccentric cam and displacement results are obtained with FFT analyzer. These results are compared with analytical and MATLAB Simulink results.

II. ROAD PROFILE AND WHEEL TRAVEL:

Road is considered as an infinite cam with wavy profile of harmonic waves and wheel of quarter car model is considered as follower. As the road is considered as cam which will give harmonic road excitation to suspension system, in this paper an eccentric cam is used as exciter for suspension system. The road profile is approximated by a sine wave represented by $q=Y \sin \omega t$ as shown in Fig.1

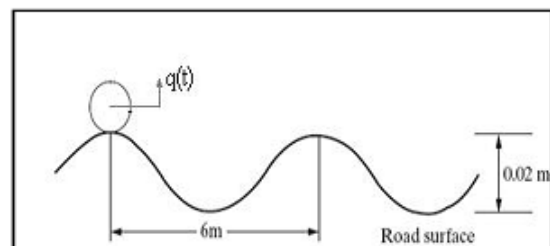

Fig.1: Road profile represented by sine wave.

Where,

q = Road surface excitation at time t in m.

Y = Amplitude of sine wave = 0.01 m. and

l = Wavelength of road surface = 6 m.

For the above data and velocity of the vehicle in Km/h, the excitation frequency (ω) is given by,

$$\omega = v \left(\frac{1}{0.006} \right) \left(\frac{1}{3600} \right) (2\pi) = 0.2909 v \text{ rad/sec.}$$

The natural frequency of the vehicle dynamic system is given by,

$$\omega_n = \sqrt{\frac{K}{M}}$$

Where,

K = Stiffness of spring (N/m) and,
M = Sprung mass (Kg)

The values of K, M and damping coefficient (c) were obtained from the experimental data [5].

These values are K=12394 N/m., M = 236.124 Kg., and c = 1385.4Nsec/m

$$\therefore \omega_n = 7.245 \text{ rad/sec}$$

Similarly, damping ratio (ζ) for the front suspension is calculated by the equation

$$\zeta = \frac{c}{2\sqrt{kM}} = 0.404$$

III. EXPERIMENTAL SETUP

To understand the actual behavior of suspension system when it is subjected to harmonic motion provided by road surface, the experimental setup is developed.

Fig. 2 shows the experimental setup.

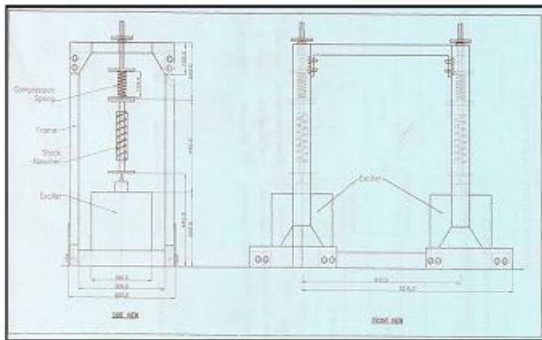

Fig. 2 : Experimental setup.

It consists of shock absorber attached to a compression spring. The load equal to sprung weight is applied by tightening nut on it. An eccentric cam is used to provide excitation is placed at the bottom of shock absorber, which is connected to shaft of an electric motor. The displacement of shock absorber due to cam rotation is measured by FFT analyzer by mounting accelerometer at upper mount of shock absorber.

IV. MODELING OF THE SYSTEM

For Hyundai Elantra 1992 front suspension, quarter car model is as shown in Fig.3

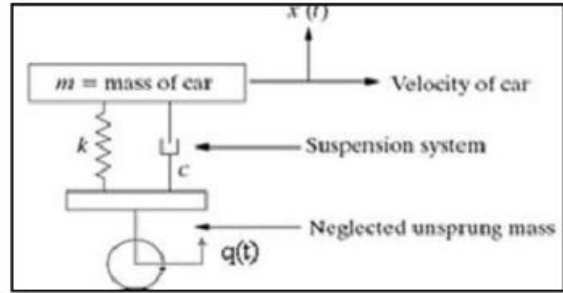

Fig. 3: Quarter car model for Hyundai Elantra 1992 front suspension

The equation of motion for this model is,

The MATLAB simulink model for the same is prepared as shown in Fig. 4 and the sprung mass displacement for different excitation frequencies were obtained in time domain. This displacement for excitation frequency equal to natural frequency of vehicle dynamic system is as shown is Fig.5, from these results values of amplitude response (X) were obtained.

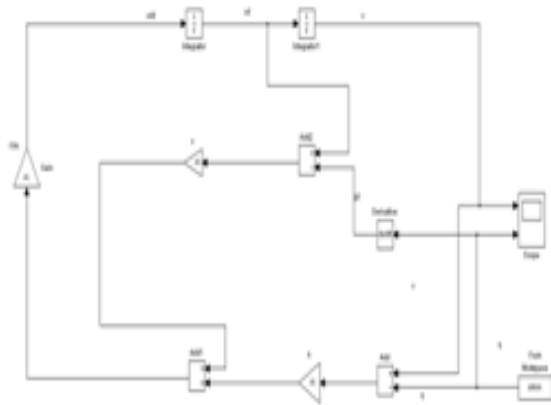

Fig. 4 : MATLAB simulink model for quarter car vehicle dynamic system

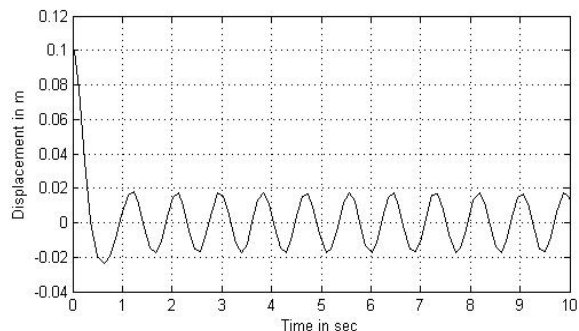

Fig. 5 : Sprung mass displacement for excitation frequency equal to natural frequency

V. THEORETICAL ANALYSIS:

The excitation frequencies (ω) were calculated for different car velocities, and corresponding to these

frequencies amplitude of the response (X) is calculated by the equation

$$X=Y\sqrt{\frac{1+(2\zeta r)^2}{(1-r^2)^2+(2\zeta r)^2}}$$

Where r = frequency ratio = —

VI. EXPERIMENTAL ANALYSIS:

The excitation to shock absorber is given with eccentric cam and the results in frequency domain are obtained on FFT Analyzer by mounting accelerometer at upper mount of the shock absorber. The result is as shown in Fig.6

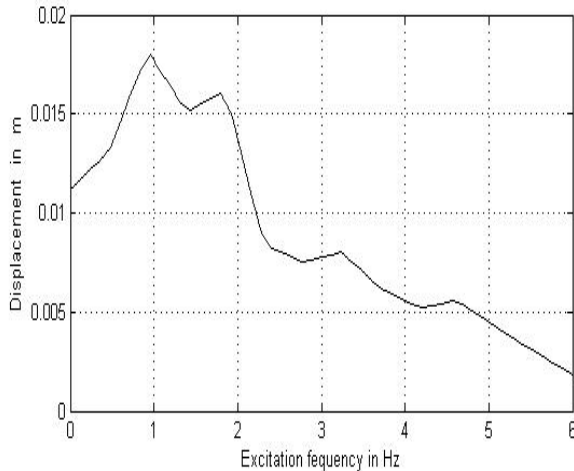

Fig. 6: Frequency response (sprung mass displacement) for different excitation frequencies obtained with FFT Analyzer.

VII.RESULTS AND DISCUSSIONS

The theoretical, MATLAB simulink and experimental values for different excitation frequencies were tabulated as shown in Table 1.

Table 1: The theoretical, MATLAB simulink and experimental values for different excitation frequencies

Excitation Frequency (f) Hz	Amplitude (X) m [By Theoretical Method]	Amplitude (X) m [By MATLAB Simulink]	Amplitude (X) m [By Experimental Method]
0	0.01	0.01	0.0112
0.4629	0.0116	0.0119	0.0131
0.9258	0.0161	0.0163	0.0182
1.1528	0.0159	0.0168	0.0171
1.3887	0.013	0.0129	0.0151
1.8516	0.0080100	0.00824	0.0162
2.3146	0.0055493	0.00549	0.00842
2.7775	0.0042275	0.004202	0.00751
3.2407	0.0034207	0.003375	0.00801
3.7033	0.0028801	0.0029	0.0062

4.1662	0.0024914	0.00248	0.00523
4.6291	0.0021988	0.00221	0.00559
5.0920	0.0019697	0.00193	0.00419
5.5550	0.0017855	0.001687	0.00298

The graphs for theoretical method and MATLAB simulink model were plotted as shown in Fig.7.

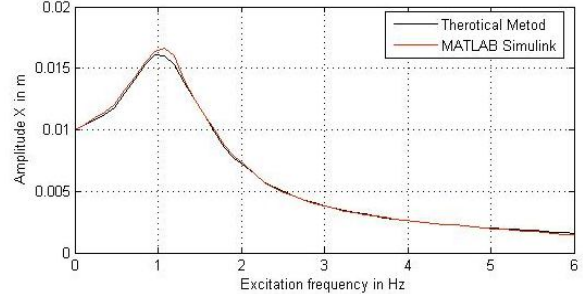

Fig. 7 : Frequency response (sprung mass displacement) for different excitation frequencies by therotical and MATLAB Simulink model.

From these graphs it is observed that these values are very close to each other but if these results are compared with the experimental results, the values of X obtained experimentally are large as compared to theoretical and MATLAB simulink results.

VIII. CONCLUSION:

From the results and discussions it is concluded that there is very less difference between theoretical and MATLAB simulink results, and which may be due to truncation. But there is large difference between experimental and theoretical or Experimental and MATLAB simulink results, which may be due to non linearities in suspension parameters. Therefore it is very much essential to consider the nonlinearities in suspension parameters at the time of modeling of vehicle dynamic system for its vibration analysis.

REFERENCES:

- [1] Samy aly Hassan, Omar Shawkat Lashine, "Identification of road urface qualities for linear and non-linear vehicle modeling", IMAC-XX-Conf-S11P07
- [2] Faisal Queslati, Subhash Rakheja, Seshadri Sankar, "study of an active suspension for improved ride quality and reduced dynamic wheel loads", Road transport technology4, University of Michigan Transportation research institute, Ahn, arbour 1995
- [3] Satish B. Purohit, S.R. Lapalikar, Vikas Jain , "Effect of road profile and curves generated by wheel on the performance of a shock absorber of a motorcycle", Indian journal of science and technology, vol4 No.5 (2011)
- [4] Hans Perm, A Laser-based highway-speed road profile measuring system, 10th. IAVSD (1987)
- [5] C. Kim, P. I. Ro, A sliding mode controller for vehicle active suspension systems with non linerities, Proc. Instn. Mech. Engrs, Vol. 1212, Part D, (1998), pp 79-92.