

Thick cylinders- Stresses due to internal and external pressures.

Instructional Objectives:

At the end of this lesson, the students should have the knowledge of:

- Stresses in thick cylinders.
- Lamé's equation for radial and circumferential stresses.
- Distribution of radial and circumferential stresses for different boundary conditions.
- Methods of increasing elastic strength of thick cylinders by prestressing.

9.2.1 Stresses in thick cylinders

For thick cylinders such as guns, pipes to hydraulic presses, high pressure hydraulic pipes the wall thickness is relatively large and the stress variation across the thickness is also significant. In this situation the approach made in the previous section is not suitable. The problem may be solved by considering an axisymmetry about z-axis and solving the differential equations of stress equilibrium in polar co-ordinates. In general the stress equations of equilibrium without body forces can be given as

$$\begin{aligned}\frac{\partial \sigma_r}{\partial r} + \frac{1}{r} \frac{\partial \tau_{r\theta}}{\partial \theta} + \frac{\partial \tau_{rz}}{\partial z} + \frac{\sigma_r - \sigma_\theta}{r} &= 0 \\ \frac{\partial \tau_{\theta r}}{\partial r} + \frac{1}{r} \frac{\partial \tau_\theta}{\partial \theta} + \frac{\partial \tau_{\theta z}}{\partial z} + 2 \frac{\tau_{\theta r}}{r} &= 0 \\ \frac{\partial \tau_{zr}}{\partial r} + \frac{1}{r} \frac{\partial \tau_{z\theta}}{\partial \theta} + \frac{\partial \sigma_z}{\partial z} + \frac{\tau_{zr}}{r} &= 0\end{aligned}\tag{1}$$

For axisymmetry about z-axis $\frac{\partial}{\partial \theta} = 0$ and this gives

$$\begin{aligned}\frac{\partial \sigma_r}{\partial r} + \frac{\partial \tau_{rz}}{\partial z} + \frac{\sigma_r - \sigma_\theta}{r} &= 0 \\ \frac{\partial \tau_{\theta r}}{\partial r} + \frac{\partial \tau_{\theta z}}{\partial z} + 2 \frac{\tau_{\theta r}}{r} &= 0 \\ \frac{\partial \tau_{zr}}{\partial r} + \frac{\partial \sigma_z}{\partial z} + \frac{\tau_{zr}}{r} &= 0\end{aligned}\tag{2}$$

In a plane stress situation if the cylinder ends are free to expand $\sigma_z = 0$ and due to uniform radial deformation and symmetry $\tau_{rz} = \tau_{\theta z} = \tau_{r\theta} = 0$. The equation of equilibrium reduces to

$$\frac{\partial \sigma_r}{\partial r} + \frac{\sigma_r - \sigma_\theta}{r} = 0$$

This can be written in the following form:

$$r \frac{\partial \sigma_r}{\partial r} + \sigma_r = \sigma_\theta \quad (3)$$

If we consider a general case with body forces such as centrifugal forces in the case of a rotating cylinder or disc then the equations reduce to

$$\frac{\partial \sigma_r}{\partial r} + \frac{\sigma_r - \sigma_\theta}{r} + \rho \omega^2 r = 0 \quad \text{which may be written as}$$

$$r \frac{\partial \sigma_r}{\partial r} - \sigma_\theta + \sigma_r + \rho \omega^2 r^2 = 0 \quad (4)$$

It is convenient to solve the general equation so that a variety of problems may be solved.

Now as shown in **figure- 9.2.1.1**, the strains ϵ_r and ϵ_θ may be given by

$$\epsilon_r = \frac{\partial u_r}{\partial r} = \frac{1}{E} [\sigma_r - \nu \sigma_\theta] \quad \text{since } \sigma_z = 0 \quad (5)$$

$$\epsilon_\theta = \frac{(r + u_r) \Delta \theta - r \Delta \theta}{r \Delta \theta} = \frac{u_r}{r} = \frac{1}{E} [\sigma_\theta - \nu \sigma_r] \quad (6)$$

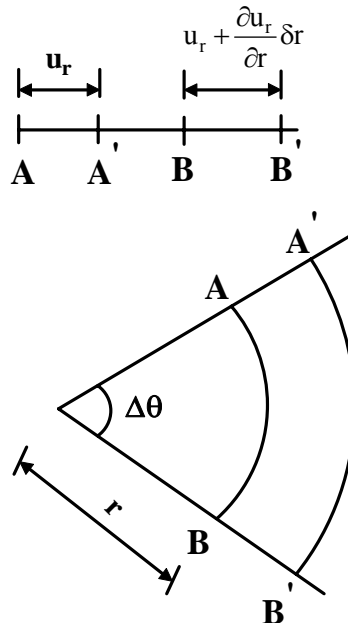

9.2.1.1F- Representation of radial and circumferential strain.

Combining equation (5) and (6) we have

$$r \frac{\partial \sigma_{\theta}}{\partial r} - \nu r \frac{\partial \sigma_r}{\partial r} + (1 + \nu)(\sigma_{\theta} - \sigma_r) = 0 \quad (7)$$

Now from equation (4) we may write

$$\frac{\partial \sigma_{\theta}}{\partial r} = r \frac{\partial^2 \sigma_r}{\partial r^2} + 2 \frac{\partial \sigma_r}{\partial r} + 2\rho\omega^2 r \quad \text{and combining this with equation (7) we}$$

may arrive at

$$r \frac{\partial^2 \sigma_r}{\partial r^2} + 3 \frac{\partial \sigma_r}{\partial r} + (3 + \nu)\rho\omega^2 r = 0 \quad (8)$$

For a non-rotating thick cylinder with internal and external pressures p_i and p_o we substitute $\omega = 0$ in equation (8) and this gives

$$r \frac{\partial^2 \sigma_r}{\partial r^2} + 3 \frac{\partial \sigma_r}{\partial r} = 0 \quad (9)$$

A typical case is shown in **figure- 9.2.1.2**. A standard solution for equation (9) is $\sigma_r = c r^n$ where c and n are constants. Substituting this in equation (9) and also combining with equation (3) we have

$$\begin{aligned} \sigma_r &= c_1 + \frac{c_2}{r^2} \\ \sigma_{\theta} &= c_1 - \frac{c_2}{r^2} \end{aligned} \quad (10)$$

where c_1 and c_2 are constants.

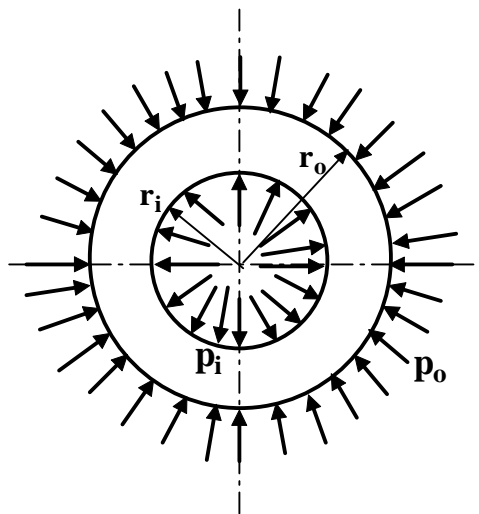

9.2.1.2F- A thick cylinder with both external and internal pressure.

Boundary conditions for a thick cylinder with internal and external pressures p_i and p_o respectively are:

$$\text{at } r = r_i \quad \sigma_r = -p_i$$

$$\text{and at } r = r_o \quad \sigma_r = -p_o$$

The negative signs appear due to the compressive nature of the pressures. This gives

$$c_1 = \frac{p_i r_i^2 - p_o r_o^2}{r_o^2 - r_i^2} \quad c_2 = \frac{r_i^2 r_o^2 (p_o - p_i)}{r_o^2 - r_i^2}$$

The radial stress σ_r and circumferential stress σ_θ are now given by

$$\begin{aligned} \sigma_r &= \frac{p_i r_i^2 - p_o r_o^2}{r_o^2 - r_i^2} + \frac{r_i^2 r_o^2 (p_o - p_i)}{r_o^2 - r_i^2} \frac{1}{r^2} \\ \sigma_\theta &= \frac{p_i r_i^2 - p_o r_o^2}{r_o^2 - r_i^2} - \frac{r_i^2 r_o^2 (p_o - p_i)}{r_o^2 - r_i^2} \frac{1}{r^2} \end{aligned} \quad (11)$$

It is important to remember that if σ_θ works out to be positive, it is tensile and if it is negative, it is compressive whereas σ_r is always compressive irrespective of its sign.

Stress distributions for different conditions may be obtained by simply substituting the relevant values in equation (11). For example, if $p_o = 0$ i.e. there is no external pressure the radial and circumferential stress reduce to

$$\begin{aligned} \sigma_r &= \frac{p_i r_i^2}{r_o^2 - r_i^2} \left(-\frac{r_o^2}{r^2} + 1 \right) \\ \sigma_\theta &= \frac{p_i r_i^2}{r_o^2 - r_i^2} \left(\frac{r_o^2}{r^2} + 1 \right) \end{aligned} \quad (12)$$

The stress distribution within the cylinder wall is shown in **figure- 9.2.1.3**.

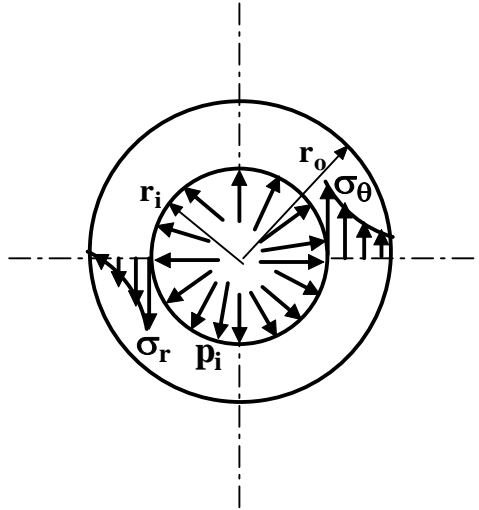

9.2.1.3F- Radial and circumferential stress distribution within the cylinder wall when only internal pressure acts.

It may be noted that $\sigma_r + \sigma_\theta = \text{constant}$ and hence the deformation in z-direction is uniform. This means that the cross-section perpendicular to the cylinder axis remains plane. Hence the deformation in an element cut out by two adjacent cross-sections does not interfere with the adjacent element. Therefore it is justified to assume a condition of plane stress for an element in section 9.2.1.

If $p_i = 0$ i.e. there is no internal pressure the stresses σ_r and σ_θ reduce to

$$\sigma_r = \frac{p_o r_o^2}{r_o^2 - r_i^2} \left(\frac{r_i^2}{r^2} - 1 \right)$$

$$\sigma_\theta = -\frac{p_o r_o^2}{r_o^2 - r_i^2} \left(\frac{r_i^2}{r^2} + 1 \right)$$
(13)

The stress distributions are shown in **figure-9.2.1.4**.

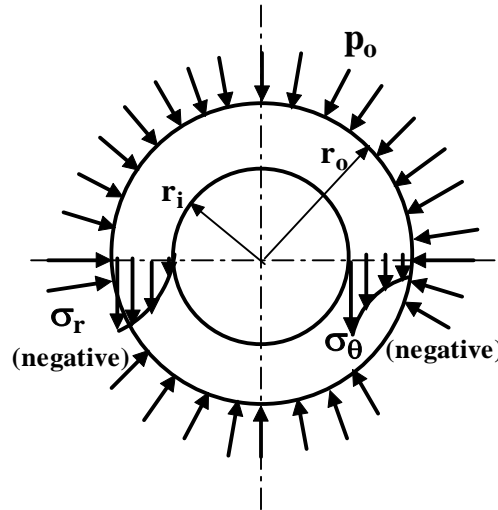

9.2.1.4F- Distribution of radial and circumferential stresses within the cylinder wall when only external pressure acts.

9.2.2 Methods of increasing the elastic strength of a thick cylinder by pre-stressing

In thick walled cylinders subjected to internal pressure only it can be seen from equation (12) that the maximum stresses occur at the inside radius and this can be given by

$$\sigma_{r(\max)} \Big|_{r=r_i} = -p_i \qquad \sigma_{\theta(\max)} \Big|_{r=r_i} = p_i \frac{\frac{r_o^2 + r_i^2}{2} - \frac{r_o^2 - r_i^2}{2}}{r_o^2 - r_i^2}$$

This means that as p_i increases σ_θ may exceed yield stress even when $p_i < \sigma_{\text{yield}}$. Furthermore, it can be shown that for large internal pressures in thick walled cylinders the wall thickness is required to be very large. This is shown schematically in **figure- 9.2.2.1**. This means that the material near the outer edge is not effectively used since the stresses near the outer edge gradually reduce (Refer to **figure- 9.2.1.3**).

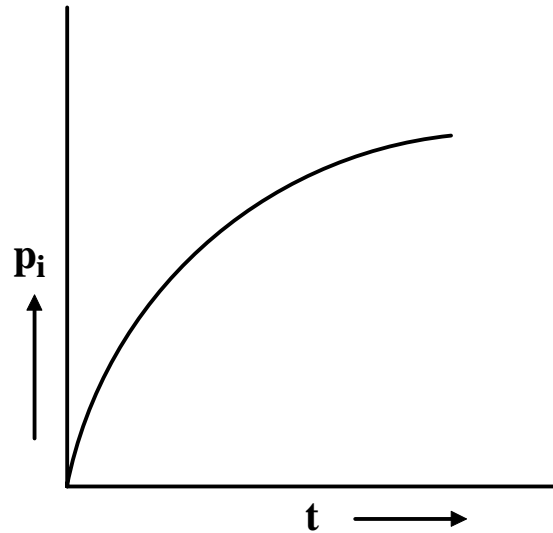

9.2.2.1F- A schematic variation of wall thickness with the internal pressure in a thick walled cylinder.

In order to make thick-walled cylinders that resist elastically large internal pressure and make effective use of material at the outer portion of the cylinder the following methods of pre-stressing are used:

1. Shrinking a hollow cylinder over the main cylinder.
2. Multilayered or laminated cylinders.
3. Autofrettage or self hooping.

1. Composite cylinders

An outer cylinder (jacket) with the internal diameter slightly smaller than the outer diameter of the main cylinder is heated and fitted onto the main cylinder. When the assembly cools down to room temperature a composite cylinder is obtained. In this process the main cylinder is subjected to an external pressure leading to a compressive radial stress at the interface. The outer cylinder or the jacket is subjected to an internal pressure leading to a tensile circumferential stress at the inner wall. Under this condition as the internal pressure increases the compression in the inner cylinder is first released and then only the cylinder begins to act in tension. Gun barrels

are normally pre-stressed by hooping since very large internal pressures are generated.

Here the main problem is to determine the contact pressure p_s . At the contact surface the outer radius r_{si} of the inner cylinder is slightly larger than the inside diameter r_{so} of the outer cylinder. However for stress calculations we assume that $r_{so} \approx r_{si} = r_s$ (say). The inner and outer cylinders are shown in **figure- 9.2.2.2**.

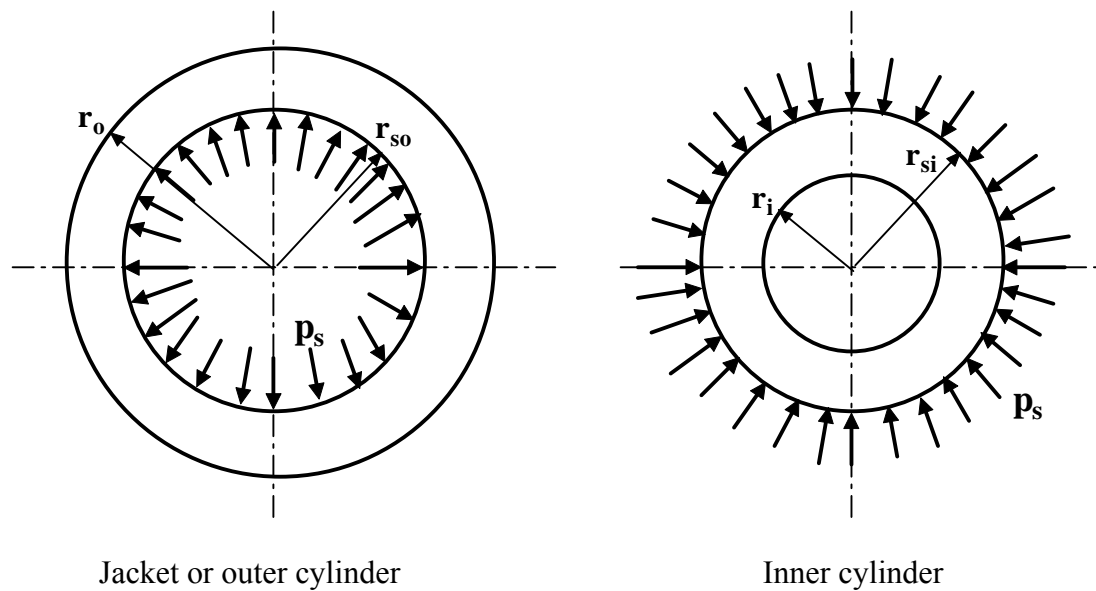

Jacket or outer cylinder

Inner cylinder

9.2.2.2F- Dimensions and the pressures at the contact surface of the internal and outer cylinders.

For the outer cylinder the radial and circumferential stresses at the contact surface may be given by

$$\sigma_r|_{r=r_s} = \frac{p_s r_s^2}{r_o^2 - r_s^2} \left(1 - \frac{r_o^2}{r_s^2} \right) = -p_s$$

$$\sigma_\theta|_{r=r_s} = \frac{p_s r_s^2}{r_o^2 - r_s^2} \left(1 + \frac{r_o^2}{r_s^2} \right)$$

In order to find the radial displacements of the cylinder walls at the contact we consider that $\varepsilon_\theta = \frac{u}{r} = \frac{1}{E}(\sigma_\theta - \nu\sigma_r)$. This gives the radial displacement of the inner wall of the outer cylinder as

$$u_{r1} = \frac{p_s r_s}{E} \left[\frac{r_o^2 + r_s^2}{r_o^2 - r_s^2} + \nu \right]$$

Similarly for the inner cylinder the radial and circumferential stresses at the outer wall can be given by

$$\sigma_r \Big|_{r=r_s} = -p_s$$

$$\sigma_\theta \Big|_{r=r_s} = -p_s \frac{r_s^2 + r_i^2}{r_s^2 - r_i^2}$$

And following the above procedure the radial displacement of the contact surface of the inner cylinder is given by

$$u_{r2} = -\frac{p_s r_s}{E} \left[\frac{r_s^2 + r_i^2}{r_s^2 - r_i^2} - \nu \right]$$

The total interference δ at the contact is therefore given by

$$\delta = \frac{p_s r_s}{E} \left[\frac{r_o^2 + r_s^2}{r_o^2 - r_s^2} + \frac{r_s^2 + r_i^2}{r_s^2 - r_i^2} \right]$$

This gives the contact pressure in terms of the known variables as follows:

$$p_s = \frac{E\delta}{r_s \left[\frac{r_o^2 + r_s^2}{r_o^2 - r_s^2} + \frac{r_s^2 + r_i^2}{r_s^2 - r_i^2} \right]}$$

The combined stress distribution in a shrink fit composite cylinder is made up of stress distribution in the inner and outer cylinders and this is shown in **figure-9.2.2.3**.

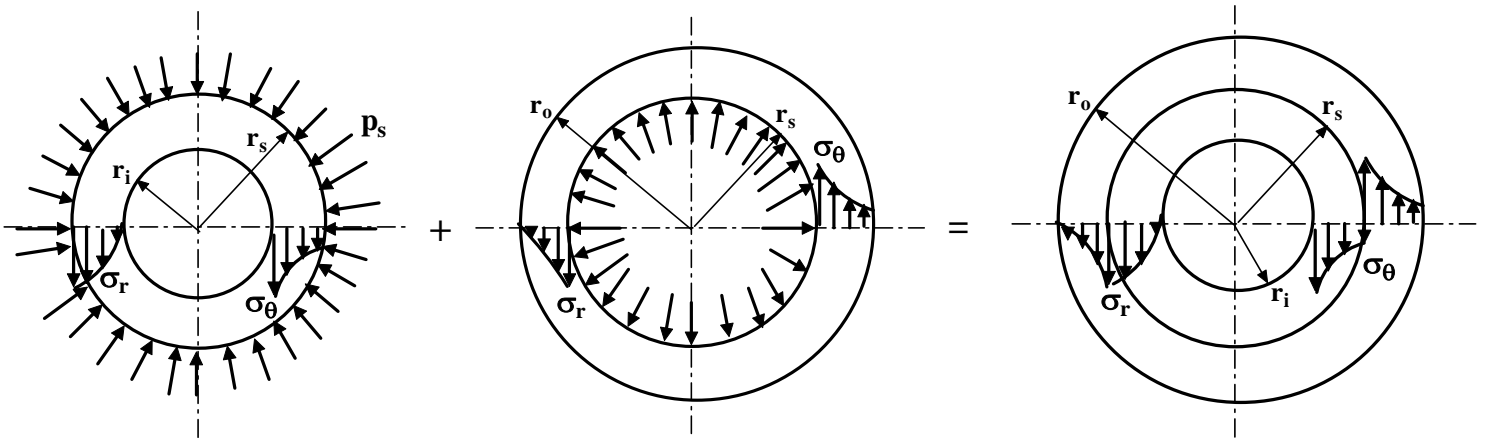

9.2.2.3F- Combined stress distribution in a composite cylinder.

Residual circumferential stress is maximum at $r = r_i$ for the inner cylinder and is given by

$$\sigma_{\theta(\max)} \Big|_{r=r_i} = -\frac{2p_s r_s^2}{r_s^2 - r_i^2}$$

Residual circumferential stress is maximum at $r = r_s$ for the outer cylinder and is given by

$$\sigma_{\theta(\max)} \Big|_{r=r_s} = p_s \frac{r_o^2 + r_s^2}{r_o^2 - r_s^2}$$

Stresses due to fluid pressure must be superimposed on this to find the complete stress distribution.

2. Multilayered or Laminated cylinder

The laminated cylinders are made by stretching the shells in tension and then welding along a longitudinal seam. This is shown in **figure- 9.2.2.4**.

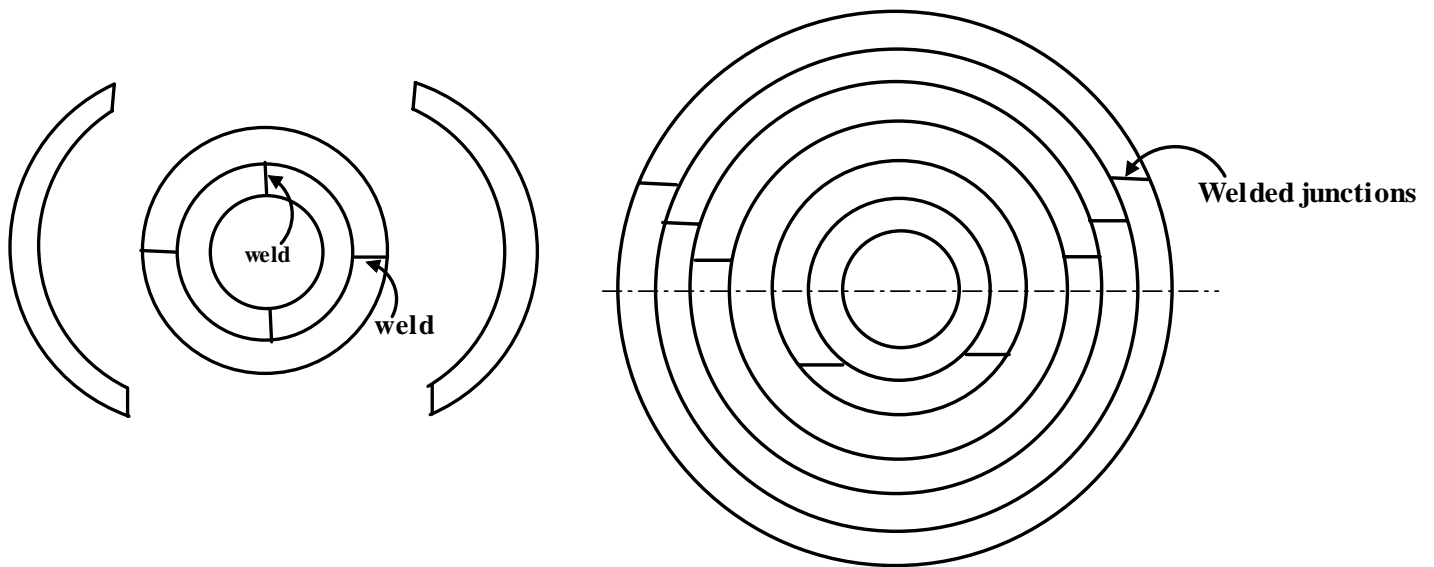

9.2.2.4F- Method of construction of multilayered cylinder

3. Autofrettage

In some applications of thick cylinders such as gun barrels no inelastic deformation is permitted. But for some pressure vessel design satisfactory function can be maintained until the inelastic deformation that starts at inner bore spreads completely over the wall thickness. With the increase in fluid pressure yielding would start at the inner bore and then with further increase in fluid pressure yielding would spread outward. If now the pressure is released the outer elastic layer would regain its original size and exert a radial compression on the inner shell and tension on the outer region.

This gives the same effect as that obtained by shrinking a hoop over an inner cylinder. This is known as **Self- hooping** or **Autofrettage**. This allows the cylinder to operate at higher fluid pressure. For a given autofrettage fluid pressure a given amount of inelastic deformation is produced and therefore in service the same fluid pressure may be used without causing any additional inelastic deformation.

9.2.3 Summary of this Lesson

Stresses and strains in thick cylinders are first discussed and Lamé's equations are derived. Radial and circumferential stress distribution across the wall thickness in thick cylinders have been illustrated. Methods of increasing elastic strength of a thick cylinder by prestressing are then discussed. Interface pressure and displacement during shrinking a hollow cylinder over the main cylinder have been expressed in terms of known variables. Finally multilayered or laminated cylinders and autofrettage are discussed.

Source:

<http://nptel.ac.in/courses/Webcourse-contents/IIT%20Kharagpur/Machine%20design1/pdf/module-9%20lesson-2.pdf>