Vibration Generations Mechanisms: Source Classification

Introduction

In classical acoustics/vibrations, which were largely developed during the 19-th century, the essential aspects of sound and vibration in a fluid can only be radiated by vibrating solid bodies. Driving the vibration of such bodies are dynamic forces of various kinds, e.g., inertial forces in connection with shocks and electromagnetic forces, as is the case with common loudspeakers. Thus, we will give due attention to sound and vibration emission from vibrating structures, particularly large plates. The most important contribution to the sound and vibration radiation from a plate is from bending waves. That type of wave primarily involves motions perpendicular to the plane of the plate, and can therefore excite sound and vibration waves in a surrounding fluid. It is, however, apparent to all who have listened to water boiling in a kettle, or the sound and vibration of airplane starting up, that there must be other mechanisms of sound and vibration radiation than vibrating solid bodies. Vibration can be defined as simply the cyclic or oscillating motion of a machine or machine component from its position of rest. Forces generated within the machine cause vibration. These forces may:

1. Change in direction with time, such as the force generated by a rotating unbalance.
2. Change in amplitude or intensity with time, such as the unbalanced magnetic forces generated in an induction motor due to unequal air gap between the motor armature and stator (field).
3. Result in friction between rotating and stationary machine components in much the same way that friction from a rosined bow causes a violin string to vibrate.
4. Cause impacts, such as gear tooth contacts or the impacts generated by the rolling elements of a bearing passing over flaws in the bearing raceways.
5. Cause randomly generated forces such as flow turbulence in fluid-handling devices such as fans, blowers and pumps; or combustion turbulence in gas turbines or boilers.

Rotating machinery deteriorates over time and develops faults. They are to be corrected to provide long life and uninterrupted service to the extent possible. Once

any of these faults are developed, they provide symptoms, most significant of them being vibration signatures. Some of the most common machinery problems that cause vibration include:

- Rotor unbalance
- Reciprocating unbalance
- Permanent bow (Bent shaft or warped shaft)
- Rolling element bearing damage
- Oil film excited vibrations
- Casing or Foundation distortion
- Steam whirl
- Seal rub and Rotor axial rub
- Insufficient tightness in assembly of: Rotor (shrink-fits), Bearing liner, case, Casing and support
- Misalignment
- Instabilities due to kinematic constraints
- Cracks
- Gear inaccuracy or damage
- Piping forces
- Journal and bearing eccentricity
- Bearing and support excited vibration
- Unequal x and y bearing stiffness
- Variable inertia from reciprocating parts
- Electrical unbalance
- Aerodynamic excitation
- Thrust bearing damage
- Coupling inaccuracy
- Structural resonance
- Critical speeds
- Pressure pulsations
- Oil seal induced vibration
- Torsional resonances

An unbalance in a rotor denotes that the center of gravity and the geometric center of a disk are not at the same location. These two points can never be same even for a

perfectly made disk, since no material is homogenous. Most of the disks are made to carry attachments like blades; all the blades mounted cannot be exactly identical. Generator rotors are made with several windings and they cannot be manufactured to be perfectly symmetrical in all respects.

4.1 Typical Causes of Rotor Unbalance (JS Rao, 1998)

Cause of Unbalance	Observed Signs	Frequency of Vibration
Disk or Component eccentric on shafts	Detectable runout on slow rotation - runs to bottom on knife edges	one per rev
Dimensional inaccuracies	Measurable lack of symmetry	one per rev
Eccentric machining or forming inaccuracies	Detectable runout	one per rev
Oblique angled component	Detectable angular runout - Measure with a dial gauge on knife edges	one per rev
Bent shaft, distorted assembly, stress relaxation with time	Detectable runout on slow rotation, often heavy vibration during rotation	one per rev
Section of blade or vane broken off	Observable Bearing vibration during operation	one per rev, Possible process pulsations
Eccentric accumulation of process dirt on blade	Bearing vibration	one per rev
Differential thermal expansion	Shaft bends throws c.g. out Source of heavy vibration	one per rev
Trapped fluid inside rotor Possible condensing/vaporizing with process cycle	Vibration reappears after balancing, Apparent c.g. angular movement Occurs	one per rev Possible magnitude and phase changes

A residual unbalance in a rotor and that a good design can keep it to a minimum value, the operation of a machine, however gets this unbalance condition deteriorates over a period. There could be erosion due to particle impact in a high speed flow, corrosion in a wet steam environment on the mounted parts like blades or any of several reasons that could be responsible to make the center of gravity change its position during the running time of a machine. The centrifugal force is simply $m\omega^2$ directed radially outward and passing through the c.g. from the center of rotation.

Well balanced rotors are sometimes subjected to deformations while running or under stationary conditions. Typically they arise from thermal stresses when the rotor is not properly stabilized. Such a rotor is called Bowed Rotor or a rotor with Permanent Bow. A bowed rotor can be considered as the Jeffcott model in Fig. 4.1 with a static deflection from the bearing center line with a magnitude r_0 at a phase angle α_0 ,

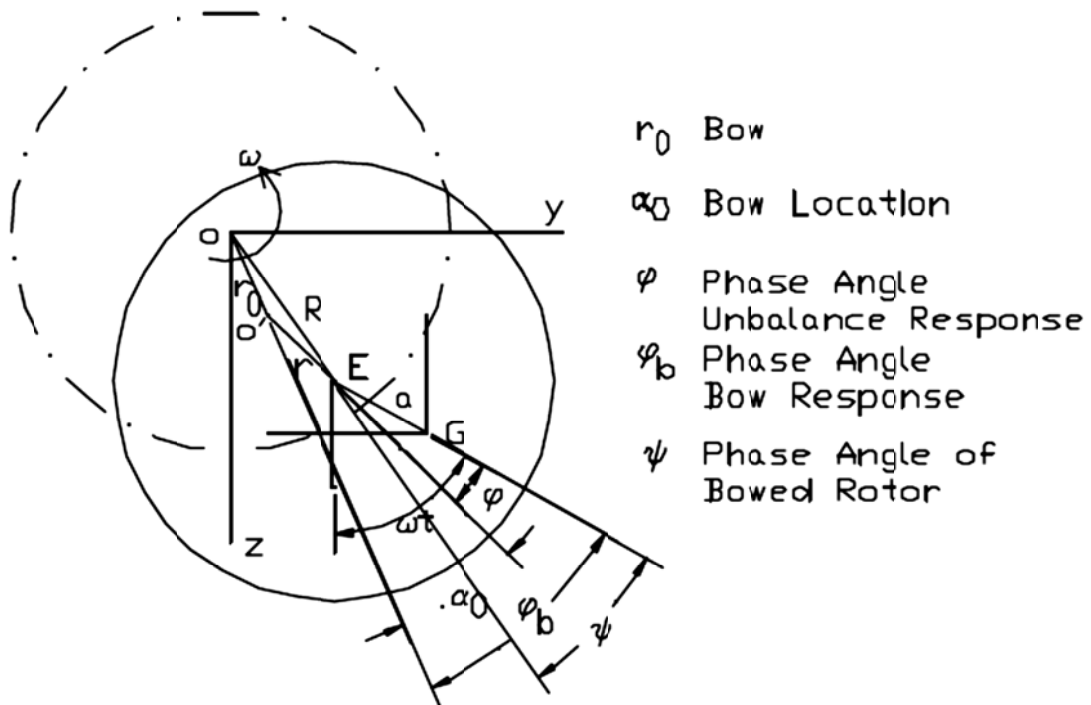

Fig. 4.1 Unbalance Whirl Geometry with Bow

If the rotor whirl amplitude decreases before the critical speed, it indicates that there is rotor bow present in phase opposition with the unbalance. At high speeds the unbalance predominates and the bow being in opposition to the unbalance plays no role, the amplitude reaches a value of unity as in the case of pure unbalance response.

Unbalance phenomena:

- Most common cause and the easiest to diagnose.
- Condition where center of mass is not coincident with center of rotation
- Typical causes: casting porosity, nonuniform density, loss of material during operation, manufacturing tolerances, machining, couplings, bearings, anything that affects the rotational mass distribution
- Shows up as a vibration frequency exactly equal to the rotational speed (amplitude proportional to the amount of unbalance). Must do frequency analysis to

diagnose.

- Speed dependent due to centrifugal force; vibration increases as the square of the speed
- Low axial readings, In phase
- Unbalanced and balanced motor spectrum

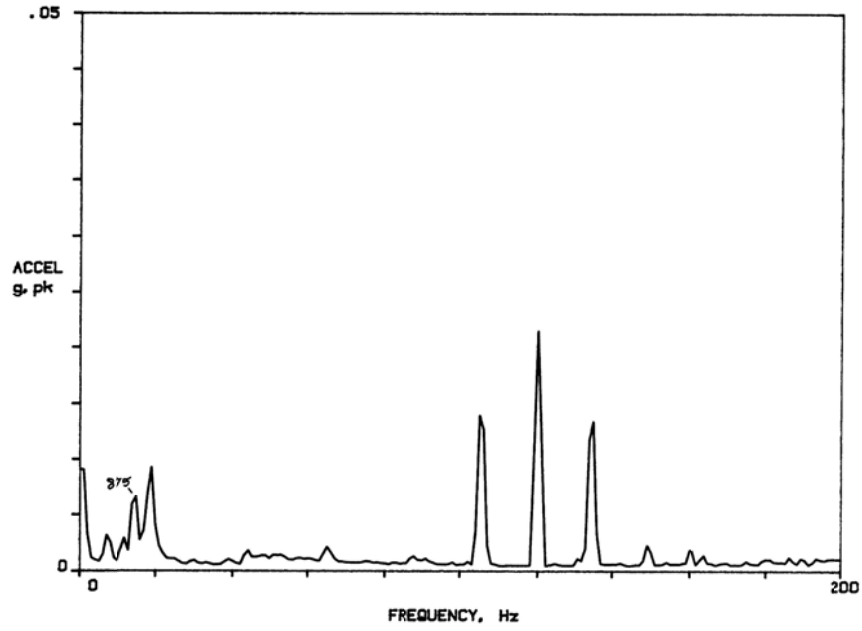

(a)

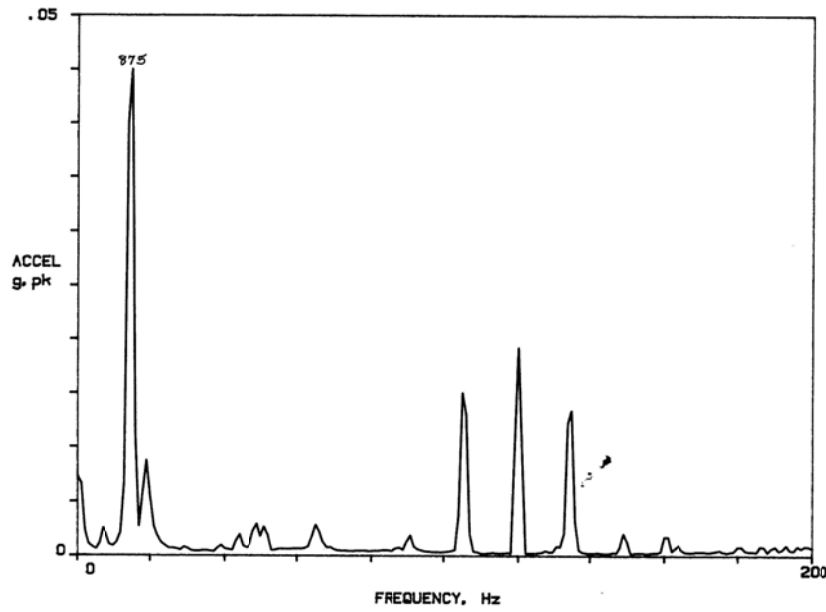

(b)

Fig. 4.2 Vibration Signature (a) Balance rotor (b) Unbalance rotor (Wonk, Machinery Vibration)

Misalignment Phenomena:

- Coupling misalignment- shafts of the driver and the driven machine are not on the same centerline (parallel or angular)
- Vertical or Horizontal- can be frustrating
- Why misalignment? Equipment from different suppliers are mated together. Example: motors and pumps (centrifugal pump)
- Flexible couplings are used to take up misalignment (but could strain the couplings, bearings and seals)
- Shows up as a series of harmonics of the running speed- as shafts are cyclically strained towards each other (audible growl of misalignment)
- Misalignment is temperature dependent (vibration changes on warm up)
- High axial readings
- ~180 degrees out of phase (machine casing rocks out of phase with the machine)
- Less sensitive to speed changes. Forces due to misalignment remain constant with speed
- Align first; and if a high 1X rpm vibration remains, then balance.

Resonance:

- Driving force applied to a structure is close to its natural frequency and amplification occurs.
- Driving force can be residual imbalance in a rotating machine or broadband turbulence due to fluid motion.
- Beams, plates have resonant frequencies, not just one (for single dof)
- Resonance is highly speed sensitive, damping decreases the maximum amplitude and broadens the response curve
- Rotors have resonances (critical speeds)- remember rotors runs smoother above the critical speed than below it; example: squeaking in an automobile at highway speeds goes away with a change in speed
- An impulse will excite the system to natural frequencies
- Directional vibrations suggest resonance
- Key indicators: an audible pure tone, a clean sine wave in the time domain and a single tall peak in the frequency domain

Identifying Resonance

- Stop the machine, do the bump test, measure natural frequencies. If these frequencies appear in the spectrum when the machine is running, then you have confirmed resonance.
- The second way is to watch the spectrum as the machine changes speed (coast-down). The resonances don't change frequency as the machine speed changes.

Breakdown of all Vibration Problems are mainly due to

- 40% Unbalance
- 30% Misalignment
- 20% Resonance
- 10% Others

Characteristics of vibration

Vibration is simply defined as "the cyclic or oscillating motion of a machine or machine component from its position of rest or its 'neutral' position."

Whenever vibration occurs, there are actually four (4) forces involved that determine the characteristics of the vibration. These forces are:

1. The exciting force, such as unbalance or misalignment.
2. The mass of the vibrating system, denoted by the symbol (M).
3. The stiffness of the vibrating system, denoted by the symbol (K).
4. The damping characteristics of the vibrating system, denoted by the symbol (C).

The exciting force is trying to cause vibration, whereas the stiffness, mass and damping forces are trying to oppose the exciting force and control or minimize the vibration. Perhaps the simplest and easiest way to demonstrate and explain vibration and its measurable characteristics is to follow the motion of a weight suspended by a spring. This is a valid analogy since all machines and their components have weight (mass), spring-like properties (stiffness) and damping. In the real world of vibration detection and analysis, it is not necessary to determine the frequency of vibration by observing the vibration time waveform, noting the period of the vibration and then taking and calculating the inverse of the period to find the frequency - although this can be done. Nearly all modern- day data collector instruments and vibration

analyzers provide a direct readout of the vibration frequencies being generated by the machine.

Vibration detection and analysis play important roles in the development and testing of new or prototype machines. Vibration measurements provide overall performance data. Analysis techniques reveal troubles that might be the result of improper installation and adjustment as well as improper design.

Field Service: In spite of the many engineering tests and quality control inspections, vibration problems do occur once a machine is delivered, installed and brought into service.

Such problems may include:

- Damage to the machine during transportation or installation
- Improper alignment of couplings or pulleys
- Weak or inadequate base or foundation
- Resonance of the machine or a machine component
- Distortion due to "soft foot" or piping strain
- Machine operating outside designed performance parameters
- Improper design of related components such as piping, duct work, etc.

Due to the multitude of problems that can result in vibratory forces, a complete vibration analysis of the complete installation is often the only way to clearly define the source of a problem and the corrective action required for its solution.

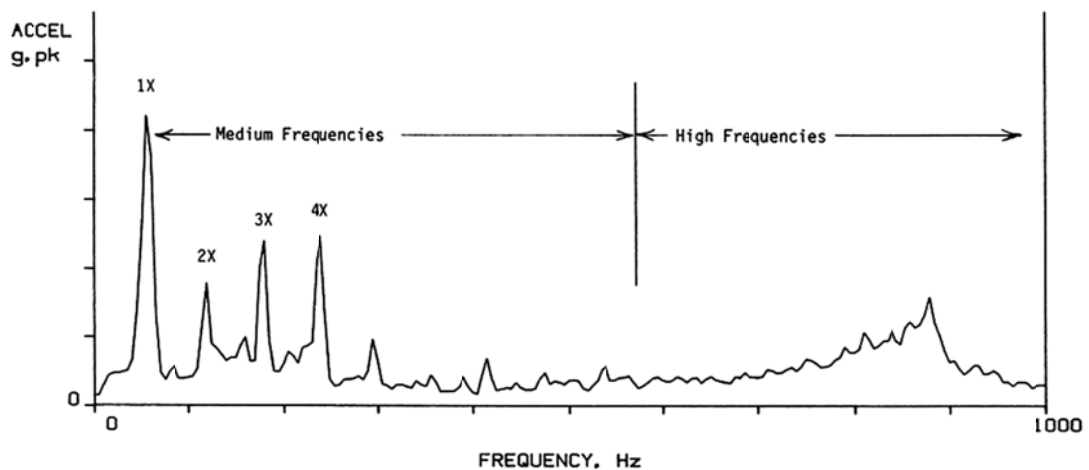

Fig. 4.3 Vibration Signature

4.2 Common Machinery Faults

Cause	Frequency	Amplitude
Less than 1x rpm		
Difference frequency almost the same speed		Comes and goes, caused by two machines running at
Oil whirl with plain bearings	Approx. 45% of 1x rpm	Applicable to high speed machines
Looseness	1/2, 1 1/2, 2 1/2, etc	Decreases with load
Belts defect	$\pi(\text{rpm})(\text{pitch dia.})$	Note: Strobe light helps to see the
Resonance amplitudes	Discrete peaks	A serious condition with very high
At 1x rpm		
Unbalance	1x rpm	Mostly radial; a common fault
Misalignment common fault	1x rpm + harmonics	High 2x and 3x; high axial; a
Eccentricity corrected with weights	1x rpm	Looks like unbalance; cannot be
Looks like unbalance; can be corrected with massive balance weights near the center		
Soft foot loosening one hold down bolt	1x rpm	Dramatically decreases by
Reciprocating misfiring	1x rpm + harmonics	More than 0.005 inches indicates
Medium frequencies		
Misalignment temperature; a common fault	2x, 3x, + harmonics	High axial; changes with
Motor (electrical) disconnecting power. Also causes	120 Hz + harmonics	Stops immediately upon
120 Hz sidebands at higher frequencies. Not usually destructive; an indication of the quality of construction. Present on all motors and transformers to some degree.		
Looseness	1/2, 1 1/2, 2 1/2, etc.	Decreases with load
Bearings time domain	FTF = 0.4 x rpm OR = 0.4xRPMxN IR = 0.6xRPMxN N= no. of balls	High frequency shock pulses in
Blades	rpm x (no of blades)	Benign
High frequencies		
Gears 2x gear mesh usually larger	rpm x (no of teeth)	Sidebands at gear mesh frequency;
Cavitation helps	3-5 kHz broadband	Usually benign; pressurizing inlet
Bearing	Broadband	High frequency shock pulses

Root Cause Analysis

Machine vibration has several categories of causes that are discovered sometimes after repair, but it is useful now to review them to gain more confidence in the diagnosis. The major categories are –

- design defects

- manufacturing defects
- operational stresses
- maintenance actions
- aging

Design defects are mostly structural related with active resonances built-in because of improper sizing and proportioning of the parts. Statically, the structure is O.K., but is dynamically weak. This is not discovered until the machine is energized and brought up to speed. This is more common than it should be, but designers are not well equipped to predict or test for natural frequencies. In addition, the owners' foundation or base has a significant effect on natural frequencies, which the designer has little control over. Hence, resonances are best detected during startup testing and corrected on-site with strategic stiffeners added.

Manufacturing defects are built-in during the casting, machining, heat-treating, and assembly processes. They are latent defects that may show up in the first 24-hours of running, or they may not be obvious during the run-in period, rather appearing years later. The machine does not survive to a normal life expectancy. Vibration may or may not be present. An example is residual stresses in a shaft that gradually distorts the shaft over a period of years. Manufacturing defects are difficult to control, impossible to predict, and elusive to fix. The best strategy to deal with both design defects and manufacturing defects is to insist on startup vibration testing with limits of acceptability in accordance with Table 1.

Excessive operational stresses can develop due to material buildup or erosion that changes the balance condition, or thermal expansion that changes component alignment. Both of these cause high dynamic loads at the bearings which lead to accelerated wear out. These defects are easily detected with periodic vibration measurements and there are well established methods to correct them on site.

Maintenance actions, or inactions, are the most common cause of machine failure. It is well known in the repair business that a machine never goes back together the same way. Some of this is due to rough handling, but some is simply the fact that field repair is less controlled than the original factory build. The field environment is darker, dirtier, and less precise tooling is available to control fits and alignments. The repair is usually rushed by management. It is surprisingly difficult to install a bearing into an aluminum housing in the field and not get it crooked. The first question to ask

in vibration analysis is “What recent maintenance activity has occurred on this machine?” Other maintenance activities that affect vibration are –

- excessive localized heating, like welding on a shaft
- too high belt tension
- shaft, or bearing, misalignment
- substandard replacement parts
- coupling, or other component, binding
- lack of lubrication
- loose hardware
- replacing hardware with different weights that affect balance
- re-assembling hardware in different orientations (also affects balance)
- hammering on a bearing
- unclean, or burred, precision machine surfaces

Aging effects can only be detected with long term vibration monitoring. The two dominant aging effects are residual stress relaxation and softening of structural joints. The residual stresses left behind in machine components will always relieve themselves over time. This process is accelerated at higher temperature. Shafts, being long and slender components, are particularly vulnerable to bowing. The symptoms are an increase in 1xRPM balance condition and beating up of the bearings. Bearing replacements do not restore the original smooth running condition, and mass balancing is unsuccessful, until the shaft is replaced.

All joints soften over time, and joints are the weak links in any structure. The subtle symptom of this is lowering of the natural frequencies. This is usually first detected with high vibration when the lowest natural frequency drops down into the operating speed range of the machine. In the professional field of machine vibration analysis, we are all guilty, at one time or another, of making the false assumptions initially that machines are well designed, well manufactured, well operated, well maintained, and that nothing changes with time.

“Fundamentals of Sound and Vibrations” by KTH Sweden [1], this book is used under IITR-KTH MOU for course development.

Source:

<http://nptel.ac.in/courses/112107088/13>