



# UNIFIED FACILITIES CRITERIA (UFC)

## BOILER CONTROL SYSTEMS

U.S. ARMY CORPS OF ENGINEERS

NAVAL FACILITIES ENGINEERING COMMAND (Preparing Activity)

AIR FORCE CIVIL ENGINEER SUPPORT AGENCY

**APPROVED FOR PUBLIC RELEASE: DISTRIBUTION UNLIMITED**

**UNIFIED FACILITIES CRITERIA (UFC)**

**BOILER CONTROL SYSTEMS**

Any copyrighted material included in this UFC is identified at its point of use.  
Use of the copyrighted material apart from this UFC must have the permission of the  
copyright holder.

Record of Changes (changes indicated by \1\ ... /1/ )  
Change No.    Date            Location

---

**This UFC supersedes Military Handbook MIL-HDBK-1003/12, dated 31 October  
1989.**

## FOREWORD

The Unified Facilities Criteria (UFC) system is prescribed by MIL-STD 3007 and provides planning, design, construction, sustainment, restoration, and modernization criteria, and applies to the Military Departments, the Defense Agencies, and the DoD Field Activities in accordance with [USD\(AT&L\) Memorandum](#) dated 29 May 2002. UFC will be used for all DoD projects and work for other customers where appropriate. All construction outside of the United States is also governed by Status of forces Agreements (SOFA), Host Nation Funded Construction Agreements (HNFA), and in some instances, Bilateral Infrastructure Agreements (BIA.) Therefore, the acquisition team must ensure compliance with the more stringent of the UFC, the SOFA, the HNFA, and the BIA, as applicable.

UFC are living documents and will be periodically reviewed, updated, and made available to users as part of the Services' responsibility for providing technical criteria for military construction. Headquarters, U.S. Army Corps of Engineers (HQUSACE), Naval Facilities Engineering Command (NAVFAC), and Air Force Civil Engineer Support Agency (AFCESA) are responsible for administration of the UFC system. Defense agencies should contact the preparing service for document interpretation and improvements. Technical content of UFC is the responsibility of the cognizant DoD working group. Recommended changes with supporting rationale should be sent to the respective service proponent office by the following electronic form: [Criteria Change Request \(CCR\)](#). The form is also accessible from the Internet sites listed below.

UFC are effective upon issuance and are distributed only in electronic media from the following source:

- Whole Building Design Guide web site <http://dod.wbdg.org/>.

Hard copies of UFC printed from electronic media should be checked against the current electronic version prior to use to ensure that they are current.

### AUTHORIZED BY:



DONALD L. BASHAM, P.E.  
Chief, Engineering and Construction  
U.S. Army Corps of Engineers



DR. JAMES W. WRIGHT, P.E.  
Chief Engineer  
Naval Facilities Engineering Command

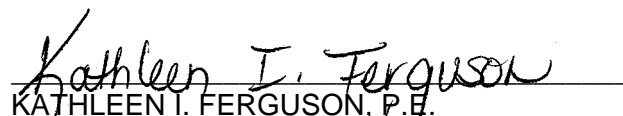

KATHLEEN I. FERGUSON, P.E.  
The Deputy Civil Engineer  
DCS/Installations & Logistics  
Department of the Air Force



Dr. GET W. MOY, P.E.  
Director, Installations Requirements and  
Management  
Office of the Deputy Under Secretary of Defense  
(Installations and Environment)

## CONTENTS

		Page
<b>CHAPTER 1 INTRODUCTION</b>		
Paragraph	1-1	PURPOSE AND SCOPE ..... 1-1
	1-2	REFERENCES ..... 1-1
	1-3	DEFINITIONS ..... 1-1
<b>CHAPTER 2 TYPES OF CONTROLS</b>		
Paragraph	2-1	GENERAL ..... 2-1
	2-2	CONTROL SELECTION ..... 2-1
	2-3	PNEUMATIC CHARACTERISTICS ..... 2-1
	2-3.1	Air Supply Pressure ..... 2-1
	2-3.2	Design Considerations ..... 2-2
	2-3.3	Service Tubing Size ..... 2-2
	2-3.4	Control Distance ..... 2-2
	2-3.5	Instrument Air Regulation ..... 2-2
	2-4	ELECTRICAL CHARACTERISTICS ..... 2-2
	2-4.1	Electrical Interface ..... 2-2
	2-4.2	Communication Data Bus ..... 2-2
<b>CHAPTER 3 GENERAL REQUIREMENTS</b>		
Paragraph	3-1	GENERAL ..... 3-1
	3-2	CONTROL LOCATION ..... 3-1
	3-3	TURNDOWN ..... 3-1
	3-4	INSTRUMENT RANGES ..... 3-1
	3-5	ALARMS AND SHUTDOWNS ..... 3-1
	3-5.1	Design Criteria ..... 3-1
	3-5.2	Testing and Servicing ..... 3-1
	3-5.3	Interlock and Safety Requirements ..... 3-2
	3-5.3.1	Safety Interlocks ..... 3-2
	3-5.3.2	Shutdown Valve Reset ..... 3-2
	3-5.3.3	Dedicated Safety System ..... 3-2
	3-5.3.4	Special Considerations ..... 3-3
	3-6	HARDWARE ..... 3-3
	3-7	EQUIPMENT RATING AND CLASSIFICATION ..... 3-3
	3-7.1	Enclosures ..... 3-3
	3-7.2	Hazardous Locations ..... 3-5
	3-7.2.1	Class Definition ..... 3-5
	3-7.2.2	Division Definition ..... 3-5
	3-7.2.3	Group Definition ..... 3-5
	3-7.3	Special Considerations ..... 3-5
	3-7.3.1	Maintenance ..... 3-5
	3-7.3.2	Specification Completeness ..... 3-6

3-8	POWER SUPPLIES.....	3-6
3-9	INSTRUMENT AIR.....	3-6
3-10	WIRING AND CONDUITS .....	3-6
3-11	INSTRUMENT TUBING AND PIPING.....	3-7
3-12	IDENTIFICATION.....	3-7
3-12.1	Nameplates .....	3-7
3-12.2	Terminations .....	3-7
3-12.3	Instruments.....	3-7
3-13	INSTRUMENT SPECIFICATION FORMS .....	3-7
3-14	DRAWINGS.....	3-7
3-15	CODE REQUIREMENTS .....	3-8
3-16	STANDARDIZATION.....	3-8
3-16.1	Multiple Manufacturers .....	3-8
3-16.2	Packaged Equipment.....	3-8
3-16.3	Special Considerations.....	3-8
3-16.3.1	Signal Amplitude.....	3-8
3-16.3.2	Connections .....	3-8
3-16.3.3	Recorders .....	3-8
3-17	ENVIRONMENTAL CONCERNS .....	3-9
3-18	SAFETY PLAN AND HAZOP STUDY.....	3-9

## CHAPTER 4 PANEL INSTRUMENTS

Paragraph	4-1	GENERAL .....	4-1
	4-1.1	Types of Control Panels .....	4-1
	4-1.2	Panel Location .....	4-1
	4-1.2.1	Control Room Panels.....	4-1
	4-1.2.2	Local Panels .....	4-1
	4-1.3	Layout.....	4-1
	4-1.4	Construction .....	4-2
	4-1.4.1	Electrical Components.....	4-2
	4-1.4.2	Displays.....	4-2
	4-1.4.3	Lighting.....	4-2
	4-1.4.4	Service Outlets .....	4-2
	4-1.4.5	Steelwork .....	4-2
	4-1.4.6	Prefabrication.....	4-2
	4-2	INDIVIDUAL ITEM REQUIREMENTS .....	4-2
	4-2.1	Controllers .....	4-2
	4-2.1.1	Process Controllers.....	4-3
	4-2.1.1.1	Control Modes.....	4-3
	4-2.1.1.2	Testing.....	4-3
	4-2.1.1.3	Controls .....	4-3
	4-2.1.1.4	Alarms .....	4-3
	4-2.1.1.5	Displays.....	4-4
	4-2.1.1.6	Features.....	4-4
	4-2.1.1.7	Failure Response .....	4-4
	4-2.1.1.8	Signal Interface.....	4-4

4-2.1.2	Programmable Logic Controllers .....	4-5
4-2.1.3	Controller Configuration .....	4-5
4-2.2	Recorders .....	4-5
4-2.3	Totalizers .....	4-5
4-2.4	Indicators .....	4-5
4-2.5	Status Lights .....	4-5
4-2.6	Annunciators .....	4-6
4-2.6.1	Common Alarms .....	4-6
4-2.6.2	Dedicated Alarms .....	4-6
4-2.6.3	Annunciator Systems .....	4-6
4-2.6.4	Alarm Indications .....	4-6
4-2.7	Selector Switches .....	4-6
4-2.8	Pushbuttons .....	4-7
4-2.9	Plant Control Stations .....	4-7
4-2.9.1	Computers .....	4-7
4-2.9.1.1	Control Limits .....	4-7
4-2.9.1.2	Data Overflow Alarm.....	4-7
4-2.9.1.3	Redundancy .....	4-7
4-2.9.2	Monitors .....	4-7
4-2.9.3	Keyboards .....	4-7
4-2.9.4	Printers and Plotters .....	4-7
4.2.10	Data Logging .....	4-7
4.2.11	Receiver Instruments .....	4-8
4-2.12	Potentiometer Instruments.....	4-8

## CHAPTER 5 LOCAL DEVICES AND INSTRUMENTATION

Paragraph	5-1	GENERAL .....	5-1
	5-2	INDIVIDUAL ITEM REQUIREMENTS .....	5-1
	5-2.1	Valves.....	5-1
	5-2.1.1	Control Valves.....	5-1
	5-2.1.1.1	Design Checklist .....	5-1
	5-2.1.1.2	Construction .....	5-1
	5-2.1.1.3	Sizing .....	5-1
	5-2.1.1.4	Maintenance.....	5-2
	5-2.1.1.5	Location .....	5-2
	5-2.1.2	Pressure Regulators .....	5-2
	5-2.1.3	Solenoid Valves .....	5-2
	5-2.2	Actuators.....	5-2
	5-2.3	Current to Pneumatic Converters .....	5-2
	5-2.4	Dampers .....	5-3
	5-2.5	Pressure Relief Valves .....	5-3
	5-2.6	Rupture Disks .....	5-3
	5-2.7	Level Instruments .....	5-3
	5-2.7.1	Gauge Glasses .....	5-3
	5-2.7.2	Displacer.....	5-3
	5-2.7.3	Differential Pressure .....	5-3

5-2.7.4	Capacitance Level.....	5-3
5-2.8	Flow Instruments .....	5-4
5-2.8.1	Meter Runs .....	5-4
5-2.8.1.1	Requirements.....	5-4
5-2.8.1.2	Straightening Vanes.....	5-4
5-2.8.1.3	Fabrication.....	5-4
5-2.8.2	Orifice Plates .....	5-4
5-2.8.2.1	Design.....	5-5
5-2.8.2.2	Mounting .....	5-5
5-2.8.2.3	Construction .....	5-5
5-2.8.3	Flow Nozzles .....	5-5
5-2.8.4	Venturi Tubes.....	5-5
5-2.8.5	Elbow Meters .....	5-6
5-2.8.6	Pitot Tubes .....	5-6
5-2.8.7	Rotometers.....	5-6
5-2.8.8	Magnetic Flowmeters.....	5-6
5-2.8.9	Positive Displacement Meters .....	5-6
5-2.8.10	Turbine Meters.....	5-6
5-2.8.11	Vortex Meters.....	5-6
5-2.8.12	Annubar Meters .....	5-6
5-2.9	Temperature Measurements .....	5-6
5-2.9.1	Thermowells .....	5-7
5-2.9.2	Thermocouples .....	5-7
5-2.9.3	Resistance-Temperature Detectors .....	5-7
5-2.9.4	Filled Bulb Systems .....	5-7
5-2.9.5	Bimetallic Thermometers .....	5-7
5-2.10	Pressure Measurements .....	5-7
5-2.10.1	Gauges.....	5-8
5-2.10.2	Switches.....	5-8
5-2.10.3	Transmitters .....	5-8
5-2.10.4	Draft.....	5-8
5-2.11	Electronic Transmitters.....	5-8
5-2.12	Electrical Instrument Switches .....	5-9
5-2.13	Analyzers .....	5-9
5-2.13.1	General Guidelines .....	5-9
5-2.13.1.1	Calibration .....	5-9
5-2.13.1.2	Application.....	5-9
5-2.13.1.3	Packaging.....	5-9
5-2.13.2	Oxygen Analyzer .....	5-10
5-2.13.3	Combustibles Analyzer.....	5-10
5-2.13.3.1	Carbon Monoxide Analyzer .....	5-10
5-2.13.3.2	Hydrogen Analyzer.....	5-10
5-2.13.4	Stack Opacity Analyzer .....	5-10
5-2.13.5	Conductivity Analyzer .....	5-11
5-2.13.6	Methane Analyzer .....	5-11
5-2.14	Flame Detectors .....	5-11
5-2.15	Continuous Emission Monitoring (CEM).....	5-11

## CHAPTER 6 RECOMMENDED BOILER INSTRUMENTATION

Paragraph	6-1	BOILER CONTROL PANEL INDICATORS, RECORDERS, AND TOTALIZERS .....	6-1
	6-2	BOILER CONTROL PANEL ALARMS AND SHUTDOWNS..	6-1
	6-3	BOILER CONTROL PANEL CONTROLLERS .....	6-2
	6-4	VALUE ENGINEERING .....	6-2

## CHAPTER 7 CONTROL LOOPS

Paragraph	7-1	GENERAL .....	7-1
	7-2	CONTROL LOOP TYPES.....	7-1
	7-2.1	Pressure.....	7-1
	7-2.2	Temperature.....	7-1
	7-2.3	Level .....	7-1
	7-2.4	Flow .....	7-1
	7-3	AIR TO FUEL RATIO.....	7-1
	7-3.1	Control Configuration.....	7-2
	7-3.2	Fuel Changeover .....	7-2
	7-3.3	Simultaneous Fuel Firing .....	7-2
	7-3.4	Alarms .....	7-2
	7-4	BOILER DRUM LEVEL.....	7-2
	7-4.1	Single Element Control.....	7-2
	7-4.2	Two Element Control .....	7-2
	7-4.3	Three Element Control .....	7-2
	7-5	MULTIPLE BOILERS .....	7-3

APPENDIX A	REFERENCES.....	A-1
------------	-----------------	-----



## FIGURES

<u>Figure</u>	<u>Title</u>	
7-1	Typical Control Loop .....	7-4
7-2	Typical Pressure Control Loop .....	7-5
7-3	Typical Temperature Control Loop .....	7-5
7-4	Typical Level Control Loop .....	7-6
7-5	Typical Flow Control Loop .....	7-6
7-6	Typical Cross-Limited (Lead-Lag) Boiler Control System for a Single Fuel Using Full Metering with Oxygen Trim .....	7-7
7-7	Single Element Drum Level Control System .....	7-8
7-8	Two Element Drum Level Control System .....	7-9
7-9	Three Element Drum Level Control System .....	7-10
7-10	Multiple Boiler Control Loop – Control Master .....	7-11

## TABLES

<u>Table</u>	<u>Title</u>	
3-1	Enclosure Ratings .....	3-4
6-1	Boiler Control Panel Indicators, Recorders, and Totalizers .....	6-3
6-2	Boiler Control Panel Alarms and Shutdowns .....	6-5

## CHAPTER 1

### INTRODUCTION

1-1 **PURPOSE AND SCOPE.** This document provides criteria for the design of heating plant instrumentation. A heating plant contains one or more boilers. The plant may be an individual plant serving a single building or a compact group of buildings, or a central plant serving many buildings and facilities through an extensive distribution system. The heating plant instrumentation discussed is, in general, for a saturated-steam power boiler heating plant. The typical saturated-steam power boiler heating plant discussed will operate at a design steam pressure of between 1.03 bar (15 psig) and 20.68 bar (300 psig), with a heating capacity of greater than 422 megajoule/h (400,000 Btu/h).

The information provided may also be applicable to Low, Medium, and High Temperature Hot Water heating plants, but does not cover all of the requirements of those plants, such as control of water pressurization and circulation systems. The information may also be applicable to superheated-steam power plants, but does not cover the all of the requirements of those plants, such as steam extraction, reheating, steam turbine control, and cooling water controls.

Instrumentation is a rapidly changing field. The options available in choosing and designing plant instrumentation are numerous. A boiler plant includes a large number of instrument items, all of which have to be specified in the procurement of a boiler plant. This handbook does not attempt to cover all details. Rather, its purpose is to present general guidelines for selecting and designing instrumentation for boiler plants.

1-2 **REFERENCES.** Refer to Appendix A for references applicable to this document.

1-3 **DEFINITIONS.**

Heating Boiler – A boiler operated at pressures not exceeding 1.03 bar (15 psig) for steam, or for Low Temperature Hot Water (LTW) at pressures not exceeding 10.98 bar (160 psig) and temperatures not exceeding 121.1 degrees C (250 degrees F) for water.

High Pressure Power Boiler – A power boiler operated at pressures exceeding 20.68 bar (300 psig) for steam, or for High Temperature Hot Water (HTW) at pressures exceeding 10.98 bar (160 psig) and temperatures exceeding 176.6 degrees C (350 degrees F) (but not exceeding 215.5 degrees C (420 degrees F)) for water. HTW pressure must exceed saturation pressure plus 1.72 bar (25 psig) to avoid cavitation.

Power Boiler – A boiler operated at pressures more than 1.03 bar (15 psig) (but not more than 20.68 bar (300 psig)) for steam, or for Medium Temperature Hot

Water (MTW) at pressures not exceeding 20.68 bar (300 psig) and temperatures not exceeding 176.6 degrees C (350 degrees F) for water. MTW pressure must exceed saturation pressure plus 1.72 bar (25 psig) to avoid cavitation.

## CHAPTER 2

### TYPES OF CONTROLS

2-1 **GENERAL.** Control systems may be pneumatic, analog, digital, or a combination of the three. Older designs utilized pneumatic control for local control loops. Analog control systems were an industry standard for a short time before quickly being replaced by digital control systems. The present industry standard is for a distributed control system (DCS), a programmable logic controller (PLC), or a direct digital controller (DDC) to provide digital control logic based on information gathered from electronic sensor inputs and responding with electronic control of pneumatic or electric powered valves and dampers.

2-2 **CONTROL SELECTION.** Choose the type of control that will do the job most economically. This includes total cost over the lifetime of the equipment. Also consider compatibility with controls used in the existing plant, ease of operation and maintenance, and plant personnel familiarity and training. Consider unique situations such as a high EMF (electric magnetic field) where either EMF shielding, fiber optic data transmission, or pneumatic controls are required. Obtaining the latest technology should not be used as the main criteria in the selection of controls.

Use the following as a guideline in selecting the type of control.

- Microprocessor digital type of controls (e.g. PLC, DDC, or DCS) should be used for most new designs and in particular where a large number of control loops are involved. Consideration should also be given to using microprocessor digital type controls to replace pneumatic control systems that have exceeded their life expectancy.
- Pneumatic control devices should be used in hazardous areas. They may also be used in the expansion of existing designs or as actuators for the final control elements in the design. In general, the pneumatic actuation of larger valves and large number of valves is more cost effective than using electric actuation.
- Analog logic devices (e.g. pneumatic receiver-controllers or electric potentiometer controllers) should not be considered for new designs.
- Consider the environmental conditions (e.g. temperature and humidity) in which the controls will be installed.

2-3 **PNEUMATIC CHARACTERISTICS.** Pneumatic characteristics are included primarily for the pneumatic power requirements of valves and dampers. In most cases, new designs should incorporate electronic control signals. Standard operating and supply pressures for pneumatic instruments are defined by ANSI/ISA-S7.0.01, *Quality Standard for Instrument Air*.

2-3.1 **Air Supply Pressure.** Plant and instrument air is typically available at 6.21 bar (90 psig) pressure. Instruments typically operate from a 1.38 bar (20 psig) supply. A standard pneumatic control signal is 0.21-1.03 bar (3-15 psig). Standard pressures

for diaphragm actuators are 1.03 and 2.07 bar (15 and 30 psig). Standard pressure for piston operators is 6.21 bar (90 psig).

2-3.2 **Design Considerations.** Piston operators are used for dampers and control valves. Size pneumatic devices operating on a nominal 6.21 bar (90 psig) air supply so that they will operate with a minimum pressure of 4.14 bar (60 psig) and will withstand a maximum pressure of 7.58 bar (110 psig).

2-3.3 **Service Tubing Size.** Use 9.53 millimeter (3/8-inch) outside diameter (OD) copper or stainless steel tubing for signal transmissions of 60.96 meter (200 feet) and over. For shorter lines, use 6.35 millimeter (1/4-inch) OD copper or stainless steel tubing.

2-3.4 **Control Distance.** Pneumatic control can be used for up to 60.96 meter (200 feet) without any special provisions and up to 91.44 meter (300 feet) if the valve has a positioner. A volume booster must be used for distances between 60.96 and 91.44 meters (200 and 300 feet) if the valve does not have a positioner. Use electronic signals for valve control in lieu of pneumatic for distances greater than 91.44 meter (300 feet).

2-3.5 **Instrument Air Regulation.** Furnish pneumatic instruments requiring an instrument air supply with individual combination filter-regulators and an output gauge. Instrument air should be supplied by an oilless compressor to help eliminate control instrument and device contamination.

## 2-4 ELECTRICAL CHARACTERISTICS.

2-4.1 **Electrical Interface.** The electrical interface between instruments and a digital controller varies depending upon application. Typical analog signal ranges and levels include the following:

- mA direct current (DC) (4-20 mA, 10-50 mA, or 0-100 mA)
- volts DC (0-10 millivolts, 0-100 millivolts, or 0-5 volts)
- temperature (thermocouple in millivolts, or RTD)
- volts alternating current (AC) (120 volts)

Transmitters and control valves commonly use a range of 4-20 mA DC. Switches and solenoid control commonly use a switched level of 120 volts AC. For signal requirements for instrument loops refer to ANSI/ISA-S50.1, *Compatibility of Analog Signals for Electronic Industrial Process Instruments*.

2-4.2 **Communication Data Bus.** Complex boiler control systems may involve multiple digital control systems (e.g. DCS, PLC, or computer controlled smart instruments) linked together by a communication data bus. The communication data bus passes significant data between the digital control systems in a serial format. There are numerous bus architectures available. One commonly used is the RS-485 hardware bus with Modbus software protocol. Refer to TIA/EIA-485, *Characteristics of*

*Generators & Receivers for Use in Balanced Digital Multipoint Systems* for a complete definition of the RS-485 bus. Modbus protocol is an open industry standard that was originally created and defined by the Modicon Company. Other industry communication bus standards include:

- Fieldbus -- A hardware and software protocol standard created and maintained by the Fieldbus Foundation. The Fieldbus Foundation is a not-for-profit organization that consists of more than 100 of the world's leading control and instrumentation suppliers and end users.
- DeviceNet -- A hardware and software protocol standard maintained by the Open DeviceNet Vendor Association (ODVA). The ODVA is an independent organization that works closely with vendor members, end users, and distributors to further establish DeviceNet as an open communications network in industry automation.
- HART -- An open hardware and software protocol standard that was originally created and defined by the Rosemount Company.
- Honeywell -- A family of proprietary hardware and software protocol standards (e.g. the D-E bus) that are licensed products of the Honeywell Company.
- Allen-Bradley-- A family of proprietary hardware and software protocol standards (e.g. the Data Highway + bus) that are licensed products of the Allen-Bradley Company.

## CHAPTER 3

### GENERAL REQUIREMENTS

3-1 **GENERAL.** Provide control systems in accordance with applicable codes. Refer to paragraph 3-15 for applicable codes. Design control systems so that the loss of the control medium (e.g. air, electricity, or other) will leave the controls in a fail-safe position.

3-2 **CONTROL LOCATION.** Locate instrument control in the control room as much as practical. Provide local control panels where they are required for equipment start-up and where constant attendance is not required.

3-3 **TURNDOWN.** Instruments have to cover normal operating as well as upset conditions. Several instruments might have to be provided to cover all of the ranges. It is important that all instruments be reviewed for covering all operating as well as upset conditions during the plant design stage.

3-4 **INSTRUMENT RANGES.** Size flow instruments based on a normal operating flow of approximately 70 percent of full scale. For all other instruments set the normal operating point at 50 percent of full scale. Use the following scales:

- Flow -- Direct reading
- Pressure -- Direct reading
- Temperature -- Direct reading
- Level -- 0-100% linear
- Analyzers -- Direct reading

Suppressed ranges for temperature and pressure may be used as long as they cover startup and upset conditions.

3-5 **ALARMS AND SHUTDOWNS.** Design the plant controls to avoid nuisance shutdowns. These can be caused by unnecessary items being interlocked into the shutdowns, bad design, or lack of provisions in the case of power or instrument air failure. Also design for easy restart in the case of shutdown, especially when caused by non-process type failures such as interruption of power or instrument air.

3-5.1 **Design Criteria.** Use contacts that open on abnormal conditions to alarm or shut down. For all shutdowns provide a pre-alarm that precedes the shutdown. Provide separate devices for alarms and shutdowns. Do not use the same device for an alarm or shutdown as used for control. An electrical power or instrument air failure must shut off all fuel and require operating personnel attention for a restart.

3-5.2 **Testing and Servicing.** Include provisions for the testing and servicing of the shutdown device and related alarms without interfering with plant operation.

3-5.3 **Interlock and Safety Requirements.** Safety controls are needed to protect against boiler explosions and implosions. Interlock and other safety requirements for boilers are given in the following American Society of Mechanical Engineers (ASME) and National Fire Protection Association (NFPA) standards. Where local or state code requirements differ from the ASME and NFPA codes, the more stringent code requirements must prevail.

- ASME CSD-1 *Controls and Safety Devices for Automatically Fired Boilers*
- NFPA-8501 *Standard for Single Burner Boiler Operation*
- NFPA-8502 *Standard for the Prevention of Furnace Explosions/Implosions in Multiple Burner Boilers*
- NFPA-8503 *Standard for Pulverized Fuel Systems*

3-5.3.1 **Safety Interlocks.** Safety interlocks are required but not limited to those listed below. Additional safety interlocks may be required to fulfill applicable state and local codes for the boiler fuel type used.

- Prepurge Interlock – Prevents fuel from being admitted to a furnace until the furnace has been thoroughly air-purged to remove residual combustibles.
- High Steam Pressure Interlock – Fuel is shutoff upon abnormally high boiler steam pressure.
- Low Airflow Interlock – Fuel is shutoff upon loss of airflow from the combustion air fan or blower, the induced draft fan or the forced draft fan.
- Low Fuel Supply Interlock—Fuel is shut off upon loss of fuel supply pressure. The loss of fuel supply pressure would result in unstable flame conditions.
- Loss of Flame Interlock – All fuel is shut off upon loss of flame in the furnace or to an individual burner in the furnace.
- Fan Interlock – Stop forced draft upon loss of induced draft fan.
- Low Water Interlock – Shut off fuel on low water level in boiler drum.
- High Combustibles Interlock (optional) – Shut off fuel on highly combustible content in the flue gases.
- Post Purge Interlock – Continues fan operations to remove residual combustibles from the furnace prior to shutting down the fans.

3-5.3.2 **Shutdown Valve Reset.** Safety shutoff valves must be a manual reset type and shall not be operable until all limit controls are in the safe position. Sequence interlocks for start-up and stop must also be provided. Provide annunciator alarms to respond to any safety shutdown.

3-5.3.3 **Dedicated Safety System.** The safety shutdown system must be dedicated and independent of the one used for boiler control. For example, if PLC controllers are



utilized, the design must contain a PLC for safety shutdown that is separate and independent of the one used for boiler control.

3-5.3.4 **Special Considerations.** Special attention should be maintained throughout the boiler design to prevent the following safety hazards.

- Equipment must be designed to protect against electrical shock from exposure to control power.
- Boiler control must assure a sufficient quantity and duration of pre-purge airflow through the boiler prior to ignition to prevent boiler explosions.
- Boiler control must assure a sufficient quantity and duration of post-purge airflow through the boiler during shutdown to prevent boiler explosions.
- Boiler control must assure a sufficient quantity of combustion air and prevent excessive fuel during boiler operation to prevent boiler explosions.
- Boiler control must limit the number of retries when igniting the boiler pilot. The industry standard is to allow three attempts at achieving pilot ignition prior to necessitating a boiler purge cycle.

3-6 **HARDWARE.** Hardware standards are defined by NEMA-ICS 2, *Standards for Industrial Control and System Controllers, Contractors, and Overload Relays Rated Not More Than 2000 Volts AC or 750 Volts DC.*

3-7 **EQUIPMENT RATING AND CLASSIFICATION.** Provide instruments that are rated for the environment. Electrical components must be designed for the anticipated temperature and humidity inside of the enclosure, fungus proofing where required, and vibration. Refer to NEMA-ICS 1.1, *Safety Guidelines for the Application, Installation, and Maintenance of Solid State Control* for additional information.

3-7.1 **Enclosures.** Enclosures must be certified by the National Electrical Manufacturers Association (NEMA) for the environment where they will be used. NEMA 4 enclosures must be used for outdoor locations. Use NEMA 4X enclosures in corrosive environments. A space heater is required where condensation of moisture is a problem.

Enclosure ratings are defined by NEMA-250, *Enclosures for Electrical Equipment (1000 Volts Maximum)*, and NEMA-ICS 6, *Enclosures for Industrial Controls and Systems*. Enclosure ratings are summarized in Table 3-1.

**Table 3-1. Enclosure Ratings**

TYPE	LOCATION	PROTECTION AGAINST OR USE
1	Indoors	Dirt
2	Indoors	Same as above plus splashing water
3	Outdoors	Dust, rain
3R	Outdoors	Rain
3S	Outdoors	Dust, rain, sleet
4	Outdoors	Dust, rain, sleet, hosing down with water or indoors
4X	Outdoors	Same as above plus corrosion resistant or indoors
5	Indoors	Dirt, dust
6	Outdoors	Dust, rain, sleet, hosing down with water, or indoors temporary submersion in water
6P	Outdoors	Same as above plus corrosion resistant or indoors and prolonged submersion in water
7	Indoors	Hazardous locations. Available for Class I, Groups A, B, C, and D
8	Indoors	Same as above except arcing contacts immersed in oil
9	Indoors	Hazardous locations. Available for Class II, Groups E and G
10	Indoors	Hazardous locations. Non-ventilated. Meets Mine Safety and Health Administration requirements
11	Indoors	Dirt, splashing water, corrosion resistant Indoors Dirt, dust, splashing water, dripping non-corrosive liquids
12K	Indoors	Same as above except with knockouts. No protection at knockouts.
13	Indoors	Dirt, splashing water, oil, or coolant.

**3-7.2 Hazardous Locations.** Hazardous locations are defined by NFPA-70, *National Electric Code*. Enclosures must be rated for the location in which they will be installed. Cost savings may be achieved by relocating an enclosure from a hazardous location to a non-hazardous one. A summary of hazardous area classifications follows.

**3-7.2.1 Class Definition**

- Class I - Gases and Vapors
- Class II - Combustible Dusts
- Class III - Easily Ignitable Fibers or Flyings

Classes I and II are applicable to boiler plants; class III is not.

**3-7.2.2 Division Definition**

- Division 1 - Normally hazardous
- Division 2 - Not normally hazardous

Division 1 is usually not applicable to boiler plants except for coal handling and fuel storage areas. Division 2 is often applicable.

**3-7.2.3 Group Definition**

- Group A - Acetylene
- Group B - Hydrogen and other gases of equivalent hazard
- Group C - Ethylene and other gases and vapors of equivalent hazard
- Group D - Natural gas, gasoline, other gases and vapors of equivalent hazard
- Group E - Metal dusts
- Group F - Coal dust
- Group G - Agricultural and plastic dusts

Groups A, B, C, E, and G are not applicable to boiler plants. Groups D and F are applicable.

**3-7.3 Special Considerations.** When specifying enclosures note the following:

**3-7.3.1 Maintenance.** Class I, Group D, Division 2 can be met by either providing an explosion proof enclosure or by providing a non-explosion proof enclosure and purging it with air. The non-explosion proof enclosure is less expensive (initial cost) but requires an air supply and more attention in that a constant air purge must be maintained. This long-term maintenance is expensive. Therefore, to keep maintenance to a minimum, specify the enclosure as explosion proof. Only exceptionally large equipment should be considered for a Class 1, Group D, Division 2 constant air-purge system, where the life

cycle cost of the special enclosure will clearly exceed the life cycle cost of maintenance of the air purge and the effort to provide continuous assurance of safe operation.

**3-7.3.2 Specification Completeness.** Include all requirements when specifying explosion-proof enclosures. For example, specify the enclosure as Class I, Group D explosion-proof, not just explosion-proof. An explosion proof enclosure is not necessarily dust tight or suited for an outdoor location. Therefore, both the explosion proof requirement and the weather or dust tight requirement must be specified to define the required enclosure.

**3-8 POWER SUPPLIES.** Furnish a power supply that provides clean power to the instruments. That is one that is free of disturbances and nuisance shutdowns. The manufacturer should be able to provide equipment specifications and recommend safeguards against severe power disturbances. Refer to NEMA ICS 1.1, *Safety Guidelines for the Application, Installation, and Maintenance of Solid State Control* for additional information. Include the following:

- Provide power supplies that enable the controls, including combustion safeguard systems and other control devices, to operate through an electric power interruption of 20 milliseconds without affecting the operation of the plant.
- Provide an uninterruptible power supply (UPS) system to keep the electronic instrumentation on line in case of a power interruption. The required time depends on the plant and instrumentation, but 30 minutes is often specified. The UPS system must provide a safe plant shutdown in case of a longer power outage. Small UPSs located inside of control panels should be equipped with ventilation fans to remove unwanted heat.
- Connect all trip circuits to the UPS system.

UPS system standards are defined by NEMA-PE 1, *Uninterruptible Power Systems*.

**3-9 INSTRUMENT AIR.** Provide clean, dry instrument air as defined by ANSI/ISA-S7.0.01, *Quality Standard for Instrument Air*. Test that the instrument air control circuits are free of leaks per the same standard.

**3-10 WIRING AND CONDUITS.** Wiring must conform to NFPA 70, *National Electric Code*. Run signal, thermocouple, and power wiring in separate conduits. Wiring for alarm, shutdown, and interlock circuits of the same voltage as the power wiring may be run in the same conduit as the power wiring.

Cable and thermocouple wire must conform to NEMA-WC55, *Instrumentation Cables and Thermocouple Wire*. Provide high point vents and low point drains for all conduits. Recommended practices for control centers are defined by ISA-RP60.8, *Electrical Guide for Control Centers*.

3-11 **INSTRUMENT TUBING AND PIPING.** Do not bring lines containing process fluids such as water and steam into the control room, control panels or control boards.

Keep pneumatic signals in and out of the control room to a minimum. Use electronic signals instead. Avoid pneumatic signals in controlled pressure sensitive areas. Certain pneumatic local instruments "bleed" air to their environment.

Use recommended practices for installation of piping and tubing in control centers as defined by ISA-RP60.9, *Piping for Control Centers*.

3-12 **IDENTIFICATION.** Identify all instruments and controls with a stainless steel metal tag permanently mounted on the instrument. Include the instrument number and service in the identification.

3-12.1 **Nameplates.** Provide nameplates for all panel instruments on both the front and the rear of the panel. Minimum front panel information must include instrument number, service, scale factors, and units. The rear of panel only requires the instrument number. Use recommended practices on panel nameplates as defined by ISA-RP60.6, *Nameplates, Labels and Tags for Control Centers*.

3-12.2 **Terminations.** Identify each electrical and tubing terminal with the instrument item number to which it connects. Tag and number all terminals and the ends of all wires. Identify all electrical conduits as to type of wiring (power, thermocouple, DC signals, or other).

3-12.3 **Instruments.** Identify all local instruments such as valves and switches with the item number of the instrument with which it operates.

3-13 **INSTRUMENT SPECIFICATION FORMS.** Use instrument specification forms when ordering instruments. Forms and specification checklists for a number of instruments are provided in ISA-S20, *Specification Forms for Process Measurement and Control Instruments, Primary Elements and Control Valves*. Obtain complete information on the instrument from the manufacturer before ordering. Sources of information include manufacturer catalogs, data sheets and other literature. Provide all data required for ordering the instrument. Specify all items including optional selections and deviations from the manufacturers standard.

3-14 **DRAWINGS.** Use standard symbols. For standard symbols, presentation, and terminology refer to the following industry standards.

- ANSI/ISA-S5.1, *Instrumentation Symbols and Identification*
- ISA-S5.3, *Graphic Symbols for Distributed Control/Shared Display Instrumentation, Logic and Computer Systems*
- ANSI/ISA-S5.4, *Instrument Loop Diagrams*

Provide control schematic diagrams, logic diagrams, and instrument loop diagrams.

3-15 **CODE REQUIREMENTS.** Where local or state code requirements differ from the ASME, ANSI, and NFPA codes, the more stringent code requirements shall prevail. The following codes apply.

- ASME, *Boiler and Pressure Vessel Code, Section I, Rules for the Construction of Power Boilers, and Section IV, Rules for the Construction of Heating Boilers*
- ASME B16.5, *Pipe Flanges and Flanged Fittings*
- ASME B31.1, *ASME Code for Pressure Piping Power Piping*
- NFPA-70, National Electric Code
- NFPA-8501, *Standard for Single Burner Boiler Operation*
- NFPA-8502, *Standard for the Prevention of Furnace Explosions/Implosions in Multiple Burner Boilers*
- NFPA-8503, *Standard for Pulverized Fuel System*
- State, Local, and Utility Boiler Codes

3-16 **STANDARDIZATION.** Standardize all instrumentation in the boiler plant. Specify that all like instruments, such as all control valves, be provided from the same manufacturer. Avoid having two control valves in identical service from two different manufacturers or from the same manufacturer but of two different model numbers.

3-16.1 **Multiple Manufacturers.** Multiple manufacturers are acceptable for different types of instruments. Instruments of the same type, however, must be standardized. For example, controllers can be obtained from one manufacturer, control valves from a second manufacturer, and pressure gauges from a third manufacturer.

3-16.2 **Packaged Equipment.** Packaged equipment, which is often furnished with instrumentation included, does not always lead to standardization. Buying the package manufacturers standard, however, might result in considerable cost savings. Even with packaged equipment, however, the instruments should conform to the plant standards whenever practical.

3-16.3 **Special Considerations.** Also standardize the following for the boiler plant.

3-16.3.1 **Signal Amplitude.** Use standard signals. These are 4-20 mA DC for transmitters and control valves, 120 volts AC for switches, and 0.21-1.03 bar (3-15 psig) for pneumatic signals.

3-16.3.2 **Connections.** Use standard types of connections and connection sizes. Avoid non-standard connections.

3-16.3.3 **Recorders.** Standardize on recording charts, recorder pens, lamps and similar items. Note that recorders from two different manufacturers most likely will require different chart paper and pens.

3-17      **ENVIRONMENTAL CONCERNS.** The Environmental Protection Agency (EPA) regulates the maximum allowed emissions from all external combustion sources including boilers. EPA-AP-42, *The Compilation of Air Pollutant Emission Factors* contains information associated with the types and quality of emissions and methods used to control them. Allowable emission limits varies by local and state regulations. Consult the Code of Federal Regulations, Title 40, *Protection of Environment* for regulated limitations and monitoring requirements. The following are the criteria pollutants associated with the burning of fuel for boilers.

- Particulate matter
- Sulfur Oxide
- Nitrogen Oxide
- Carbon Monoxide
- Organic Compounds

Some common methods of minimizing or reducing these emissions include:

- Flue Gas Recirculation
- Low No<sub>x</sub> Burners
- Wet Scrubber
- Cyclone Separators
- Selective and Nonselective Catalytic Reduction (SCR and NSCR)
- Electrostatic Precipitator (ESP)
- Baghouse

3-18      **SAFETY PLAN AND HAZOP STUDY.** Boiler controls must be included in the Safety Plan and Hazardous Operations (HAZOP) Study submitted by the boiler designer.

## CHAPTER 4

### PANEL INSTRUMENTS

4-1 **GENERAL.** This section covers instruments usually located on panels. Non-panel instruments, such as control valves, are covered in Chapter 5.

4-1.1 **Types of Control Panels.** Boiler plant panels include panels for boiler control, combustion safeguards, and the control of special equipment such as electrostatic precipitators.

4-1.2 **Panel Location.** Panels may be located either in a control room or locally. Both types of panels are covered in this section and are discussed below.

4-1.2.1 **Control Room Panels.** The control room is the preferred location for panels. Locate as much of the plant instrumentation in the control room as practical. The central location of panels will simplify both operation and maintenance. The control room is also usually cleaner, has better temperature and humidity control, and has less vibration than other plant locations. These conditions necessitate less stringent instrument enclosure requirements and the instruments will last longer.

4-1.2.2 **Local Panels.** Local panels are located in the vicinity of the equipment that they control. This can be either indoors or outdoors. The atmosphere can vary from clean to dusty or corrosive. Local panels should be minimized since more time and effort is required to access and monitor a large number of local panels than a centrally located one.

Restrict local panels to instrumentation that does not require continuous attention and is used extensively for start-up and shutdown of the local equipment. Locate the panel as close to the equipment as practical. Do not locate local panels in front of any access panels or inspection plates where an operator may interfere with boiler inspections or where an explosion may injure an operator.

Provide a panel designed for the environment. Furnish the panel with a rain hood for outdoor locations. Avoid local wall mounted panels which are mounted flush with the wall. These panels may allow wall condensate to enter. The panel should be a self-supporting box type if it is not mounted integrally with the local equipment.

4-1.3 **Layout.** Good panel layout requires experienced personnel in panel design and user drawing review. The layout depends on the type of instrumentation to be placed on the panel and how it will be operated. For best results both the user and the designer should agree on instrumentation arrangement on the various panels prior to start of panel fabrication. Once the panel is in fabrication changes are expensive and should be kept to a minimum.

Provide a minimum of 10 percent spare panel space for the future expansion of control room panels. Provide 1.52 to 1.83 meters (5 to 6 feet) access clearance



between the panel and the wall behind it when possible. Recommended practices on control room and panel layout are defined by ISA-RP60.3, *Human Engineering for Control Centers*.

4-1.4 **Construction.** The following applies to both control room and local panels.

4-1.4.1 **Electrical Components.** Use solid state logic. Do not use relay logic except where only a few logic steps are involved.

Use items that have a long life and do not have to be frequently replaced. A typical example is the use of neon bulbs instead of incandescent bulbs for indicator lights. The neon bulbs have a longer life.

4-1.4.2 **Displays.** Use displays that are readily visible to the operator. This might entail specifying LED instead of LCD, although LCD consumes less power.

4-1.4.3 **Lighting.** Provide switched vapor tight lights to illuminate the front of the panel. Provide additional switched lights to illuminate the inside of the panel enclosure.

4-1.4.4 **Service Outlets.** Provide ground fault interrupt (GFI) protected 120 VAC duplex outlets within each panel enclosure section. Locate outlets not more than 6 feet apart within each section.

4-1.4.5 **Steelwork.** Fabricate enclosure panels from 3.04 millimeter (11 gauge (0.1196-inch)) or 3.18 millimeter (1/8-inch) steel plate. Reinforce the panels as required for stiffness. Use 1.52 millimeter (16 gauge (0.0598-inch)) minimum steel plate for doors. Slightly bevel or round all exposed edges. Larger panels are usually fabricated in 3.05 to 3.66 meter (10 to 12 foot) long sections. Make all joints vertical. Horizontal panel joints are not acceptable. Use angle iron at each end of a section to make up vertical butt joints. Preassemble the complete panel in the shop to check for accurate alignment and surface matching. Panel joints passing through an instrument are not acceptable.

4-1.4.6 **Prefabrication.** Specify panels to be complete with all instruments installed, piped, and wired. The only actions that should be necessary to place the panel in service are to connect power, instrument signals, and instrument air supply.

## 4-2 INDIVIDUAL ITEM REQUIREMENTS

4-2.1 **Controllers.** Boilers use three types of controllers. These are digital (e.g. microprocessor or computer based), analog, and pneumatic. Use the following guidelines in selecting the type of controller to be used:

- Use the type of controller that is the most economical and reliable.
- For plants with many control loops use digital type of controllers.

- For the expansion of existing controls within a plant use the existing technology. This may be either digital, analog electronic, or pneumatic controllers.
- Use pneumatic controllers in hazardous areas.
- Avoid use of pneumatic controllers in the control room.
- When using digital control avoid depending on a single or a few control devices for the entire plant without having a backup. A redundant controller might not be required if only a single controller controls one loop. However, if a single controller controls a large number of loops then provide redundancy so that if the controller fails another controller will automatically take over.

4-2.1.1 **Process Controllers.** Process controllers use one or several of the following control modes:

- On-off
- Proportional
- Integral (also called reset)
- Derivative (also called rate)

Most digital controllers have all of the above control modes included. They are also usually provided with anti-reset windup. Analog and pneumatic controllers often do not include all three control modes or anti-reset windup.

4-2.1.1.1 **Control Modes.** In general, use the following control modes for the indicated control loop.

- Flow -- Use proportional plus integral.
- Level -- Use proportional plus integral.
- Pressure and Temperature -- Use proportional plus integral. Use proportional plus integral plus rate when the application requires a quick response time.

4-2.1.1.2 **Testing.** Recommended practices on tests to be conducted on digital controllers are defined by ISA-RP55.1, *Hardware Testing of Digital Process Computers*.

4-2.1.1.3 **Controls.** Provide a separate control station for each control loop when using digital controls. Locate critical controls on the front of the panel. Provide the following minimum controls.

- Automatic/manual selection
- Set point adjustment
- Output signal adjustment when on manual control
- Alarm setting

4-2.1.1.4 **Alarms.** Provide the following minimum alarms.

- Controller failure
- High-high alarm
- High alarm
- Low alarm
- Low-low alarm

4-2.1.1.5 **Displays.** Provide each control station with the following minimum displays.

- Process reading
- Set point
- Output signal
- Input signal
- Automatic/Manual indication
- Controller failure indication
- High-high alarm
- High alarm
- Low alarm
- Low-low alarm

4-2.1.1.6 **Features.** Provide the following features as a minimum.

- Proportional, integral and derivative control modes
- Anti-reset windup
- Automatic/manual and manual/automatic bumpless transfer
- Change configuration without shutting down the control loop
- Display configuration data without interfering with the operation of the controller.

4-2.1.1.7 **Failure Response.** Provide the following minimum actions on controller failure.

- The controller should switch to manual operation, hold its last output signal, and send out an alarm showing controller failure if a backup controller is not provided.
- The control should automatically switch over to the backup controller and send out an alarm showing controller failure if a backup controller is provided.

4-2.1.1.8 **Signal Interface.** Digital controllers do not always have dedicated contacts for alarms and shutdowns. If the contacts are not provided, specify a controller where dedicated contacts for each alarm and shutdown condition can be easily added using hardware obtainable from the controller manufacturer. Provide one set of single pole double throw (SPDT) contacts as a minimum.

4-2.1.2 **Programmable Logic Controllers.** Programmable logic controllers (PLCs) are usually programmed in the electrical ladder diagram format. Other formats are also used. When specifying PLCs include the following features.

- Provide a controller that can be programmed in the electrical ladder diagram format when many logic steps are involved.
- Include provisions so that the controller can be programmed and the program read without disturbing its operation.

4-2.1.3 **Controller Configuration.** Provide a controller that can be programmed in any of the following ways at the programmer's option.

- From the front of the controller if a separate controller is provided
- From a manual control station if a separate controller is not provided
- From a configuration device manually
- From a configuration device using stored information from a tape, computer disk, or other data storage device

Provide either a non-volatile memory or battery back-up for the controller so that the controller configuration memory is not lost due to a power outage.

4-2.2 **Recorders.** Keep recorders to a minimum. They constitute considerable expense in paper and pen replacement costs. If recorders are required then standardize them so as to keep paper and pen inventory costs to a minimum. Note that recorders from different manufacturers usually require different paper and pens.

The preferred method of recording data is on computer disks, tapes, or other data storage device. This data can later be viewed on a monitor, printed, or plotted.

4-2.3 **Totalizers.** Provide a 8-digit minimum totalizer. Provide a lock to inhibit the reset function of reset type totalizers.

Whenever practical, record the data on a computer disk, tape, or other permanent data storage device and use a computer program to add up the totals.

4-2.4 **Indicators.** Dedicated indicators are commonly used with pneumatic and analog type of control systems.

Do not specify a dedicated indicator except for critical items when using digital type control systems. Obtain non-critical information from a control station read-out or from a monitor.

4-2.5 **Status Lights.** Do not specify a dedicated status light except for critical items. When dedicated status lights are required, use neon rather than incandescent lights as much as practical. Neon lights have lower power consumption and longer life. Use "Push to Test" indicating/status lights to ensure lights are functioning properly.

Obtain the information from a control station read-out or from a monitor whenever practical instead of using status lights for digital type control systems.

4-2.6 **Annunciators.** Annunciator standards are defined by ANSI/ISA-S18.1, *Annunciator Sequences and Specifications*. Use common trouble alarms instead of dedicated alarms as much as practical. Provide both visual and audible alarms. Provide a dedicated alarm for critical items.

4-2.6.1 **Common Alarms.** Provide a dedicated window to contain the common trouble alarms. When possible, include on this display the specific item within the group that caused the alarm.

4-2.6.2 **Dedicated Alarms.** Provide a separate window that includes all dedicated alarms associated with an area. Typical dedicated alarms are summarized in Table 6-2.

4-2.6.3 **Annunciator Systems.** Include the following minimum items in an annunciator system.

- Solid-state electronic system with first-out sequence.
- Back-lighted windows.
- Acknowledge, test, and reset pushbuttons. Locate the pushbuttons outside of the annunciator cabinet so that the cabinet door does not have to be opened to depress the pushbuttons. Provide a separate audible signal device and separate pushbuttons for each annunciator system.

4-2.6.4 **Alarm Indications.** The alarm indication is controlled by the annunciator manufacturer. Typical indications for various fault conditions follow.

- Normal - Light off and audible alarm off
- Abnormal - Light flashing, audible alarm on
- Abnormal First Out - Same as above except flashing pattern is different to distinguish it as a first out.
- Acknowledge - Audible alarm off
- Other than first-out - Light steady
- First-out - Light flashing but pattern is different from prior to acknowledgment
- Return to Normal - Light off and audible alarm off

4-2.7 **Selector Switches.** Provide a minimum of SPDT contacts for selector switches. Clearly label all switch positions. Label unused positions as such. Use back-lighted switches for critical items in areas that are not well lit.

Momentary selector switches may be required to electrically sequence equipment to start on emergency diesel generator power following the loss of normal power. This is necessary so as not to overload the emergency power circuit with equipment that has selector switches maintained in the "Run" mode.

4-2.8 **Pushbuttons.** Use SPDT contacts as a minimum. Provide recessed or covered pushbuttons for shutdowns to guard against nuisance trips.

4-2.9 **Plant Control Stations.** Plant control stations, like panels, can be located either in a main control room or locally. The main control room is the preferred location. Restrict local plant control stations to equipment that require them for start-up or shutdown. In this case locate the control station as close to the equipment as practical.

A typical control station consists of a computer for processing and storing data, a monitor, a keyboard, and a printer. Each of these items is discussed below.

4-2.9.1 **Computers.** Furnish the computer with a power supply that provides power that is free of disturbances. The manufacturer should be able to provide power supply specifications and recommend safeguards against severe power disturbances.

4-2.9.1.1 **Control Limits.** Limit the ability of the computer to control the plant to those functions that can be safely controlled from the computer and in compliance with applicable codes. Provide an alarm connected to an annunciator to show computer malfunction.

4-2.9.1.2 **Data Overflow Alarm.** Provide computers that are used for logging data with an alarm connected to an annunciator to show the following.

- Data storage capacity is approaching full.
- Data storage capacity has been exceeded.

4-2.9.1.3 **Redundancy.** Provide a spare computer to automatically take over the logging of critical data in the event of primary computer malfunction.

4-2.9.2 **Monitors.** Cathode-ray tube (CRT) monitors are the most commonly used type. Others include LCD type and luminous gas plasma screen type. Provide a spare monitor that can be readily switched over to display critical data in the event that the primary monitor malfunctions.

4-2.9.3 **Keyboards.** Provide sealed-type keyboards to resist liquid spills. Keyboards can be either a standard type or a non-standard with specialized keys. Standard keyboards should be used as much as practical. Mistakes are more likely to be made using a non-standard keyboard than using a standard keyboard. Keyboard replacement is also more difficult with a non-standard type.

4-2.9.4 **Printers and Plotters.** Provide an alarm connected to an annunciator to show printer failure for printers receiving critical on-line data. Also provide a back-up printer to take over if the primary printer malfunctions.

4-2.10 **Data Logging.** Provide the following minimum data logging for digital type control systems. Print out this information automatically on a dedicated printer.

- Date, time, and device alarmed or shut down
- Identify first out
- Time alarm acknowledged
- Time for return to normal

Include year, day, hours, minutes, and seconds in the date and time. In first out, show the device to alarm first then the device to first shut down the equipment.

4-2.11 **Receiver Instruments.** These instruments include recorders, indicators, controllers and totalizers (also known as integrators). Each is covered separately in preceding paragraphs.

4-2.12 **Potentiometer Instruments.** These instruments include recorders, indicators, controllers and transmitters. Each is covered in a separate paragraph in chapters 4 and 5.

## CHAPTER 5

### LOCAL DEVICES AND INSTRUMENTATION

5-1 **GENERAL.** This chapter covers local instruments. Panel instruments are not included. Instruments that are usually located on panels, such as controllers, are covered in chapter 4.

Instruments should be located where they are accessible. Instruments that must be operated during the start-up or shutdown of equipment should be located as close to the equipment as practical. Some instruments must be accessed continuously for operation, others only during startup and shutdown. All instruments must be accessible for calibration and maintenance. Locate instruments using the following order of access preference.

- Grade
- Platform
- Stairs
- Ladder
- Portable ladder

#### 5-2 INDIVIDUAL ITEM REQUIREMENTS

5-2.1 **Valves.** This paragraph covers control valves, pressure regulators and solenoid valves. Each type is discussed below.

5-2.1.1 **Control Valves.** Common types of flow characteristics for control valves include quick opening, linear, and equal percentage. Control valves with equal percentage flow characteristics are specified for most applications. Control valves with linear flow characteristics are hard to tune at low flow and should be avoided. Select the flow characteristic to suit the application. Tolerance criteria for control valves are defined by ISA-S75.11, *Inherent Flow Characteristics and Rangeability of Control Valves*.

5-2.1.1.1 **Design Checklist.** There are many items to be considered in control valve selection. Checklists are provided in most manufacturer catalogs. Critical items that are sometimes overlooked include type of shutoff, shutoff pressure, line hydrotest pressure and controllability at turndown conditions. Review all pertinent sizing and selection information including accessories when selecting a control valve.

5-2.1.1.2 **Construction.** Use carbon steel body with stainless steel trim. Other materials may be specified when required by unique conditions.

5-2.1.1.3 **Sizing.** Size control valves to absorb 30 to 50 percent of the total system pressure drop.



5-2.1.1.4 **Maintenance.** Provide manual block and bypass valves around control valves where practical to allow for control valve removal and servicing while the system is operational. If a manual bypass is not provided then furnish the valve with a hand wheel.

5-2.1.1.5 **Location.** Locate control valves at grade where practical. Install the control valve near the operating equipment that has to be observed while in local manual control.

5-2.1.2 **Pressure Regulators.** Use self-actuated regulators only where the operating pressure is below 10.34 bar (150 psig) and where variations from the control point are acceptable. Use pilot-operated pressure regulators where the operating pressure is equal to or above 10.34 bar (150 psig), or where minimal variations from the control setpoint are acceptable.

5-2.1.3 **Solenoid Valves.** Common uses for solenoid valves in a boiler plant include the routing of instrument air to control devices and shutoff service.

Verify solenoid valve sizing to ensure that the valve or damper will open or close within the specified amount of time. Port size might have to be increased to ensure the proper actuation time.

Verify that the proper solenoid valve is used for the intended service. An example of a critical service application is a pilot gas shutoff solenoid valve. Most manufacturer catalogs include checklists on items to be specified. Critical items sometimes overlooked include type of fluid, shutoff and opening pressures, and line test pressure.

5-2.2 **Actuators.** Use spring-loaded diaphragm type actuators where practical. Springless operators and cylinder operators are acceptable only when spring-loaded diaphragm type actuators cannot provide the desired performance.

Select the actuator so that the valve or damper that it controls will fail safe. Fail safe is defined as lock in position or take a position (either open or closed) that will result in the least upset.

Furnish a pressure gauge to show diaphragm loading pressure on actuators that do not have a positioner. Furnish positioners for all automatically operated dampers. Furnish positioners for all control valves in critical service and where the variable, such as flow, has to be closely controlled. Specify that the positioner be furnished with the control valve or damper instead of separate procurement. Provide bypass switches and 3 pressure gauges (air supply, instrument loading, and diaphragm pressure) for all positioners.

5-2.3 **Current to Pneumatic Converters.** Control valves and dampers require current to pneumatic converters (I/Ps) for pneumatic actuators with electronic control signals. It is important that the I/P be matched to the valve or damper, as applicable.

To avoid possible mismatch have the I/P furnished with the valve or damper instead of separate procurement.

5-2.4 **Dampers.** Dampers can be operated either manually or by means of an actuator. This paragraph covers only actuator-operated dampers. Manually operated dampers are not included in this document.

Specify temperature, pressure, pressure drop, type of shutoff, materials, damper bearings, linkages, damper bearing and linkage lubrication, and other applicable data when selecting dampers.

Provide a hand wheel or lever so that the damper can be manually operated in case of damper actuator failure.

5-2.5 **Pressure Relief Valves.** Provide pressure relief valves in accordance with the applicable codes. Refer to paragraph 3-15 for applicable codes.

5-2.6 **Rupture Disks.** Use reverse buckling type rupture disks at the inlet of the relief valve in corrosive services.

5-2.7 **Level Instruments.** Provide level instruments in accordance with applicable codes. In general, provide separate vessel connections for each level instrument. Provide 12.7 millimeter ( $\frac{1}{2}$  -inch) minimum vent and drain valves with plugs for all level instruments.

5-2.7.1 **Gauge Glasses.** Complete coverage of total liquid range is not always required. Consult the applicable codes for requirements. Also consider all operating conditions and upsets. Provide gauge glasses to cover and overlap a minimum of 5.08 centimeters (2 inches) beyond the ranges of displacers and switches.

Gauge glasses should only cover the critical range zone such as high, low, and normal levels when the range is also covered by differential pressure type level transmitters.

Provide illuminators for transparent gauge glasses.

5-2.7.2 **Displacer.** Displacer type level instruments can be used for level ranges up to 1.52 meters (60 inches) of fluid height. Avoid use of internal displacers except for open tanks and sumps. Provide carbon steel body material with stainless steel trim as a minimum.

5-2.7.3 **Differential Pressure.** Use differential pressure type level instruments instead of displacer type level instruments for ranges over 1.52 meters (60 inches) of fluid height. They may also be used for ranges under 1.52 meters (60 inches).

5-2.7.4 **Capacitance Level.** Avoid the use of capacitance type level instruments in boiler plants.

**5-2.8 Flow Instruments.** The most commonly used flow element in boiler plants is the orifice plate. There are numerous other flow measuring devices that can be used depending on the application. In alphabetical order these include annubar flowmeters, coriolis type mass flowmeters, elbow meters, flow nozzles, magnetic flowmeters, pitot tubes, pitot-venturi tubes, positive displacement meters, rotameters, target meters, thermal-loss meters (also known as heat-loss meters), turbine meters, ultrasonic flowmeters, venturi tubes, vortex flowmeters, and wedge elements.

Use an orifice plate for most flow measurement applications unless a different type of flow element, such as a flow nozzle or a pitot tube, offers specific advantages. Reasons for using flow elements other than orifice plates include higher accuracy, shorter meter run, lower pressure drop and large line size.

**5-2.8.1 Meter Runs.** Flow disturbances as much as 100 pipe diameters upstream of the flow measuring element can affect the accuracy of the flow measurement. Meter run requirements, including pressure tap locations, depend on a number of items. These include type of flow element, beta ratio, and flow disturbances upstream and downstream of the flow element. Flow disturbances result from valves, elbows, enlargers, reducers, and other pipe fittings.

**5-2.8.1.1 Requirements.** Obtain complete meter run requirements from the flow measuring device manufacturer to insure accurate measurements. This includes pressure tap locations and other details such as pressure tap size.

**5-2.8.1.2 Straightening Vanes.** Avoid the use of straightening vanes due to their cost. Use them only when meter runs without them are not practical.

**5-2.8.1.3 Fabrication.** Do not fabricate meter runs in the field. Fabricate them in a shop qualified in that type of work. Include in the shop fabricated meter run at least 10 pipe diameters of upstream piping and 5 pipe diameters of downstream piping. Straight runs of piping required in addition to the above can be fabricated in the field.

**5-2.8.2 Orifice Plates.** Orifice plate types include concentric and eccentric, square edge, quadrant edge, segmental and annular. In general, use concentric, square-edge orifice plates except for the following.

- Use quadrant edge for orifice plates with a Reynolds number of less than 10,000 (based on pipe diameter).
- Do not use concentric orifice plates for horizontal runs flowing wet steam or gas, liquids containing solids, or liquids containing gas or vapor. All of the above will result in inaccurate measurements.
- Water in the wet steam and liquid in the wet gas can cause damming of the liquid. Solids in the liquid can settle out upstream of the orifice plate. As a first solution use a concentric, square-edge orifice plate but locate it in a vertical run with flow in the downward direction. If locating the orifice plate

in a horizontal run cannot be avoided then use a segmental or eccentric orifice plate.

- Use a concentric, square-edge orifice plate located in a vertical run with flow in the upward direction for liquids containing gas or vapor. Use a segmental or eccentric orifice plate with the opening at the top if locating the orifice plate in a horizontal run cannot be avoided.

5-2.8.2.1 **Design.** Meter runs should be a minimum pipe diameter of 5.08 centimeters (2 inches). Do not use an orifice bore diameter of less than 12.7 millimeters (0.5 inch) due to the possibility of plugging. Do not locate orifices where a liquid is subject to flashing.

Select the orifice plate maximum design flow and meter differential to give a scale reading of approximately 70 percent at normal flow. Use a meter differential of 2.54 meters (100 inches) of water unless not practical.

The orifice plate beta ratio should be between 0.25 and 0.70 and preferably between 0.4 and 0.6. The beta ratio must never be less than 0.20. Do not exceed a beta ratio of 0.70 for gases or steam and 0.75 for liquids.

5-2.8.2.2 **Mounting.** Mount the transmitter near the orifice flanges. Use flange taps whenever practical. Specify orifice flange and taps in accordance with ASME B16.36, *Orifice Flanges*. Flange taps are well suited for pipe sizes of 5.08 centimeters (2 inches) and larger. Provide meter taps at the top of the flange for gas service in horizontal lines. Provide meter taps on the sides of the flange for steam, vapor and liquid service in horizontal lines. Mount the meter below the orifice taps for liquid and steam service and above the orifice taps for gas service. Provide a separate three-valve type manifold for each meter. Provide condensate traps for both the high and low pressure sensing lines for steam and condensate service lines.

5-2.8.2.3 **Construction.** Use 304SS material as a minimum for the orifice plate. Provide an identification tab projecting beyond the orifice flange. Show the following minimum information on the tab.

- Actual measured orifice bore
- Pipe inside diameter
- Orifice plate material
- Orifice plate orientation to flow
- Type of fluid

5-2.8.3 **Flow Nozzles.** Use flow nozzles for applications where a higher accuracy is required than using orifice plates.

5-2.8.4 **Venturi Tubes.** Use venturi tubes for applications where higher accuracy, lower pressure drop and shorter meter run are required than using orifice plates or flow nozzles.

5-2.8.5 **Elbow Meters.** Elbow meters may be used for measuring relative flow rates and where absolute readings are not required. Elbow meters provide good repeatability and can be installed using an elbow in the regular piping.

5-2.8.6 **Pitot Tubes.** Use pitot tubes for large ducts where high accuracy and rangeability are not required and where pressure drops must be kept low.

5-2.8.7 **Rotameters.** Rotameters are used for flow measurement in small lines such as fuel oil and purge air. Use glass tube rotameters only for purge air. Otherwise use armored type rotameters.

Recommended practices on rotameters are defined by ISA-RP16.1, 2, 3, *Terminology, Dimensions and Safety Practices for Indicating Variable Area Meters (Rotameters, Glass Tube, Metal Tube, Extension Type Glass Tube)*, ISA-RP16.4, *Nomenclature and Terminology for Extension Type Variable Area Meters (Rotameters)*, and ISA-RP16.5, *Installation, Operation, Maintenance Instructions for Glass Tube Variable Area Meters (Rotameters)*.

5-2.8.8 **Magnetic Flowmeters.** Magnetic flowmeters provide obstructionless flow, good accuracy, and a good turndown ratio. They have the disadvantage, however, of being costly, large, and heavy.

5-2.8.9 **Positive Displacement Meters.** Use positive displacement meters only for high accuracy totalizing where measurement of flow rate is not required. These meters would typically be used for the measurement of fuel oil, fuel gas, and feedwater flow. Furnish a removable strainer installed upstream of the displacement meter.

5-2.8.10 **Turbine Meters.** Turbine meters are extremely accurate and have a high turndown ratio. They do, however, present a high pressure loss to the system. Refer to ISA-RP31.1, *Specification, Installation, and Calibration of Turbine Flowmeters* for additional information on turbine meters.

5-2.8.11 **Vortex Meters.** Vortex meters are extremely accurate, have a high turndown ratio, and present a low permanent pressure loss to the system.

5-2.8.12 **Annubar Meters.** An annubar meter is a rigid tube device that measures flow by producing a pressure drop signal that is proportional to the square of the flow rate. Multiple sensing ports along the tube average the velocity profile of the fluid. Meters of this type provide less permanent system pressure drop than orifice plates and can be used for all applications that involve clean fluids. Measurement accuracy and repeatability is good and turndown ratios of 4:1 to 11:1 can be achieved depending on meter tube design.

5-2.9 **Temperature Measurements.** Temperature instruments include thermocouples, resistance-temperature detectors (RTDs), filled bulb systems, and bimetallic thermometers.

5-2.9.1 **Thermowells.** Thermowells are used to protect the temperature element from the environment and for personnel protection. Thermowell design varies depending on the application. Items affecting design include temperature, pressure, type of fluid and fluid velocity. In general, thermowells can be classified into two types. These are pressure service and non-pressure service. Thermowells used in non-pressure service are commonly referred to as protective tubes.

Provide thermowells for all temperature elements in pressure service. Use 304 SS material as a minimum. Use the material best suited for the application of protective tubes.

5-2.9.2 **Thermocouples.** In general, use the following thermocouples for the different temperature ranges:

- Type T, Copper constantan -- Below -17.77 to 371 degrees C (0 to 700 degrees F)
- Type J, Iron constantan -- -17.77 to 593 degrees C (0 to 1,100 degrees F)
- Type K, Chromel alumel -- 315 to 1093 degrees C (600 to 2,000 degrees F)

Thermocouple assemblies can be single (one thermocouple) or duplex (two thermocouples). Provide duplex thermocouples for all temperature control loops. Use one thermocouple for control and the other for indication. Thermocouple and thermocouple extension wire specifications are defined in ANSI/ISA-MC96.1, *Temperature Measurement Thermocouples*, and NEMA-WC55, *Instrumentation Cable and Thermocouple Wire*.

5-2.9.3 **Resistance-Temperature Detectors.** Resistance-temperature detectors (RTDs) are used where accurate temperature or temperature difference measurements are required.

5-2.9.4 **Filled Bulb Systems.** Filled bulb systems are used for local temperature indicators, recorders, and controllers in services where the fluid temperature is below 426 degrees C (800 degrees F). Mercury filled bulb systems are not allowed. Provide armored capillary tubing for all filled bulb systems. Limit capillary length to 15.24 meters (50 feet) maximum. In all cases provide a thermowell where the filled bulb system is used in pressure service.

5-2.9.5 **Bimetallic Thermometers.** Bimetallic thermometers are mostly dial type thermometers used for local temperature indication. In all cases provide a thermowell where the bimetallic thermometer is used in pressure service.

5-2.10 **Pressure Measurements.** Pressure instruments include gauges, switches, and transmitters. In general pressure gauges use bourdon tubes to measure pressure greater than 1.03 bar (15 psig), and bellows to measure pressure less than 1.03 bar (15 psig) or differential pressure. Transmitters and switches use diaphragms to measure pressure. Use snubbers where pulsation dampening is required.

5-2.10.1 **Gauges.** Provide blowout discs for pressure gauges in services with pressures greater than 1.03 bar (15 psig). Provide a safety wall between the dial and the bourdon for service pressures above 68.9 bar (1000 psig). Provide pigtail siphons for all gauges in steam service. Pigtail siphons should be installed perpendicular to the gauge. Provide pulsation dampers and diaphragm seals where required by service conditions and for all gauges in steam and condensate service. Provide a gauge isolation valve for each gauge.

Pressure gauges are usually direct connected and field mounted. The size and range is specified by the user. Locate local gauges so that they are visible from the operating area and are readable from grade or a platform. Local mounted gauges give a "backup" reading and also help operators in determining if equipment or pressure systems are working satisfactorily. Pressure gauges should conform to ASME B40.100, *Pressure Gauges and Gauge Attachments*.

5-2.10.2 **Switches.** Pressure switches are used for monitoring alarm conditions and providing safety shutdowns. They are typically mounted directly to the process pipe.

5-2.10.3 **Transmitters.** Pressure transmitters convert the measured pressure to an analog or digital signal that is monitored by the control system (e.g. PLC). Provide a three-valve manifold to accomplish block, drain, and test functions for all pressure transmitters. Provide a five-valve manifold to accomplish block, equalize, drain, and test functions for all differential-pressure transmitters. Refer to paragraph 5-2.11 for additional transmitter requirements.

5-2.10.4 **Draft.** Pressure instruments for the measurement of draft in furnaces require careful attention as to range and sizing. Note that the draft in a balanced draft boiler furnace is slightly negative, around -2.54 millimeter (-0.1 inch) WC, at the top of the furnace. Too wide an instrument range will result in the loss of accuracy. Too narrow a range will not cover all operating conditions.

Verify that the connections and sensing lines are adequately sized for the low negative pressures. Use larger sizes than for lines sensing positive and high pressures.

5-2.11 **Electronic Transmitters.** Electronic transmitters are used to transmit an electronic signal from a local measuring device to a remotely located device such as a panel mounted controller. Typical transmitters include flow, level, pressure and flue gas oxygen. A typical electronic signal is 4-20 mA DC.

Use stainless steel material for all transmitter components in contact with the stream. Provide local indicators for all electronic transmitters. Locate the local indicator at the transmitter for non-controlling loops such as a signal to an indicator or recorder. Locate the local indicator at the controlling device for controlling loops such as diaphragm-operated valves. Provide an integrally mounted junction box with a metal cover and a terminal block for blind electronic transmitters to allow for the connection of a plug-in ammeter.

Electronic transmitters with internal microprocessors are known as “smart transmitters”. These transmitters provide on-board sensor linearization, data correction coefficients, measurement ranging, system diagnostics, and instrument configuration. These transmitters communicate to the control system via a communication bus (e.g. HART or Fieldbus).

**5-2.12 Electrical Instrument Switches.** Typical applications for electrical instrument switches are alarms and shutdowns. Contacts should open to alarm or shut down for fail safe operation. Provide switches that are suited for the environment. Provide switches that are dust tight and vibration proof for all locations. Provide NEMA 4 rated switches for outdoor locations with non-corrosive atmospheres and NEMA 4X rated switches for corrosive atmospheres. Provide SPDT contacts as a minimum.

**5-2.13 Analyzers.** Include all analyzers necessary to meet federal, state, and local environmental monitoring requirements. Analyzers used in a boiler plant include the following:

- In-line
- Sample diverted from the stream to the analyzer and then returned to the stream
- Sample diverted from the stream to the analyzer and then discharged to the atmosphere or a drain

**5-2.13.1 General Guidelines.** Use in-line analyzers where practical. As a second choice use an analyzer where the sample is diverted to the analyzer and then returned to the stream. Use an analyzer where the sample is discharged to the atmosphere or drain as a last choice. Provide a relatively constant differential pressure device, such as a pump, as a bypass to divert a sample that is to be returned to the stream. Avoid bypassing around a control valve.

**5-2.13.1.1 Calibration.** Where practical use a self-calibrating analyzer that provides zero and full span in the range in which the analyzer will be operating. Provide automatic calibration at power-up, at manual command, and at preprogrammed intervals.

**5-2.13.1.2 Application.** When to use analyzers and what type of analyzer to use depends upon environmental and value engineering concerns for a given boiler size. These issues are discussed in paragraph 3-17 and 6-4. Analyzers should be used for trim or alarms. Avoid using analyzers as a sole means of control or shutdown.

**5-2.13.1.3 Packaging.** It is possible to obtain multiple analyzers packaged in one system. For example, flue gas analyzers are available that combine oxygen, combustibles and methane measurement in one package. This packaging concept would reduce installation complexity and may provide cost savings.



When practical obtain the analyzer from the manufacturer completely packaged in a housing, wired, piped and with the sample system installed. Specify the analyzer to be free standing unless it is mounted on the equipment.

**5-2.13.2 Oxygen Analyzer.** Oxygen analyzers in a boiler plant are used for oxygen measurement to provide an indication of excess air in the flue gas. Use the analyzer for alarms and trim. Do not use it as the sole instrument for the control of combustion air.

Probe location is not critical for forced draft type or pressurized boilers since leakage is flue gas out of the boiler. Probe location is critical, however, for balanced draft boilers (which have induced draft fans), since leakage is typically tramp air into the boiler from flue ductwork. Locate the oxygen probe so as to keep the effect of tramp air on the oxygen reading at a minimum. This usually entails locating the probe as close to the furnace as practical.

**5-2.13.3 Combustibles Analyzer.** Combustibles analyzers in a boiler plant are used for carbon monoxide measurement, hydrogen measurement or both to provide an indication of incomplete combustion in the flue gas. Use the analyzer for alarms and trim. Do not use it as the sole instrument for the control of combustion air.

**5-2.13.3.1 Carbon Monoxide Analyzer.** Carbon monoxide (CO) analyzers used in a boiler plant may utilize a catalytic element, wet electrochemical cell, or non-dispersive infrared absorption.

Install the CO analyzer in a clean gas stream that is downstream of the particulate removal system.

A CO analyzer permits firing at lower oxygen levels than without it. A minimum air requirement is established by decreasing oxygen in the stack gas until a large increase in the CO reading occurs. A CO analyzer is also useful in boiler start-up. During start-up monitor the CO analyzer closely for unsafe firing conditions. High CO readings indicate incomplete combustion, which implies potentially unsafe conditions in the furnace.

**5-2.13.3.2 Hydrogen Analyzer.** Hydrogen (H<sub>2</sub>) analyzers used in a boiler plant are on line monitors that employ a catalytic element.

Like the CO analyzer, a Hydrogen analyzer permits firing at lower oxygen levels than without it. A minimum air requirement is established by decreasing oxygen in the stack gas until a large increase in the H<sub>2</sub> reading occurs. A H<sub>2</sub> analyzer is also useful in boiler start-up. During start-up monitor the H<sub>2</sub> analyzer closely for unsafe firing conditions. High H<sub>2</sub> readings indicate incomplete combustion, which implies potentially unsafe conditions in the furnace.

**5-2.13.4 Stack Opacity Analyzer.** Stack opacity analyzers are used in a boiler plant to monitor particulate emissions. Their main use is in coal and heavy oil fired boilers. Stack opacity monitors are generally not required for gas fired boilers, however, state

and federal regulations should be consulted. Also, most large boilers are dual fuel which may be a combination of gas and oil.

5-2.13.5 **Conductivity Analyzers.** Conductivity analyzers are used in boiler plants to monitor dissolved solids in the boiler drum. Use a conductivity analyzer for adjusting boiler blowdown. Do not use it as the sole device for boiler blowdown control.

5-2.13.6 **Methane Analyzers.** Methane analyzers in a boiler plant are used for methane measurement to provide an indication of a completed purge cycle prior to boiler ignition or during boiler shutdown. Note that this analyzer must be used in conjunction with and not as a substitute for the minimum purge time requirements stated in the applicable codes.

5-2.14 **Flame Detectors.** Provide the flame detector best suited for the fuel and flame. For gas fired boilers always use an ultraviolet (UV) self-checking flame scanner.

Do not use a flame detector that is activated by hot refractory.

Provide a separate flame detector for each burner. Locate the flame detector so that it will be activated only by its own burner and not by an adjacent burner or hot refractory.

5-2.15 **Continuous Emission Monitoring (CEM).** Provide all necessary equipment to meet federal, state, and local environmental analysis and documentation requirements.

## CHAPTER 6

### RECOMMENDED BOILER INSTRUMENTATION

**6-1 BOILER CONTROL PANEL INDICATORS, RECORDERS AND TOTALIZERS.** The instrumentation in Table 6-1 represents the minimum recommended requirements for a boiler plant. This instrumentation selection is based primarily on boiler operation safety concerns. Refer to NFPA 8502, *Standard for the Prevention of Furnace Explosions/Implosions in Multiple Burner Boilers* for further instrumentation concerns for boiler plants in the 13.18 gigajoule/h (12,500,000 Btu/h) or above range and ASME CSD-1, *Controls and Safety Devices for Automatically Fired Boilers* for boiler plants below 13.18 gigajoule/h (12,500,000 Btu/h). The indicators and recorders can be either dedicated or shared devices. Totalizers must be dedicated devices. Shared device selection may be either by means of pushbuttons, a selector switch, or by entering commands on a keyboard. Provide the following in the display of information associated with a shared device.

- Name of process variable
- Instrument number
- Units
- Process variable value

Store the process data in a storage device such as a computer disk or tape if a dedicated recorder or totalizer is not provided. Label the computer disk or tape as to process variable, instrument number, date, time, and units. The time label must include hours, minutes, and seconds. Store the data so that it can be retrieved selectively. In selective retrieval as a minimum include the name of process variable, instrument number, date and desired time interval. Include maximum and minimum points and alarms with the data to be recorded. Provide a dedicated printer or printer/plotter on which the recorded and totalized data can be presented on paper on demand. Data storage, retrieval, and printing must meet federal, state, and local environmental documentation requirements.

An instrumentation item is not applicable if the equipment that it services is not included in the plant. For example, if an air preheater is not provided then an air preheater outlet temperature indicator does not have to be furnished.

**6-2 BOILER CONTROL PANEL ALARMS AND SHUTDOWNS.** The alarms and shutdowns in Table 6-2 represents the minimum recommended requirements for a boiler plant. These were selected based primarily on boiler operation safety concerns. Refer to NFPA 8502, *Standard for the Prevention of Furnace Explosions/Implosions in Multiple Burner Boilers* for further information for boiler plants in the 13.18 gigajoule/h (12,500,000 Btu/h) or above range and ASME CSD-1, *Controls and Safety Devices for Automatically Fired Boilers* for boiler plants below 13.18 gigajoule/h (12,500,000 Btu/h). Provide a separate window in an annunciator system for each dedicated alarm. Provide a dedicated common trouble alarm window to which the non-dedicated alarms are wired. Include a first-out listing to show which device connected to the common trouble

alarm tripped first. Provide instrumentation to show which device shut the equipment down first during a system shutdown.

An alarm or shutdown is not applicable if the equipment that it services is not included in the plant. For example, if the boiler is gas fired only, a low fuel oil pressure alarm is not required. Refer also to paragraphs 3-5 and 4-2.6.

**6-3 BOILER CONTROL PANEL CONTROLLERS.** Provide controllers as required for the proper operation of the boiler plant. Controllers required for a typical boiler plant include steam header pressure (plant master and boiler master), boiler drum water level (feedwater flow), fuel flow, combustion air flow and boiler furnace draft.

**6-4 VALUE ENGINEERING.** There are many cost tradeoffs associated with the design of a boiler. The use of an oxygen trim system is one example. The installation of an oxygen trim system in a boiler design will provide fuel savings. The analyzer that provides this function, however, is costly to buy and maintain. Therefore, oxygen trim systems should only be used on large boilers where the cost of fuel savings outweighs the cost of the analyzer.

**Table 6-1. Boiler Control Panel Indicators, Recorders and Totalizers**  
(X shows instrumentation item required)

INSTRUMENT	INDICATOR	RECORDER	TOTALIZER
Levels			
Boiler drum water <sup>1</sup>	X	X	
Flows			
Boiler steam <sup>1</sup>	X	X	X
Boiler feedwater <sup>1</sup>	X	X	X
Combustion air <sup>1</sup>	X	X	
Fuel gas <sup>1</sup>	X	X	X
Fuel oil <sup>1</sup>	X	X	X
Pressures			
Boiler steam drum	X		
Steam outlet header	X	X	
Boiler feedwater	X		
FD fan outlet	X		
Pilot gas	X		
Fuel gas	X		
Fuel oil	X		
Atomizing steam	X		
Draft			
Boiler furnace	X	X	
ID fan inlet	X		
Differential pressures			
Air preheater air	X		
Air preheater flue gas	X		
Temperatures			
Steam			
Steam drum	X		
Superheater inlet	X	X	
Superheater outlet	X	X	
Steam header	X	X	
Feedwater			
Supply header	X	X	
Economizer inlet	X	X	
Economizer outlet	X	X	
Fuel oil	X	X	
Combustion air			
Air preheater inlet	X	X	
Air preheater outlet	X	X	
Flue gas			
Superheater outlet	X		
Boiler outlet	X		
Economizer inlet	X	X	

INSTRUMENT	INDICATOR	RECORDER	TOTALIZER
Economizer outlet	X	X	
Air preheater inlet	X	X	
Air preheater outlet	X	X	
ID fan inlet	X	X	
Flue gas stack	X	X	
Viscosity			
Fuel oil	X	X	
Flue gas oxygen <sup>1</sup>	X	X	
Stack opacity <sup>1</sup>	X	X	
Current in amps			
ID fan	X		
FD fan	X		

1. These records shall be maintained separately and not shared in storage.

**Table 6-2. Boiler Control Panel Alarms and Shutdowns**  
(X shows alarm or shutdown item required)

<b>INSTRUMENT</b>	<b>ALARMS</b>	<b>SHUTDOWNS</b>
Levels		
Boiler drum water		
Low	X	
Low-low	X	X
High	X	
High-high	X	X
Flows		
Combustion air		
Low	X	
Low-low	X	X
Pressures		
Boiler feedwater header		
Low	X	
Boiler steam drum		
Low	X	
Low-low	X	X
High	X	
High-high	X	X
Steam header		
Low	X	
High	X	
Pilot gas		
Low	X	
Low-low	X	X
High	X	
High-high	X	X
Fuel gas		
Low	X	
Low-low	X	X
High	X	
High-high	X	X
Fuel oil		
Low	X	
Low-low	X	X
High	X	
High-high	X	X
Atomizing steam		
Low	X	
Low-low	X	X

INSTRUMENT	ALARMS	SHUTDOWNS
High	X	
High-high	X	X
Atomizing air		
Low	X	
Low-low	X	X
High	X	
High-high	X	X
Instrument air		
Low	X	
Low-low	X	X
Scanner air		
Low	X	
Boiler furnace	X	
High	X	
High-high	X	X
Draft		
Boiler furnace		
High	X	
High-high	X	X
Differential pressure		
Atomizing steam to oil		
Low	X	
Low-low	X	X
Temperatures		
Boiler feedwater		
Low	X	
Fuel oil		
Low	X	
Low-low	X	X
High	X	
High-high	X	X
Flue gas		
Economizer outlet		
Low	X	
High	X	
Stack	X	
High	X	
High-high	X	X
Fan bearings		
High <sup>1</sup>	X	
Boiler water solids		
High	X	
Oxygen		
Low	X	



INSTRUMENT	ALARMS	SHUTDOWNS
High	X	
Smoke		
High	X	
Flame scanner failure	X	X
Failure to establish flame	X	X
Flame failure	X	X
Burner valves not closed		
Following trip	X	X
Equipment failure		
FD fan	X	X
ID fan	X	X
Oxygen analyzer	X	
Power failure		
Control	X	X
Equipment	X	X
Boiler shutdown		
Automatic	X	X
Manual	X	X

1. Provide one thermocouple at each bearing.

## CHAPTER 7

### CONTROL LOOPS

7-1 **GENERAL.** Provide controls in accordance with applicable codes. Refer to paragraph 3-15 for applicable codes. The codes take precedence over the control requirements shown in this handbook. A typical control loop is shown in Figure 7-1.

7-2 **CONTROL LOOP TYPES.** A single control loop includes a controlled variable sensor, controlled variable transmitter, controller, automatic-manual control station, and final control element. Control loops used for boilers may be of the pressure, temperature, liquid level type, or flow type.

7-2.1 **Pressure.** Pressure control loops may be used for the control of boiler pressure or fuel oil pressure. For the control of boiler pressure, the final control element regulates fuel flow to the boiler in response to boiler drum steam pressure. For the control of fuel oil pressure, the final control element is usually a pressure reducing control valve that regulates in response to downstream pressure. A typical pressure control loop is shown in Figure 7-2.

7-2.2 **Temperature.** Temperature control loops may be used for the control of steam temperature from boilers or fuel oil temperature from fuel oil heaters. A typical temperature control loop is shown in Figure 7-3.

7-2.3 **Level.** Liquid level control loops may be used for the control of boiler drum water level. A typical level control loop is shown in Figure 7-4.

7-2.4 **Flow.** Flow control loops may be used for the control of fuel flow into the boiler burners, burner draft airflow, feed water into a boiler, or steam flow out of a boiler. A typical flow control loop is shown in Figure 7-5.

7-3 **AIR TO FUEL-RATIO.** Furnish controls to automatically provide the proper fuel to air ratio over the entire boiler operating range from maximum turndown to Maximum Continuous Rating (MCR). Provide cross-limited (lead-lag) controls between air and fuel to increase airflow before increasing fuel flow and to decrease fuel flow before decreasing airflow.

Consider full metering controls, which measure directly both airflow and fuel flow, for all boilers with capacities greater than 5.28 gigajoule/h (5,000,000 Btu/h). Consider an oxygen analyzer, for trim only, for all boilers with capacities greater than 25.32 gigajoule/h (24,000,000 Btu/h). Consider CO trim for all boilers with capacities greater than 52.75 gigajoule/h (50,000,000 Btu/h), especially coal fired boilers. Evaluate the energy savings of these measures and provide all those that are life cycle cost effective per Executive Order 13123.

A typical cross-limited (lead-lag) boiler control system with oxygen trim for a single fuel is shown in Figure 7-6.

7-3.1 **Control Configuration.** Configure the controls so that the air to fuel ratio does not have to be manually reset or reprogrammed when switching from one fuel to another or from one combination of fuels to another. Provide an 8-point minimum fuel to air characterization curve for each fuel or combination of fuels. Provide controls so that the air to fuel ratio is automatically adjusted to the proper proportions for all of the following:

- Load change (between minimum firing and MCR)
- Fuel change (either change in fuels or same fuel but different specifications)
- Fuel ratio change (more than one fuel firing)

7-3.2 **Fuel Changeover.** Accomplish the switch over from one fuel to another without shutting down the boiler. Configure the controls so that the changeover from one fuel to another can be made by either a selector switch, pushbuttons, or by entering commands on a keyboard.

7-3.3 **Simultaneous Fuel Firing.** Provide automatic controls for maintaining the proper fuel ratio and fuel to air ratio to compensate for load changes when firing several fuels at the same time. Do not allow multiple attempts to switch fuels without a full post-purge and pre-purge after each unsuccessful fuel switch attempt.

7-3.4 **Alarms.** Furnish alarms to announce the approach of unsafe conditions. Provide shutdowns to shut the equipment down under unsafe conditions.

7-4 **BOILER DRUM LEVEL.** Provide controls to always maintain the boiler drum level within the boiler manufacturer's specifications under all operating conditions. Three types of control systems used in boiler plants are single element, two element and three element. These are shown in Figures 7-7, 7-8 and 7-9 respectively.

7-4.1 **Single Element Control.** A single element control system utilizes just a level transmitter to maintain control of the boiler drum water level. Use a single element control system only for boilers operating at steady loads.

7-4.2 **Two Element Control.** A two element control system utilizes a level transmitter and the amount of steam flow from the boiler to maintain control of the boiler drum water level. A two element control system provides some compensation for variable loads. It does not adequately correct for the expansion of water within a boiler due to the decreased boiler pressure that occurs when a large amount of steam is required or the contraction of heated water in a boiler due to the addition of cold feedwater. Do not use two element controls.

7-4.3 **Three Element Control.** A three element control system utilizes a level transmitter, the amount of steam flow from the boiler and the amount of water into the boiler to maintain control of the boiler drum water level. Note that although not shown, the steam flow from the boiler is usually compensated for pressure and temperature. A

three element control system corrects the problems associated with a two element control system and provides the best method of compensating for variable loads.

7-5        **MULTIPLE BOILERS.** The output of multiple boilers is accomplished by routing the steam from each individual boiler into a common plant output header. The pressure measured at this plant output header will be feed back into each individual boiler control loop. Control is maintained by the plant master cascading the output of the boiler masters to achieve the desired steam output. A typical multiple boiler control loop is shown in Figure 7-10. Dual Pressure Indicating Transmitters (PIT) and Pressure Indicating Controllers (PIC) are shown feeding their output signals into a High Select Relay. This redundancy may be provided for plants with three or more boilers to allow continued plant operations during maintenance or failure of one PIT or PIC.

Figure 7-1. Typical Control Loop

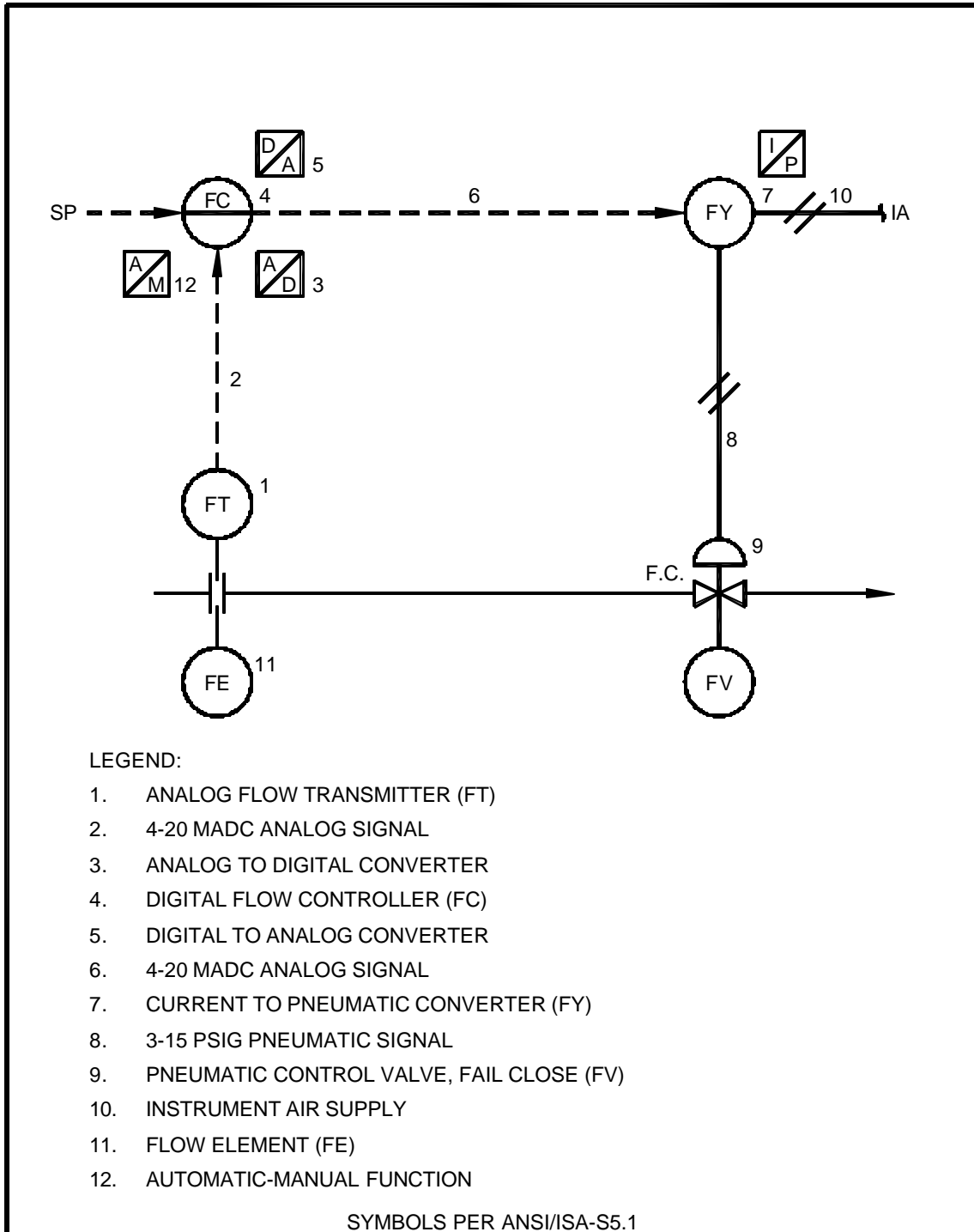

Figure 7-2. Typical Pressure Control Loop

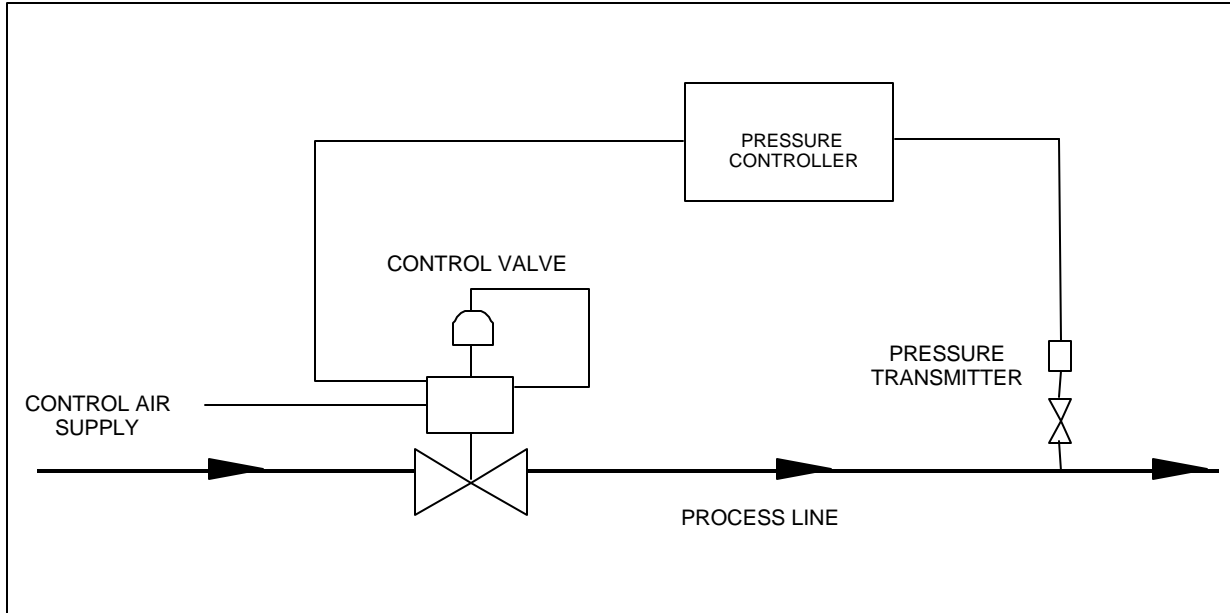

Figure 7-3. Typical Temperature Control Loop

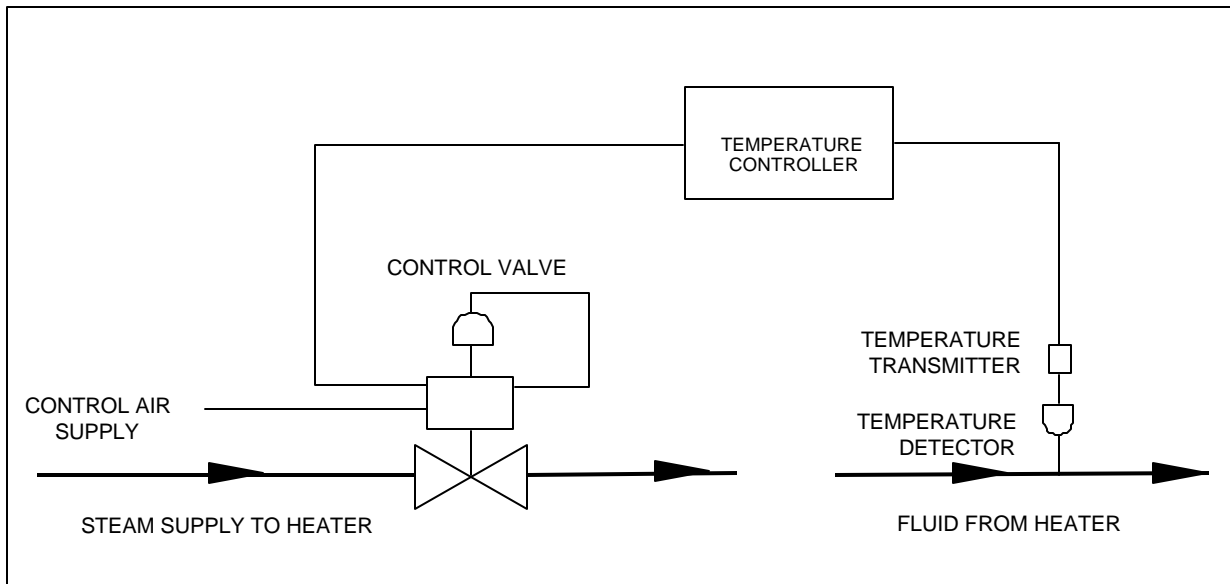

Figure 7-4. Typical Level Control Loop

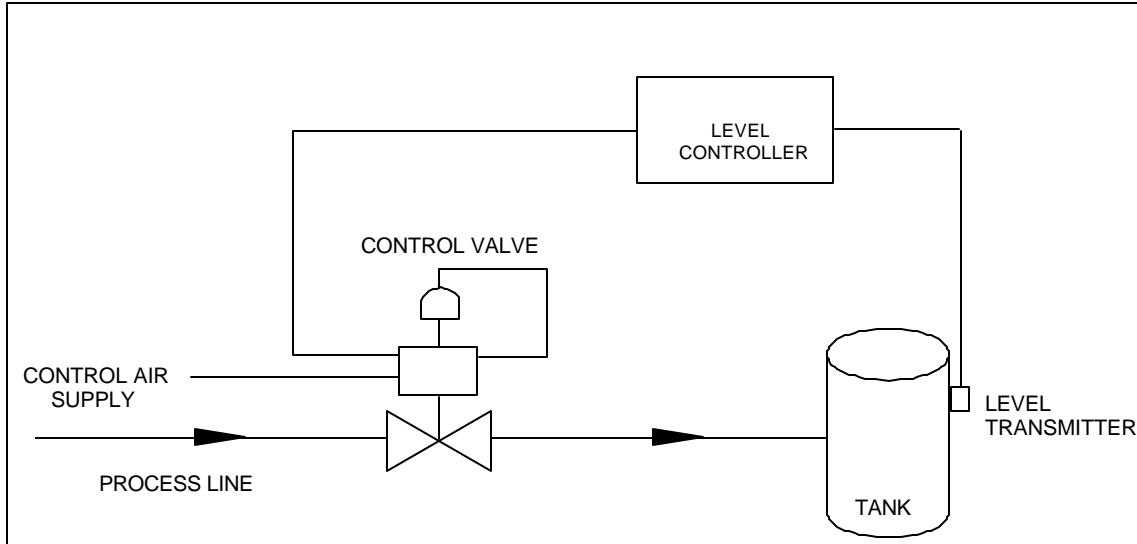

Figure 7-5. Typical Flow Control Loop

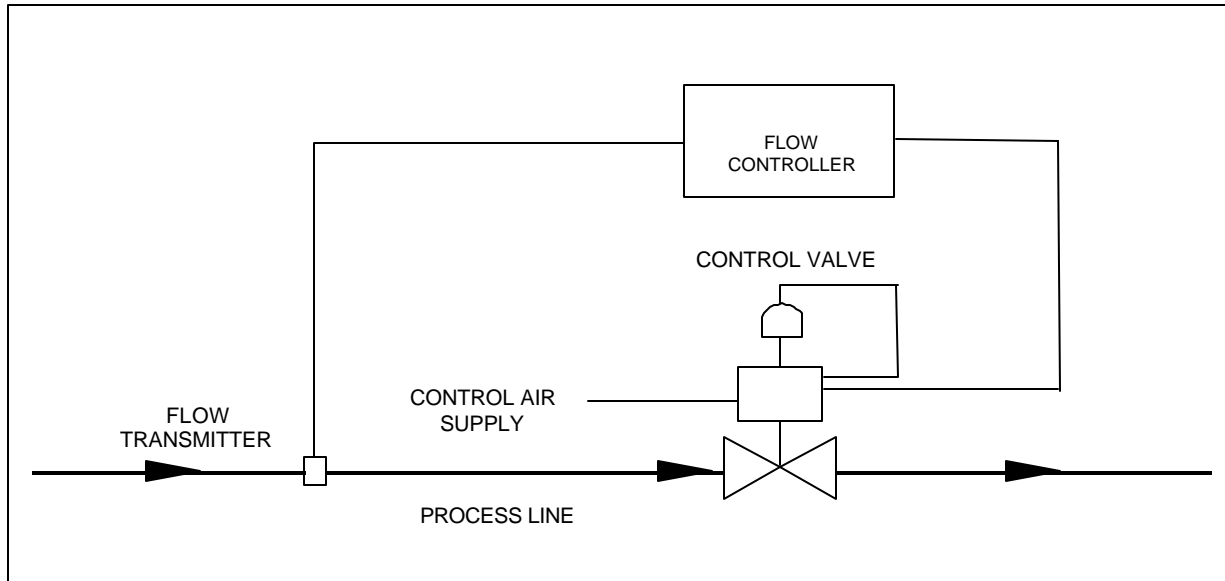

Figure 7-6.  
Typical Cross-Limited (Lead-Lag) Boiler Control System for a Single Fuel  
Using Full Metering with Oxygen Trim

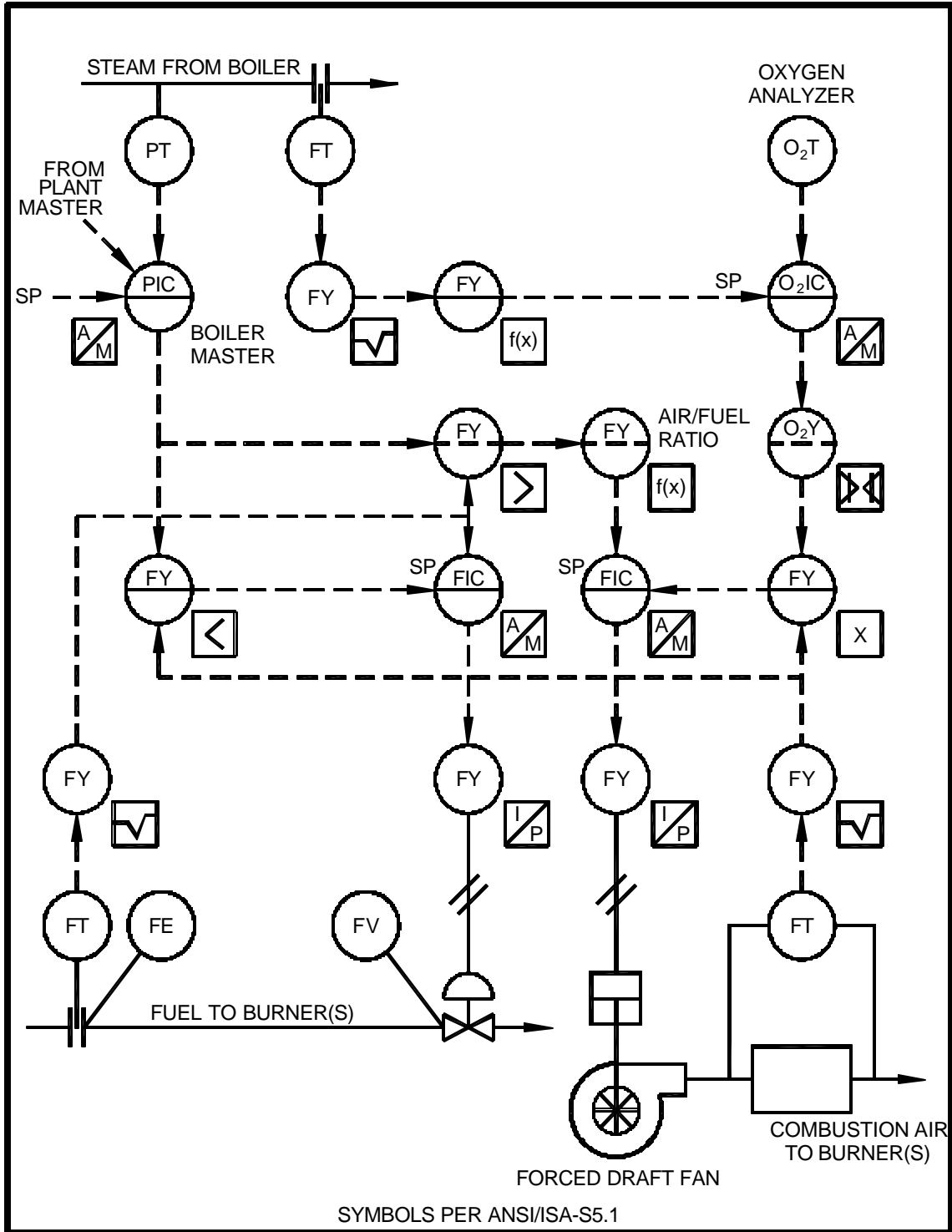



Figure 7-7. Single Element Drum Level Control System

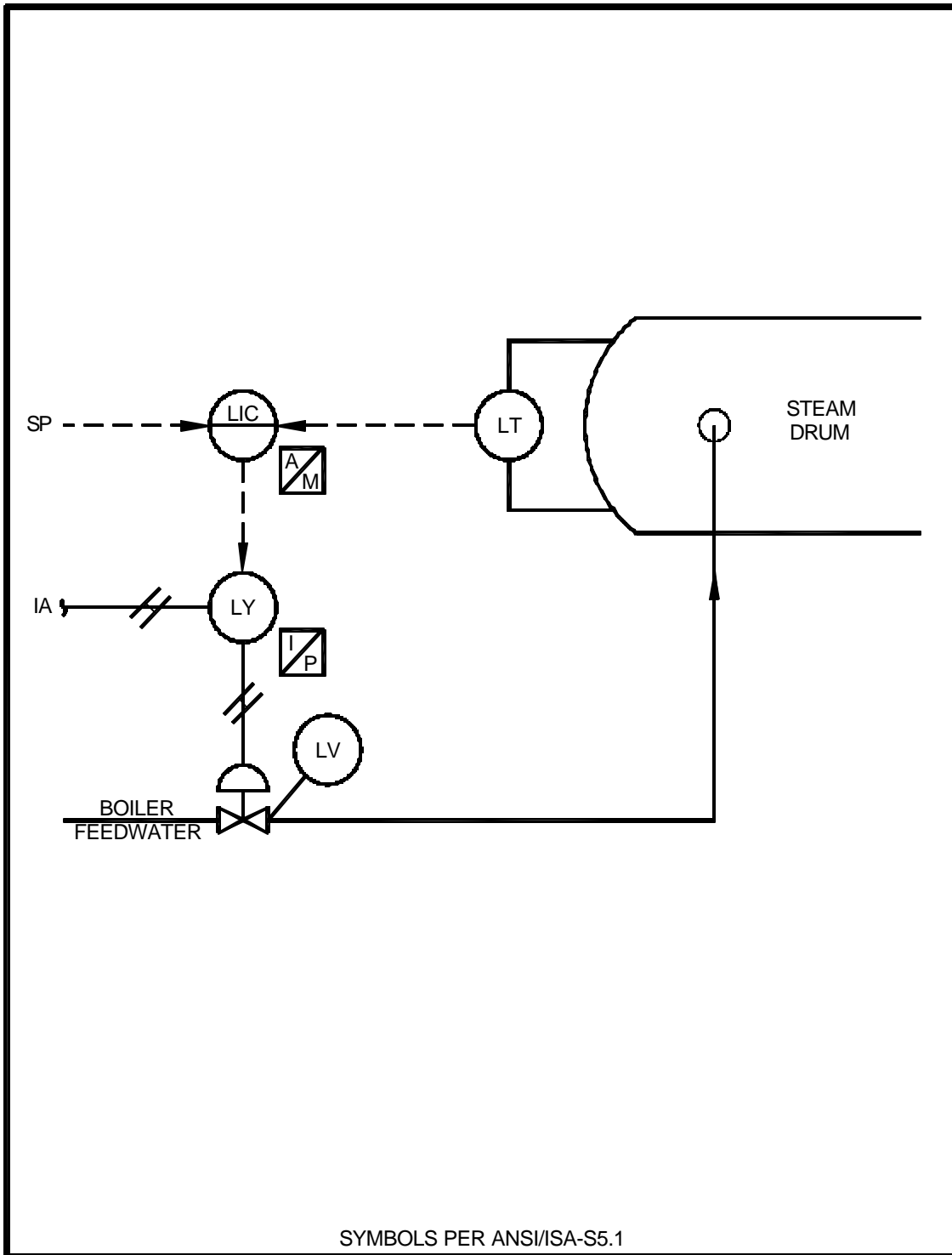

Figure 7-8. Two Element Drum Level Control System

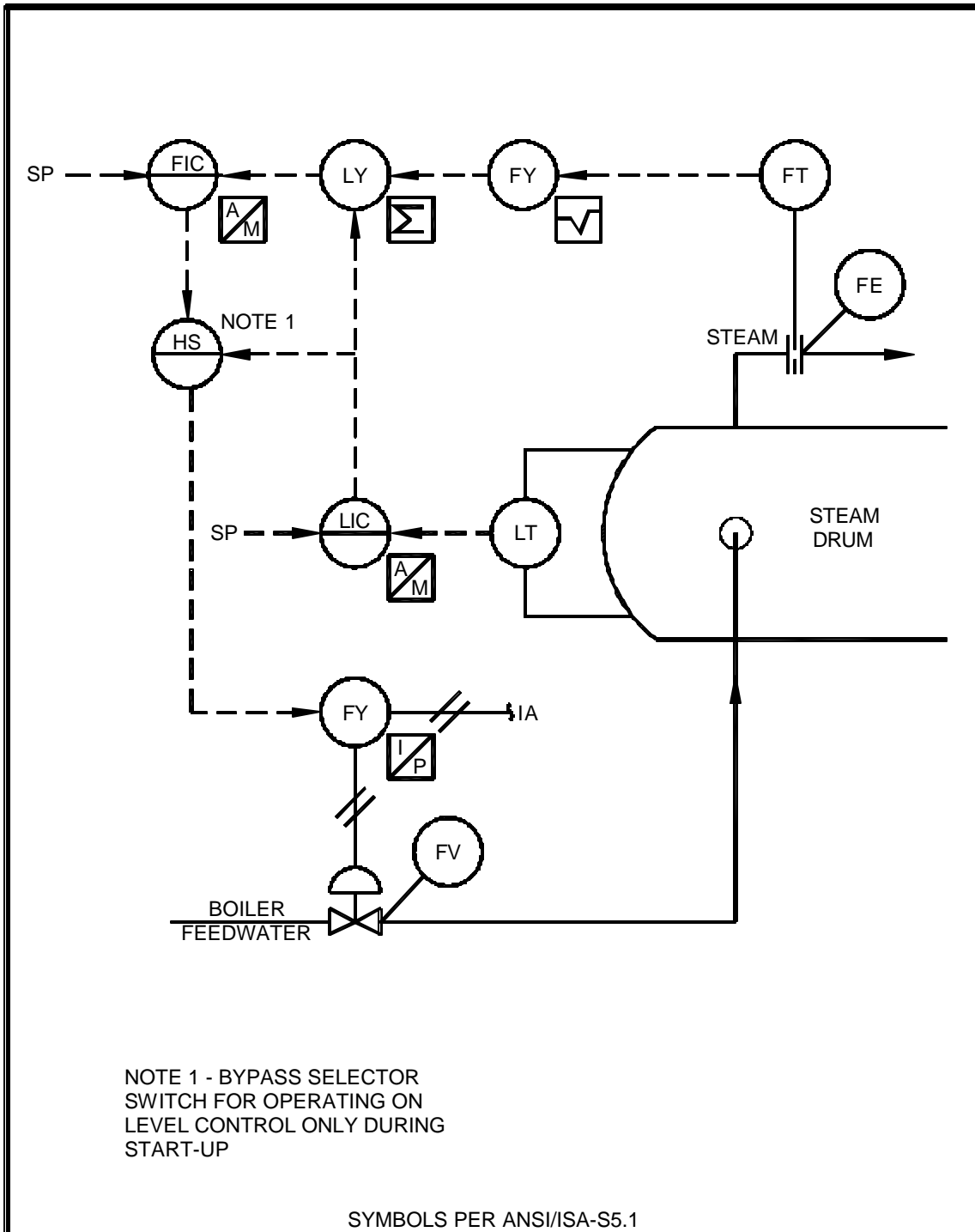

Figure 7-9. Three Element Drum Level Control System

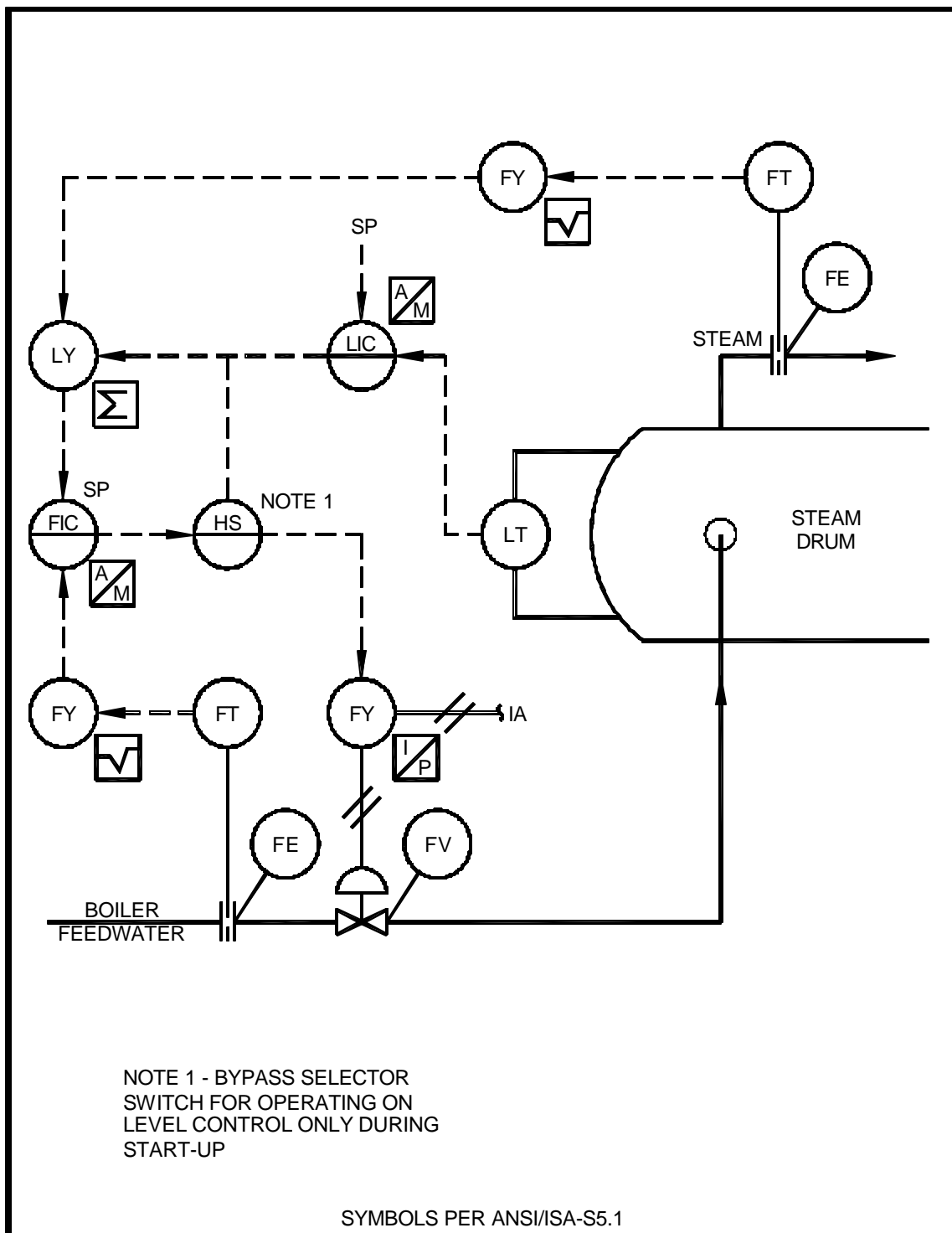
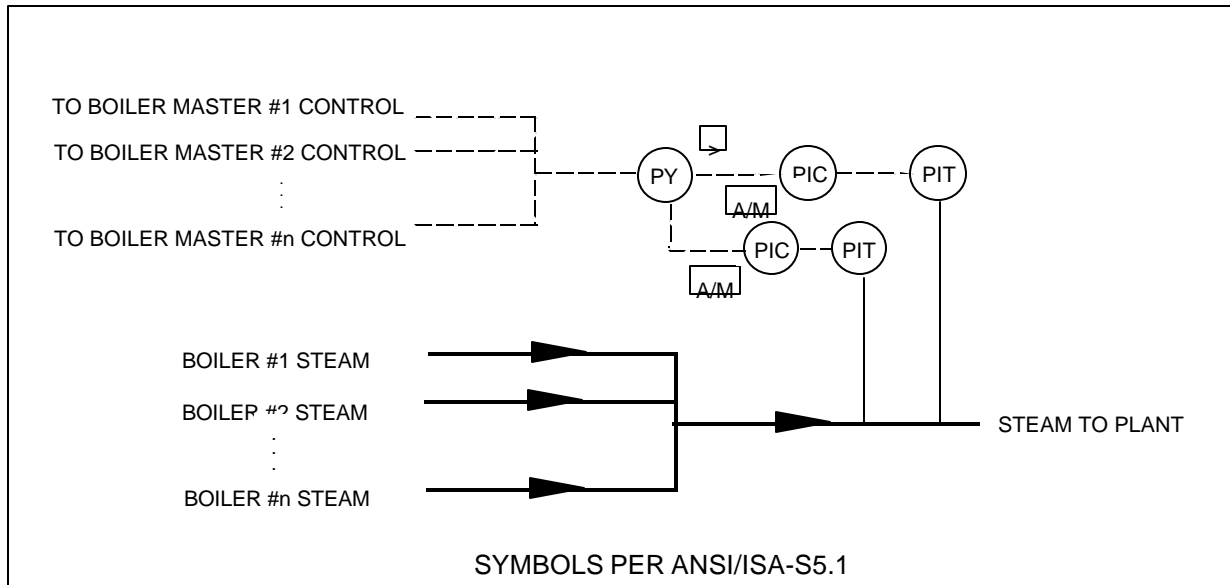

Figure 7-10. Multiple Boiler Control Loop – Plant Master



## APPENDIX A

### REFERENCES

#### GOVERNMENT PUBLICATIONS:

##### 1. U.S. GOVERNMENT PRINTING OFFICE

Superintendent of Documents  
U.S. Government Printing Office  
P.O. Box 371954  
Pittsburgh, PA 15250-7954

Environmental Protection Agency, AP-42,  
The Compilation of Air Pollutant Emission  
Factors

Code of Federal Regulations, Title 40,  
Protection of the Environment

#### NON-GOVERNMENT PUBLICATIONS:

##### 2. AMERICAN SOCIETY OF MECHANICAL ENGINEERS (ASME)

American Society for Testing and  
Materials  
1916 Race Street  
Philadelphia, PA 19103

ASME Boiler and Pressure Vessel Code,  
Section I, Rules for the Construction of  
Power Boilers and Section IV, Rules for  
the Construction of Heating Plants

ASME B16.5, Pipe Flanges and Flanged  
Fittings

ASME B16.36, Orifice Flanges

ASME B31.1, ASME Code for Pressure  
Piping, Power Piping

ASME B40.100, Pressure Gauges and  
Gauge Attachments

ASME CSD-1, Controls and Safety  
Devices for Automatically Fired Boilers

### 3. INSTRUMENT SOCIETY OF AMERICA (ISA)

Instrument Society of America  
P.O. Box 12277  
Research Triangle Park, NC 27709

ANSI/ISA-S5.1, Instrumentation Symbols  
and Identification

ISA-S5.3, Graphic Symbols for  
Distributed Control/Shared Display  
Instrumentation, Logic and Computer  
Systems

ANSI/ISA-S5.4, Instrument Loop  
Diagrams

ANSI/ISA-S7.0.01, Quality Standard for  
Instrument Air

ISA-RP16.1,2,3, Terminology,  
Dimensions and Safety Practices for  
Indicating Variable Area Meters  
(Rotameters, Glass Tube, Metal Tube,  
Extension Type Glass Tube)

ISA-RP16.4, Nomenclature and  
Terminology for Extension Type Variable  
Area Meters (Rotameters)

ISA-RP16.5, Installation, Operation,  
Maintenance Instructions for Glass Tube  
Variable Area Meters (Rotameters)

ANSI/ISA-S18.1, Annunciator  
Sequences and Specifications

ISA-S20, Specification Forms for  
Process Measurement and Control  
Instruments, Primary Elements and  
Control Valves

ISA-RP31.1, Specification, Installation,  
and Calibration of Turbine Flowmeters

ANSI/ISA-S50.1, Compatibility of Analog  
Signals for Electronic Industrial Process  
Instruments

ISA-RP55.1, Hardware Testing of Digital Process Computers

ISA-RP60.3, Human Engineering for Control Centers

ISA-RP60.6, Nameplates, Labels and Tags for Control Centers

ISA-RP60.8, Electrical Guide for Control Centers

ISA-RP60.9, Piping Guide for Control Centers

ISA-S75.11, Inherent Flow Characteristic and Rangeability of Control Valves

ANSI/MC96.1, Temperature Measurement Thermocouples

#### 4. NATIONAL ELECTRICAL MANUFACTURERS ASSOCIATION (NEMA)

National Electrical Manufacturers Association  
2101 L Street, N.W  
Washington, DC 20037

NEMA 250, Enclosures for Electrical Equipment (1000 Volts Maximum)

ICS 1.1, Safety Guidelines for the Application, Installation, and Maintenance of Solid State Control

ICS 2, Standards for Industrial Control and System Controllers, Contactors, and Overload Relays Rated Not More Than 2000 volts AC or 750 volts DC

ICS 6, Enclosures for Industrial Controls and Systems

PE 1, Uninterruptible Power Systems

WC 55, Instrumentation Cables and Thermocouple Wire

**5. NATIONAL FIRE PROTECTION ASSOCIATION (NFPA)**

National Fire Protection Association      NFPA-70, National Electrical Code  
Batterymarch Park  
Quincy, MA 02269

NFPA-8501, Standard for Single Burner  
Boiler Operation

NFPA-8502, Standard for the Prevention  
of Furnace Explosions/Implosions in  
Multiple Burner Boilers

NFPA-8503, Standard for Pulverized Fuel  
Systems

**6. ELECTRONIC INDUSTRIES ALLIANCE (EIA)**

Global Engineering Documents  
15 Inverness Way East  
Englewood, CO 80112

TIA/EIA-485, Characteristics of  
Generators & Receivers for Use in  
Balanced Digital Multipoint Systems