

# GPS Based Automatic Vehicle Tracking Using RFID

Devyani Bajaj, Neelesh Gupta  
neelesh.9826@gmail.com

**Abstract**— a vehicle tracking system is an electronic device installed in a vehicle to enable the owner or a third party to track the vehicle's location. The objects of the paper are: designing of a remote control vehicle having the facility of tracking location through GPS tracking & detection of object to avoid collision. If you want to know where your car or truck is, the routes and arrival time of your fleet of vehicle, if someone is abusing your vehicle or if you want to protect your vehicle from thieves, a vehicle tracking device can be of help.

**Index Terms**— GSM, GPS, GPRS.

## I. INTRODUCTION

Automatic Vehicle Location (AVL) is an advanced method used to track and monitor any remote vehicle equipped with a software unit that receives and transfers signals through GPS satellite. AVL is a combination of Global Positioning System (GPS) and Geographic Information System (GIS) that provides actual geographic real time position of each vehicle. The entire transmission mechanism of AVL setup depends on GPS satellite, a receiver on the vehicle, a radio system and PC based tracking software for dispatch. The radio communication system is generally the same as cellular phone network. The two most common AVL systems are like GPS based and Signpost based. The Signpost-based AVL system was used earlier but with the development of modern satellites GPS used technology is more used now. For the applications which require real time location information of the vehicle, Automatic Vehicle Location system is used that can transmit the location information in real time. Real time vehicular tracking system incorporates a hardware device installed in the vehicle (In-Vehicle Unit) and a remote Tracking server. The information is transmitted to Tracking server using RF transmitter if the distance between tracking sever and vehicle to be track is less. Tracking server also has RF receiver that receives vehicle location information and stores this information in database.



Fig.1. Automatic Vehicle Tracking

This paper is divided into main five parts. In the first part we are discussing the main principle of project i.e., GPS & RFID. In the second part the block diagram is explained. Working of the project is explained in third part with a brief explanation of each block. In the fourth part the last part gives the application and future aspect.

## II. LITERATURE REVIEW

Geolocation, position location and radiolocation are terms that are widely used today to indicate the ability to determine the location of an MS. Location usually implies the coordinates of the MS that may be in two or three dimensions, and usually include information such as the latitude and longitude where the MS is located. Vehicle tracking device is an outdoor geolocation application in which vehicle can be located using GPS while traveling on the road. Initially vehicle tracking systems developed for fleet management were passive tracking system. In passive tracking system a hardware device installed in the vehicle store GPS location, speed, heading and a trigger event such as key on/off, door open/closed. When vehicle returns to a specific location device is removed and data downloaded to computer. Passive systems also included auto download type that transfer data via wireless download but the system was not real time. [10, 11].

Passive systems weren't useful to track consumer's vehicle for theft prevention. Real time tracking system was required that can transmit the collected information about the vehicle after regular intervals or at least could transmit the information when required by monitoring station. Active systems were developed that transmit vehicle's data in real time via cellular or satellite networks to a remote computer or data centre. [10, 11]. Many vehicle systems that are in use now days are some form of Automatic Vehicle Location (AVL). It is a concept for determining the geographic location of a vehicle and transmitting this information to a remotely located server. The location is determined using GPS and transmission mechanism could be a satellite, terrestrial radio or cellular connection from the vehicle to a radio receiver, satellite or nearby cell tower. Other options for determining actual location, for example in environments where GPS illumination is poor, are dead reckoning, i.e. inertial navigation or active RFID systems or cooperative RTLS systems. After capture, the tracking data can be transmitted using any choice of telemetry or wireless communications systems. GSM is the most common used service for this purpose. [10, 11].

### III. GPS

Most modern vehicle tracking systems use Global Positioning System or GPS. The Global Positioning System is a global navigation satellite system developed by the United States Department of Defense and managed by the United States Air Force 50th Space Wing. Many systems also combine a communications component such as cellular or satellite transmitters to communicate the vehicles location to a remote user.

#### A. Working of GPS:

Global Positioning System satellites transmit signals to equipment on the ground. GPS receivers passively receive satellite signals; they do not transmit. GPS receivers require an unobstructed view of the sky, so they are used only outdoors and they often do not perform well within forested areas or near tall buildings. GPS operations depend on a very accurate time reference, which is provided by atomic clocks at the U.S. Naval Observatory. Each GPS satellite has atomic clocks on board.

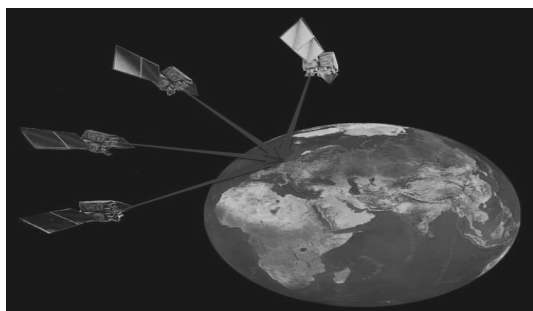

Fig.2. Signals from multiple satellites are required to calculate a position

Each GPS satellite transmits data that indicates its location and the current time. All GPS satellites synchronize operations so that these repeating signals are transmitted at the same instant. The signals, moving at the speed of light, arrive at a GPS receiver at slightly different times because some satellites are farther away than others. The distance to the GPS satellites can be determined by estimating the amount of time it takes for their signals to reach the receiver. When the receiver estimates the distance to at least four GPS satellites, it can calculate its position in three dimensions.

#### B. Determining Position through GPS:

A GPS receiver "knows" the location of the satellites, because that information is included in satellite transmissions. By estimating how far away a satellite is, the receiver also "knows" it is located somewhere on the surface of an imaginary sphere centered at the satellite. It then determines the sizes of several spheres, one for each satellite. The receiver is located where these spheres intersect. There are at least 24 operational GPS satellites at all times plus a number of spares. The satellites, operated by the US DoD, orbit with a period of 12 hours (two orbits per day) at a height of about 11,500 miles traveling at near 2,000mph. Ground stations are used to precisely track each satellite's orbit.

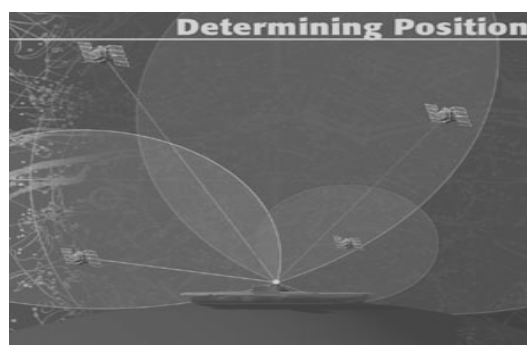

Fig.3. Determining Position through GPS

#### C. GPS Accuracy:

The accuracy of a position determined with GPS depends on the type of receiver. Most hand-held GPS units have about 10-20 meter accuracy. Other types of receivers use a method called Differential GPS (DGPS) to obtain much higher accuracy. DGPS requires an additional receiver fixed at a known location nearby. Observations made by the stationary receiver are used to correct positions recorded by the moving units, producing an accuracy greater than 1 meter. When the system was created, timing errors were inserted into GPS transmissions to limit the accuracy of non-military GPS receivers to about 100 meters. This part of GPS operations, called Selective Availability, was eliminated in May 2000.

#### D. Timing of signal:

All GPS satellites have several atomic clocks. The signal that is sent out is a random sequence, each part of which is different from every other, called pseudo-random code. This random sequence is repeated continuously. All GPS receivers know this sequence and repeat it internally. Therefore, satellites and the receivers must be in synch. The receiver picks up the satellite's transmission and compares the incoming signal to its own internal signal. By comparing how much the satellite signal is lagging, the travel time becomes known.

### IV. RADIO-FREQUENCY IDENTIFICATION (RFID)

RFID is a technology that uses communication through the use of radio waves to transfer data between a reader and an electronic tag attached to an object for the purpose of identification and tracking. RFID makes it possible to give each product in a grocery store its own unique identifying number, to provide assets, people, work in process, medical devices etc. all with individual unique identifiers - like the license plate on a car but for every item in the world. This is a vast improvement over paper and pencil tracking or bar code tracking that has been used since the 1970s. Furthermore, passive RFID tags (those without a battery) can be read if passed within close enough proximity to an RFID reader. It is not necessary to "show" the tag to the reader device, as with a bar code. In other words it does not require line of sight to "see" an RFID tag, the tag can be read inside a case, carton, box or other container, and unlike barcodes RFID tags can be read hundreds at a time. Bar codes can only read one at a time.

Some RFID tags can be read from several meters away and beyond the line of sight of the reader. The application of bulk reading enables an almost-parallel reading of tags.

Radio-frequency identification involves the hardware known as interrogators (also known as readers), and tags (also known as labels), as well as RFID software or RFID middleware. Most RFID tags contain at least two parts: one is an integrated circuit for storing and processing information, modulating and demodulating. A radio-frequency (RF) signal, and other specialized functions; the other is an antenna for receiving and transmitting the signal.[10] An RFID system is always made up of two components:

1. The transponder, which is located on the object to be identified,
2. The detector or reader, which, depending upon design and the technology used, may be a read or write/read device.

A reader typically contains a high frequency module (transmitter and receiver), a control unit and a coupling element to the transponder. In addition, many readers are fitted with an additional interface (RS 232, RS 485, ...) to enable it to forward the data received to another system (PC, robot control system, ...). The transponder, which represents the actual data carrying device of an RFID system, normally consists of a coupling element and an electronic microchip. When the transponder, which does not usually possess its own voltage supply (battery), is not within the response range of a reader it is totally passive. The transponder is only activated when it is within the response range of a reader. The power required to activate the transponder is supplied to the transponder through the coupling unit (contactless) as is the timing pulse and data [10].

## V. BLOCK DIAGRAM AND FUNCTION

### A. Objective:

1. Exploring GPS based tracking systems.
2. Developing Automatic Vehicle Location system using GPS for positioning information and GSM/GPRS/RFID for information transmission.
3. Acquisition of vehicle's location information (latitude longitude) after specified time interval.
4. Developing a web based software to display all transmitted information to end user along with displaying location of vehicle on a map.

In-vehicle unit is also responsible for transmitting this information to Tracking Server located anywhere in the world. To achieve all these functionalities In-Vehicle unit uses several modules as described below.

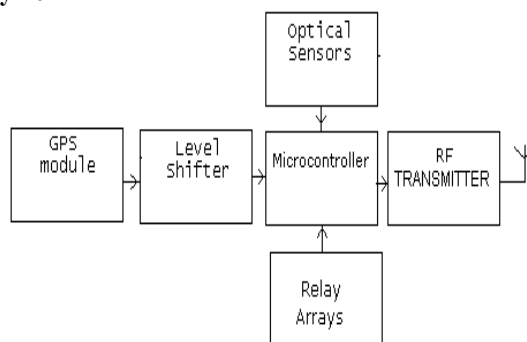

**Fig.4. Transmitter of GPS based Automatic Vehicle Tracking & Controlling Device**

### B. Function of Transmitter:

Fig. 4 shows the block diagram of transmitter section. Vehicle tracking systems are electronic devices installed in vehicles for tracking the exact location of the vehicle with the help of Global Positioning System (GSM). The mechanism of the AVL depends on satellite, radio system, GPS unit of the vehicle and a communication center that helps in the information management between dispatch station and customer or passenger.

#### Micro controller

As the name indicates this unit has the over all command of all blocks or this unit decides when to use & which unit has to be used. Since it is a programmable device it provides the facility to update the device without changes in hardware & it also reduces the hardware required to implement the circuit.

#### Relays Array

The vehicle is moved by motor, which required large current, but the micro controller cannot provide that much current. Hence to control the large currents by the pulses provided by micro controller for motor & this is done by using relays.

#### R.F. transmitter

For communication radio frequency can be used hence R.F. transmitter is required. Here we use the transmitter transmitting at 315 MHz using the OOK technique.

#### GPS Satellite

This locates the vehicle by sending satellite signals to the GPS modem of attached in the vehicle.

#### Vehicle GPS Unit

The GPS unit of the vehicle receives signals from the satellite, determines the geographic location or co-ordinates of the place and then transmits them to a radio station.

#### Radio System

It receives the vehicle's geo location coordinates via radio signals and transmits them to the principal communication center via radio signals.

#### Principal communication center

Collects the data from radio system and converts the vehicle information by using Internet or some specialized software. Then it sends the vehicle information to other information management stations including fleet management center and customer assistance and schedule management center.

### C. Function of GPS Receiver:

Fig. 5 shows the block diagram of Receiver section. In-Vehicle unit uses GPS receiver to capture the current location. Location provided by GPS is not in human understandable format. This raw data needs to be processed to convert it into useful information that can be displayed by a beacon on the map. CPU is required to process this raw data. SiRF Star III single-chip GPS receiver can be used which comes integrated with GM862- GPS which is GSM/GPRS modem used for data transmission. GPS receiver can also provide information of altitude, time of GPS fix, status of GPS fix, and number of satellite used to compute current location information along with location. GPS fix means last reported location. For tracking purpose only location data is required for transmission. Other data provided by GPS receiver is used to determine the validity of location information.

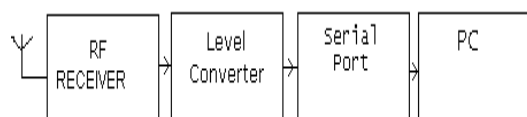

Fig.5. Receiver of GPS based Automatic Vehicle Tracking & Controlling Device

#### Level Converter

Serial port of pc can be used, which follows the RS232 standard hence we use a Level Converter. The first level converter converts the TTL signals in to RS232 signals & second level converter converts the RS232 signals to TTL signals.

#### PC Port

This is the part of unit through which unit interacts with PC, serial port is used for this purpose because we get serial data at the output of the level converter also because this port is TTL compatible.

#### R.F. receiver

It receives the R.F. signals & receiver is tuned to demodulate the 315MHz signals.

#### Central Processing Unit-

The raw data provided by the GPS receiver is captured by the CPU and processed to extract the required location. CPU is also responsible for monitoring the obstacle comes in the path of vehicle. CPU holds all the required information that is to be transmitted to remote server (i.e, RF Receiver). It also controls data transmission module to exchange information with remote server. It actually acts as a bridge between GPS receiver, vehicle and remote server. It receives commands sent by server through data transmission/receiving module and performs corresponding action required by server. As the processing required in the In-vehicle unit is not computationally intensive therefore any low end microcontroller can be used as a CPU. The microcontroller selected to serve as CPU for In-vehicle unit is Microchip's PIC18F248. This is 8-bit microcontroller and runs at speed of 20 MHz which is enough speed for the system.

#### Data Transceiver-

When all required information is extracted and processed, it needs to be transmitted to a remote Tracking Server which

will be able to display this information to the end user. For real time tracking of vehicle, reliable data transmission to remote server is very important. Wireless network is required to transmit vehicle information to remote server. Existing GSM or RFID network is selected to transmit vehicle information to remote server. Mostly GSM is used because of broad coverage of GSM network. It is also cost effective rather than to deploy own network for transmission of vehicle information. For data transmission over GSM network GSM modem is required. GSM modem can send and receive data SMS text messages and GPRS data over GSM network. GM862-GPS GSM/GPRS modem is selected to transmit data over GSM network because of its features and capabilities. GM862-GPS provides AT commands interface i.e. all functions can be accessed by use of AT commands. AT commands can be sent to it using serial interface. It has built in UART that accepts the AT commands and modem performs the function as required by AT command received.

GPS antenna receives signals from GPS satellites and it must face towards sky for correct computation of the current location by GPS receiver. Location data is transferred to microcontroller through serial interface. After processing of the data provided by GPS receiver, microcontroller transmits this information to remote location using RFID or GSM/GPRS modem. Microcontroller controls the operation of RFID or GSM/GPRS modem through serial interface using AT commands. If GSM/GPRS Modem is used then External GSM antenna is required by the GSM/GPRS modem for reliable transmission and receiving of data. When modem receives any command sent by tracking server, it passes this information to microcontroller which analyses received information and performs action accordingly.

## VI. APPLICATIONS

These days, growing thefts and malicious activities of vehicles are causing losses of billions across the world. Therefore, installing GPS in both commercial as well as private vehicles is the need of hour. Currently In-Vehicle unit was implemented with two boards. Microcontroller board was externally connected to GM862-GPS interface board. Single board can be designed to incorporate Microcontroller circuitry on the GM862-GPS interface board. It will reduce the overall size of In-Vehicle unit and it will also reduce the number of components so will the cost.

1. After installing a vehicle tracking device in an automobile, a person may easily locate the exact position of that vehicle along with its speed and mileage. Vehicle tracking device also helps the cops in finding stolen vehicles. Certain advanced vehicle tracking devices even deactivate the engine of the vehicle, thus disabling the vehicle from moving.
2. Moreover, parents may always monitor their kids on their journey, thus alerting the driver, that he or she is being watched. Therefore, considering all the safety aspects, a GPS auto tracking device is a necessity in almost every vehicle.

3. Moreover, a GPS vehicle tracking system displays the photograph of the driver driving the vehicle. GPS auto tracking system is very common in the U.S. and is rapidly becoming popular around the world.
4. Moreover, a vehicle tracking device can directly be connected with the personal mobile phone. In case of thefts or any other damages caused to the vehicle, a vehicle GPS tracking device immediately sends an alarm to the mobile for quick action.
5. The best quality of GPS tracking solutions is that, when an individual parks the vehicle in a parking lot and happens to misplace it, then just a phone call to the GPS customer service department will activate an alarm by making the lights flash, thus helping in finding the vehicle. Therefore, GPS tracking solutions help in locating the vehicle, save fuel by warning the drivers from over speeding and avoiding heading in wrong direction, controlling speed of vehicle, controlling Door open/close, Ignition on/off controlling.

#### VII. ADVANTAGES

The adaptation of AVL system brought a big difference in the productivity of almost all sectors.

1. **Increase in productivity** - Knowing the precise location of any vehicle help in the better management and that in turn makes positive financial impact on the organization. Better schedule or planning increases the average vehicle trips per day thereby saving capital and labor cost.
2. **Information & Communication** – Quality communication or information transformation helps in effective supervising in managing schedules of the vehicles. This in other word improves the level of service provided. Again effective information management leads to higher profits through better fleet management. This also helps in providing timely information to customers or passengers. Advance vehicle arrival time allows travelers to make better travel scheduling and planning.
3. **Safety and Security** – Quick location of vehicle allows faster security response both for travelers and driver. Also better information helps in quick response to accidents, weather, road condition and other vehicle related problems.

#### VIII. CONCLUSION

Automatic Vehicle Location (AVL) is an advanced method used to track and monitor any remote vehicle equipped with a software unit that receives and transfers signals through GPS satellite. The results presented in this paper contain execution of Startup routine, Logs of Tracking Server and Pointing out current location of vehicle. For vehicle tracking in real time, in-vehicle unit and a tracking server is used. If the distance between vehicle and tracking server is less than RFID can be

used. For more distance, GSM/GPRS modem on GSM network by using SMS or using direct TCP/IP connection with tracking server through GPRS is used. For this, tracking server also has GSM/GPRS modem that receives vehicle location information via GSM network and stores this information in database. This information is available to authorized users of the system via website over the internet. Therefore AVL can be used for both the small scale as well as large scale based projects and this technology is always proved to be beneficial for the society.

#### REFERENCES

- [1] G. T. French (1996) Understanding the GPS. 1st Edition. Bethesda, GeoResearch Inc.
- [2] J.B. TSUI (2000) Fundamentals of Global Positioning System Receivers. 1st Edition. John Willey & Sons Inc. GPS Images.
- [3] R. Parsad, M. Ruggieri (2005) Applied Satellite Navigation Using GPS, GALILEO, and Augmentation Systems. London, ARTECH HOUSE.
- [4] R. Steel et al (2001) GSM, cdmaOne and 3G Systems. Chichester, John Willey & Sons Inc.
- [5] T. Halonen et al (2003) GSM, GPRS and EDGE Performance. 2nd Edition. Chichester, John Willey & Sons Ltd.
- [6] GPRS (General Packet Radio Service), HSCSD & EDGE. <http://www.mobile-phones-uk.org.uk/gprs.html>.
- [7] Telit Wireless Solutions (2008) GM862-GPS Modem. Microchip (2007) PIC18FXX8 Datasheet.
- [8] Transportation District's Automatic Vehicle Location System [online:] <http://www.itsdocs.fhwa.dot.gov/research.html>.
- [9] Vehicle Tracking Systems Overview [Online:] <http://www.roseindia.net/technology/gps/automatic-vehicle-location.shtml>.
- [10] Elit Wireless Solutions (2007) GM862-GPS Hardware user guide. 1vv0300728 Rev. 8 - 20/09/07 World Academy of Science Engineering and Technology 61 2010 99.
- [11] RFID-<http://www.rfid-handbook.de/rfid/>