

SOLAR TRACKING UNIT

Generally, solar panels are stationary and do not follow the movement of the sun. Here is a solar tracker system that tracks the sun's movement across the sky and tries to maintain the solar panel perpendicular to the sun's rays, ensuring that the maximum amount of sunlight is incident on the panel throughout the day. The solar tracker starts following the sun right from dawn, throughout the day till evening, and starts all over again from the dawn next day.

Fig. 1 shows the circuit of the solar tracking system. The solar tracker comprises comparator IC LM339, H-bridge motor driver IC L293D (IC2) and a few discrete components. Light-dependent resistors LDR1 through LDR4 are used as sensors to detect the panel's position relative to the sun. These provide the signal to motor driver IC2 to move the solar panel in the sun's direction. LDR1 and LDR2 are fixed at the edges of the solar panel along the X axis, and connected to comparators A1 and A2, respectively. Presets VR1 and VR2 are set to get low comparator output at pins 2 and 1 of comparators A1 and A2, respectively, so as to stop motor M1 when the sun's rays are perpendicular to the solar panel.

When LDR2 receives more light than LDR1, it offers lower resistance than LDR1, providing a high input to comparators A1 and A2 at pins 4 and 7, respectively. As a result, output pin 1 of comparator A2 goes high to rotate motor M1 in one direction (say, anti-clockwise) and turn the solar panel.

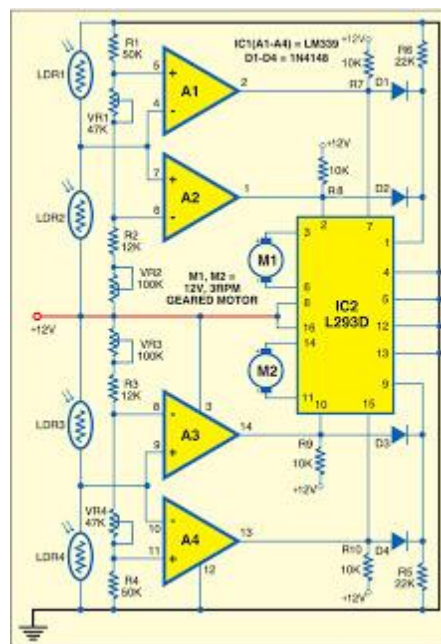



When LDR1 receives more light than LDR2, it offers lower resistance than LDR2, giving a low input to comparators A1 and A2 at pins 4 and 7, respectively. As the voltage at pin 5 of comparator A1 is now higher than the voltage at its pin 4, its output pin 2 goes high. As a result, motor M1 rotates in the opposite direction (say, clock-wise) and the solar panel turns.

Source: <http://electronics hobbycorner.blogspot.in/2013/04/solar-tracking-unit.html>