

Transmission Planning – a Probabilistic Load Flow Perspective

Constantin Barbulescu, Gh. Vuc, Stefan Kilyeni, Dan Jigoria-Oprea, and Oana Pop

Abstract—Perhaps no single issue has been cited as either the root cause and / or the greatest challenge to the restructured power system then the lack of adequate reliable transmission. Probabilistic transmission planning has become increasingly necessary and important in recent years. The transmission planning analysis carried out by the authors, spans a 10-year horizon, taking into consideration a value of 2 % load increase / year at each consumer. Taking into consideration this increased load, a probabilistic power flow was carried out, all the system components being regarded from probabilistic point of view. Several contingencies have been generated, for assessing the security of the power system. The results have been analyzed and several important conclusions were pointed. The objective is to achieve a network that works without limit violations for all (or most of) scenario realizations. The case study is represented by the IEEE 14 buses test power system.

Keywords—Contingency, load, operating state, probabilistic power flow, transmission planning.

I. INTRODUCTION

THE fundamental objective of transmission planning is to develop the system as economically as possible and maintain an acceptable reliability level. The deterministic N-1 planning criterion for transmission systems has been used across the power industry for many years and will continue to be a benchmark criterion. But, it has two main weaknesses. First, the consequences of single-component failure events are analyzed, but their probabilities of occurrence are usually ignored. Second, multiple component failures are excluded from consideration. Also, it is difficult to deal with all the uncertainty factors using deterministic methods, including uncertainties in load forecast and the location of future generation [1].

The probabilistic method is not intended to replace the deterministic criterion but adds one more dimension to enhance the transmission planning process.

Manuscript received April 27, 2008.

C. Barbulescu, is with “Politehnica” University of Timisoara, RO-300223 Romania (phone: +40-256-403430; fax: +40-256-403416; e-mail: constantin.barbulescu@et.upt.ro).

Gh. Vuc, is with “Politehnica” University of Timisoara, RO-300223 Romania (phone: +40-256-403410; fax: +40-256-403416; e-mail: gheorghe.vuc@et.upt.ro).

St. Kilyeni, is with “Politehnica” University of Timisoara, RO-300223 Romania (phone: +40-256-403416; fax: +40-256-403416; e-mail: stefan.kilyeni@et.upt.ro).

D. Jigoria-Oprea, is with “Politehnica” University of Timisoara, RO-300223 Romania (phone: +40-256-403430; fax: +40-256-403416; e-mail: dan.jigoria@et.upt.ro).

O. Pop, is with “Politehnica” University of Timisoara, RO-300223 Romania (phone: +40-256-403430; fax: +40-256-403416; e-mail: oana.pop@et.upt.ro).

II. PROBABILISTIC PLANNING VS. DETERMINISTIC PLANNING

The deterministic N-1 criterion is based on the worst case study. The worst case may be missed. For example, the system peak load is generally used as one of the worst conditions. However, some serious system problems may not necessarily happen at the peak load. Also, even if a system withstands the worst case, the system is still exposed to risk under less than worst case conditions. It is worthy to identify the risk level associated with the N-1 criterion. This is one of tasks in probabilistic transmission planning.

Most major outages are usually associated with multiple component failures or cascading events. These severe outages suggest that the single-contingency criterion may not be sufficient to preserve a reasonable level of system reliability. However, on the other hand, it is almost impossible for any utility to justify the N-2 or N-3 principle in transmission planning. One alternative is to bring risk management into planning practice and keep system risk within an acceptable level.

A complete system planning process includes societal, environmental, technical and economical assessments with probabilistic reliability evaluation as a part of the whole assessment process. Fig. 1 gives the conceptual example in which seven candidate planning alternatives are assumed at the beginning. Two of them are immediately excluded based on environmental, societal or political considerations. The deterministic technical criteria including the N-1 principle are applied to the remaining five alternatives. Two more alternatives are eliminated from the candidate list due to their inability to meet the deterministic contingency criterion. Then probabilistic reliability evaluation and economic analysis are performed to select the best scenario. Both N-1 principle and reliability criteria have been satisfied [1].

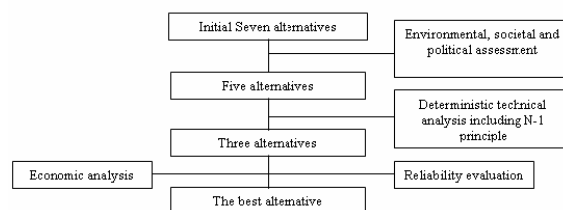

Fig. 1 System planning process

III. DESCRIPTION OF THE TEST POWER SYSTEM USED

To present the appliance of the proposed method we are using IEEE 14 bus test power system (Fig. 2). It contains 14 buses: 9 buses at 115 kV and 5 buses at 230 kV. Regarding the configuration of the test power system analyzed, there is a distribution as follows: 5 P-U buses, 11 P-Q buses and 21 branches. The system contains one single area.

IV. METHODOLOGY OF THE PROBABILISTIC POWER FLOW STUDY

In the current paper the work is based on a software instrument designed for transmission congestion management. It was developed within the Electrical Power Engineering Department from "Politehnica" University of Timisoara, Romania. Based on this instrument the power system is analyzed using a new approach named probabilistic power flow, part of the stochastic analysis.

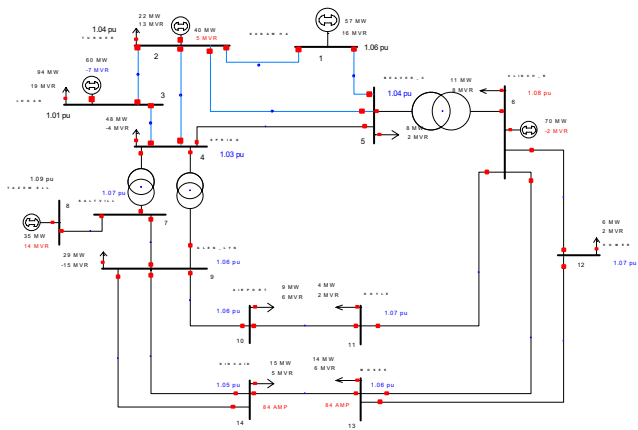

Fig. 2 IEEE 14 bus test power system configuration scheme

Now, the authors are making another step. They are trying to use the developed instrument for transmission planning too, approaching to the probabilistic transmission planning.

In the following we are presenting the sources of uncertainty within the electric power industry.

a) Generation availability. In this case the uncertainties are caused by unplanned outages, equipment failures, protective relaying, economic factors including fuel prices and market prices, reserve availability, reactive power requirements, climatic variables such as precipitation and hydro-power availability, environmental regulations including emissions restrictions.

It is foreseen that new generating capacity will be from non-traditional sources including renewable sources such as wind and photovoltaic, fuel cells, and gas micro turbines. These sources will connect and disconnect from the network with greater randomness than traditionally scheduled, utility-controlled generation sources. Information regarding performance details and device models, particularly dynamic models, are lacking.

b) Transmission capacity. For this network element the uncertainties are caused by line ratings, weather-related factors including ambient temperature, wind and ice storms, geophysical events including lightning and earthquakes, geomagnetic storms, unplanned outages and equipment failures, trans-regional power exchanges.

c) Load uncertainties caused by weather-related factors including temperature and precipitation, economic factors including economic growth, new types of electronically-controlled loads, variations in load power factors.

d) Distribution system. In this case the sources of uncertainties are represented by equipment failures, unplanned outages, economic factors including distribution classes, load shedding policies, weather related factors such as ambient temperature.

In our instrument we are modelling all the three sources of

uncertainties (the generating units, the transmission network and the loads). The entire power system is regarded from a probabilistic point of view. For this new scenario we were developing a code that allows us to generate a power flow for a specific power system.

In the following we are treating the three sources of uncertainties presented in a power system.

In case of the generating units, starting from a random binary array we are imposing which generating units are connected and which are disconnected. In this manner we are simulating generating units contingencies. Maximum three disconnected generating units are accepted. For the connected generating units the active generated power is determined, based on the minimum and maximum limit of the deterministic active generated power. Also, for these generators the AGC status has to be conserved.

The transmission network practically has only two states. It can or can not transmit the power. In our approach we are starting from a random binary array, representing the branches which are connected and disconnected. Maximum three disconnected branches are allowed.

In case of the probabilistic consumer we are starting from the deterministic consumed power for each P-Q bus. Using these values and a random numbers generator we are determining the probabilistic consumed powers for each P-Q bus.

At this point, all the uncertainties sources within a real power system are modelled. The principles stated above, are repeated for a certain number of times. This number of times is called samples. In our previous work [4], the authors established an optimal number of 1000 samples. According to this assumption we are generating a number of 1000 samples. For each sample we are generating (using Matlab software) a script file. In the following this script file is loaded in Powerworld software, in this case Powerworld being operated in script mode. This auxiliary script file (that is to be loaded in Powerworld) contains all the necessary data for generating the two types of contingencies mentioned above and for effectuating an optimal power flow according to the new operating conditions. For each branch we are expecting to obtain different Gauss type distribution curves, most of them very close to a normal distribution, based on the apparent power flows from all those 1000 samples generated for the respective branch. Using Statistica software, applying different tests (Shapiro-Wilk and Kolmogorov-Smirnov), we are validating the curves previously obtained.

V. PROBLEM FORMULATION

For actual restructured power markets the locational marginal pricing appears as the best method to deal with the mixture of engineering and financial problems of optimal dispatch and open access to transmission network. This is done by solving an optimal problem, with marginal prices as part of solution.

The objective function for such a problem is defined [5] as

$$OF = \sum_{i \in n \setminus SB} C_{Gi}(P_{Gi}) + \sum_{i \in n \setminus SB} C_{Ci}(P_{Ci}) + C_{SB}(P_{SB}) + \sum_{i,j \in n} PT \cdot (S_{ij} - S_{ij}^{\max}) \quad (1)$$

where, $C_{Gi}(P_{Gi})$ is the generation hourly cost for bus i , $C_{Ci}(P_{Ci})$ is the cost of reducing electric power demand for bus i , $C_{SB}(P_{SB})$

is the generation cost for slack bus, and $PT(S_{ij} - S_{ij}^{\max})$ is the penalty cost of exceeding the MVA maxim limit of a branch.

The constraints for active and reactive power are:

$$\sum_{i \in n \setminus NE} P_{Gi} + P_{NE} = \sum_{i \in n \setminus NE} P_{Ci} + \Delta P_{\Sigma} \quad (1a)$$

$$P_{Gi}^{\min} \leq P_{Gi} \leq P_{Gi}^{\max}; \quad i \in n \quad (1b)$$

$$Q_{Gi}^{\min} \leq Q_{Gi} \leq Q_{Gi}^{\max}; \quad i \in n \quad (1c)$$

$$P_{Ci}^{\min} \leq P_{Ci} \leq P_{Ci}^{\max}; \quad i \in n \quad (1d)$$

$$Q_{Ci}^{\min} \leq Q_{Ci} \leq Q_{Ci}^{\max}; \quad i \in n \quad (1e)$$

$$U_i^{\min} \leq U_i \leq U_i^{\max}; \quad i \in n \quad (1f)$$

$$P_{Gi} - P_{Ci} = \sum_{i \in n} U_i \cdot Y_{ij} \cdot U_j \cdot \cos(\delta_i - \delta_j - \psi_{ij}); \quad i \in n \quad (1g)$$

$$Q_{Gi} - Q_{Ci} = \sum_{i \in n} U_i \cdot Y_{ij} \cdot U_j \cdot \sin(\delta_i - \delta_j - \psi_{ij}); \quad i \in n \quad (1h)$$

$$P_{lij} < P_{lij}^{\max};$$

$$P_{lij} = U_i^2 \cdot Y_{lij} \cdot \cos \psi_{Lij} - U_i \cdot Y_{lij} \cdot U_j \cdot \cos(\delta_i - \delta_j - \psi_{Lij}) \quad (1i)$$

$$t_l^{\min} \leq t_l \leq t_l^{\max} \quad (1j)$$

and when the load P_{Ci} is considered as probabilistic value the problem become a probabilistic load flow problem more complex and more difficult to solve. A natural and realistic probabilistic distribution for power demand is normal distribution $N(\mu, \sigma)$ which we used in our simulation.

In our work we considered the Monte Carlo simulation and an interface to Powerworld software to solve each deterministic case corresponding to Monte Carlo set of demand values.

VI. NUMERICAL SIMULATIONS

In the following we are presenting the histograms associated with the probabilistic apparent power flow on the system branches. The number of histograms corresponds to the number of system branches, but one single histogram contains information from all the 1000 samples generated by Monte Carlo simulation.

On the histograms, the first mark corresponds to the apparent power flow deterministic value. And the second mark corresponds to the maximum transfer allowable limit on the analyzed branch.

In Fig. 3 it is presented the probabilistic apparent power flow on branch 1-5. Maximum transfer allowable limit on branch 1-5 (230 kV electrical overhead line) for apparent power is 150 MVA. Analyzing the histogram in correspondence with the frequency table (Table I), it can be observed that the probabilistic values are concentrated around its limit (having a high frequency class).

The first zone of the histogram corresponds to the contingencies generated when the analyzed branch is disconnected. There are a number of 96 cases for the entire analyze.

TABLE I
FREQUENCY CLASS TABLE FOR 1-5 BRANCH

Probabilistic values	Count	Cumulative	Percent
-100.00 < x ≤ 0.00	96	96	9.61924
0.00 < x ≤ 100.000	51	147	5.11022
100.00 < x ≤ 200.00	847	994	84.86974
200.00 < x ≤ 300.00	3	997	0.30060
300.00 < x ≤ 400.00	0	997	0.00000
400.00 < x ≤ 500.00	1	998	0.10020

The deterministic value for the apparent power flow on the analyzed branch is 37 MVA. But, the probabilistic power flow values in this zone are characterized by a very low frequency class (51 appearance times).

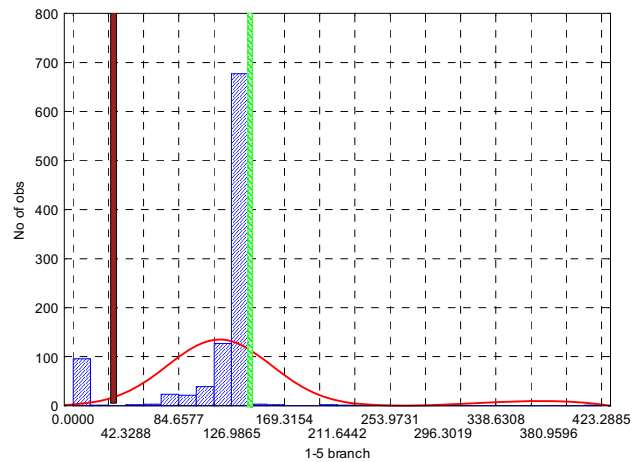

Fig. 3 Apparent power flow on branch 1-5

Starting from the values presented on the histogram, we could identify the following regimes with contingencies, for the zone between the deterministic value and the maximum limit:

- congestion on branch 1-2 (100.1 %). The scenario for this regime: branches 5-6 and 6-13 and the generating unit from P-U bus number 3 are disconnected;
- congestion (190 %) on branch 7-9 and branch 13-14 is loaded at its limit, in the following scenario: branches 6-11 and 5-6 and the generating unit from P-U bus 6 are disconnected.

The last zone of the histogram contains probabilistic values greater than the maximum transfer allowable limit on branch 1-5 for the apparent power flow. From the table frequency class we are focusing on values between 150 and 200 MVA, respectively greater than 200 MVA. Analyzing these cases the following conclusions were pointed out:

- it can not be established a valid operating regime when branches 6-12 and 12-13 are disconnected and the generating unit from P-U bus 2 is disconnected;
- branch 1-2 is loaded at limit, when branches 2-5 and 4-7 and the generating unit from P-U bus 2 are disconnected;
- branches 1-2 and 7-9 are loaded at limit when branches 4-7 and 1-5 and the generating unit from P-U bus 6 are disconnected;
- branch 4-7 is loaded at limit and branch 5-6 is congested (168 %) when branches 7-9 and 4-9 and the generating unit from P-U bus 6 are disconnected;

- branch 3-4 is congested (168 %) when branches 2-3 and 6-11 and the generating unit from P-U bus 2 are disconnected.

Analyzing the frequency class table, it can be seen that these cases are characterized by a reduced frequency. But the regimes could affect in an important manner the power system security. Congestion situations were identified starting from the histogram. These congestions can not be easily identified using deterministic power flow.

In Fig. 4 it is presented the probabilistic apparent power flow on branch 1-2 (230 kV electrical overhead line). The maximum transfer allowable limit is 135 MVA and the deterministic apparent power flow is 39 MVA.

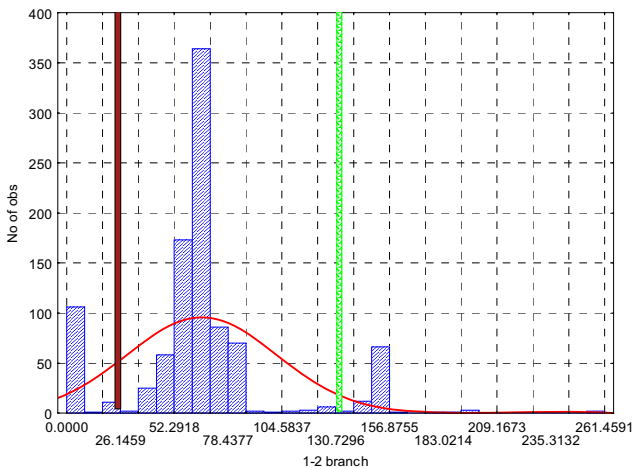

Fig. 4 Apparent power flow on branch 1-2

TABLE II
FREQUENCY CLASS TABLE FOR 1-2 BRANCH

Probabilistic values	Count	Cumulative	Percent
$-50.00 < x \leq 0.00$	106	106	10.62124
$0.00 < x \leq 50.00$	84	190	8.41683
$50.00 < x \leq 100.00$	709	899	71.04208
$100.00 < x \leq 150.00$	66	965	6.61323
$150.00 < x \leq 200.00$	31	996	3.10621
$200.00 < x \leq 250.00$	0	996	0.00000
$250.00 < x \leq 300.00$	2	998	0.20040

During the contingencies probabilistic generated, this branch was disconnected for 106 times. The first peak from the histogram and the frequency table reveal this fact.

The second zone of the histogram contains the probabilistic values characterized by an expected behaviour. Analyzing the histogram, in correspondence to the frequency table, it can be seen that the probabilistic values are concentrated between the power flow deterministic value and the limit of the branch.

The third zone of the histogram contains probabilistic apparent power flows that have greater value than the limit of the branch.

- the following branches are congested: 1-5 (108 %), 3-4 (157 %) and 4-5 (126 %). This regime is possible when branches 7-8, 1-2 and the generating unit from P-U bus 3, are disconnected;
- when branches 12-13, 6-12 and the generating unit from P-U bus 2, are disconnected, a valid operating regime can not be established;

- branch 1-5 is loaded at limit when branches 7-9, 1-2 and the generating unit from P-U bus 2 are disconnected. When branches 6-13, 1-2 and the generating unit from P-U bus 2 are disconnected, the same results are obtained. Another scenario that leads us to the same problem is represented by branches 4-7, 1-2 and P-U bus 2, which are disconnected;
- branches 1-5 and 4-5 are loaded at limit and branch 3-4 is congested (167 %), when branches 12-13, 1-2 and the generating unit from P-U bus 3 are disconnected;
- branch 1-5 is loaded at limit and branch 3-4 is congested (156 %). The contingencies involved are: branches 10-11, 1-2 and the generating unit from P-U bus 3 are disconnected;
- branch 1-2 is loaded at limit when branches 10-11, 9-14 and P-U bus 2 are disconnected. Disconnecting the branches 2-5, 4-7 and the same generating unit we obtain the same results. Also when branches 4-5, 1-5 and P-U bus 3 are disconnected;
- branches 1-5 and 4-5 are loaded at limit and branch 3-4 is congested (190 %) within the following scenario: branches 7-9, 1-2 and P-U bus 3 are disconnected;
- when branches 13-14, 4-9 and P-U bus 3 are disconnected, branch 3-4 is congested (112 %);
- branch 2-4 is loaded at limit when branches 2-5, 9-10 and P-U bus 8 are disconnected;
- branch 7-9 is congested (144 %) when branches 6-12, 5-6 and P-U bus 6 are disconnected;
- branch 3-4 is congested (140 %) when branches 6-12, 1-2 and P-U bus 3 are disconnected;
- branch 5-6 is congested (170 %) when branches 7-9, 4-9 and P-U bus 6 are disconnected.

In Fig. 5 it is presented the probabilistic apparent power flow on branch 4-9 (230 / 115 kV electrical transformer). The maximum transfer allowable limit is 75 MVA and the deterministic apparent power flow is 20 MVA.

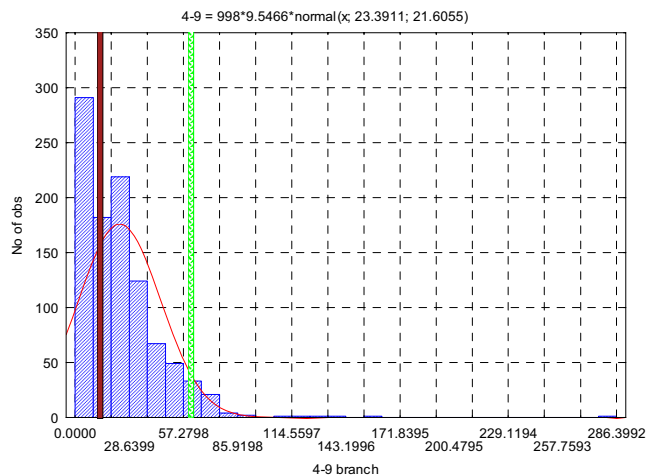

Fig. 5 Apparent power flow on branch 4-9

TABLE III
 FREQUENCY CLASS TABLE FOR 4-9 BRANCH

Probabilistic values	Count	Cumulative	Percent
$-50.00 < x \leq 0.00$	109	109	10.92184
$0.00 < x \leq 50.00$	782	891	78.35671
$50.00 < x \leq 100.00$	101	992	10.12024
$100.00 < x \leq 150.00$	4	996	0.40080
$150.00 < x \leq 200.00$	1	997	0.10020
$200.00 < x \leq 250.00$	0	997	0.00000
$250.00 < x \leq 300.00$	1	998	0.10020

In case of the histogram presented, the probabilistic values are concentrated around the deterministic value of the apparent power flow. Outside the maximum transfer allowable limit there are only a few probabilistic values, characterized by a reduced frequency.

The following interesting conclusions can be obtained from the histogram and the frequency table:

- branch 1-2 is loaded at limit, when branches 7-9 and 4-9 are disconnected. The same result is obtained when branches 3-4, 9-10 and P-U bus 6 are disconnected. Also when branches 6-12, 4-7 are disconnected;
- branch 3-4 is congested, when branches 2-3, 6-11 and P-U bus 6 are disconnected. The same result is obtained when branches 7-9, 2-3 and P-U bus 3 are disconnected.

Starting from the branch 4-9 analysis we had identified one single congestion situation.

In Fig. 6 it is presented the probabilistic apparent power flow on branch 5-6 (230 / 115 kV electrical transformer). The maximum transfer allowable limit is 75 MVA and the deterministic apparent power flow is 13 MVA.

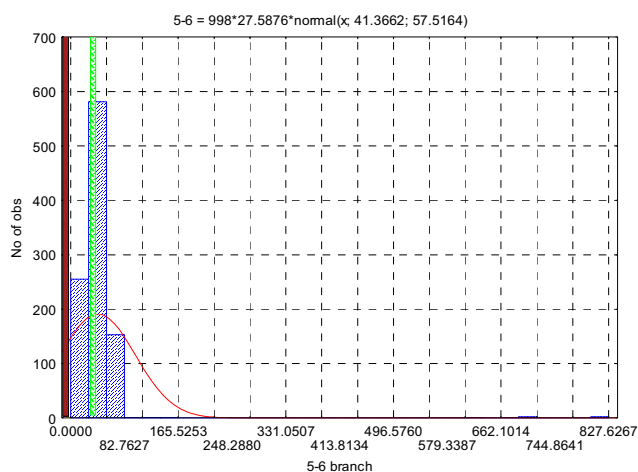

Fig. 6 Apparent power flow on branch 5-6

 TABLE IV
 FREQUENCY CLASS TABLE FOR 5-6 BRANCH

Probabilistic values	Count	Cumulative	Percent
$-100.00 < x \leq 0.00$	103	103	10.32064
$0.00 < x \leq 100.00$	887	990	88.87776
$100.00 < x \leq 200.00$	2	992	0.20040
$200.00 < x \leq 300.00$	0	992	0.00000
$300.00 < x \leq 400.00$	0	992	0.00000
$400.00 < x \leq 500.00$	0	992	0.00000
$500.00 < x \leq 600.00$	0	992	0.00000

$600.00 < x \leq 700.00$	2	994	0.20040
$700.00 < x \leq 800.00$	2	996	0.20040
$800.00 < x \leq 900.00$	2	998	0.20040

Analyzing the histogram in correspondence with Table IV, the probabilistic apparent power flow values are concentrated around the limit of the branch. This fact denotes that there are congested branches in the power system, which can be investigated based on the histogram of this branch. Starting from the histogram, in correspondence with Table IV, the following interesting situations can be identified:

- if branches 6-12, 12-13 and the generating unit from P-U bus 2 are disconnected, then a valid operating regime cannot be established;
- branch 5-6 is congested (104 %), when branches 7-8, 4-7 and the generating unit from P-U bus 6 are disconnected;
- branch 2-4 is congested (114 %), when branches 1-5, 2-5 and the generating unit from P-U bus 8 are disconnected;
- branch 2-3 is congested (113 %), when branches 3-4, 1-2 and the generating unit from P-U bus 3 are disconnected;
- if branches 7-8, 13-14 and the generating unit from P-U bus 2 are disconnected, then branch 1-2 is loaded at limit and branch 3-4 is congested (109 %);
- branch 1-5 is loaded at limit when branches 7-9, 1-2 and the generating unit from P-U bus 6 are disconnected ;
- if branches 7-9, 4-9 and the generating unit from P-U bus 6 are disconnected, then branch 4-7 is loaded at limit and branch 5-6 is congested (168 %);
- branch 1-2 is loaded at limit when branches 3-4, 1-5 and the generating unit from P-U bus 8 are disconnected. The same result is obtained when branches 3-4, 9-10 and the same generating unit are disconnected.

Analyzing this branch several congestion situations are identified, that could appear in the IEEE 14 buses test power system.

VII. TRANSMISSION PLANNING ANALYSIS

In the current paper, the authors proposed an individual increase of 2 %, for a period of 10 years, for each P-Q bus. The new increased consumption (active and reactive powers) was introduced in Matlab and probabilistic power flow followed in Powerworld software. This increase of 2 % leads to a global increase of 20 %, for the horizon of time taken into consideration.

For the case of reactive power flow average probabilistic values have been calculated (Table V). The deterministic reactive power values for each P-Q bus are also presented in this table. In the last row of table we had calculated the rapport between average value of reactive probabilistic powers and the reactive power deterministic value for each P-Q bus.

Analyzing the previous table, from the last row it can be observed that an individual increase of 2 % leads to a 20 % increase for almost every consumer. This corresponds to the global increase within the whole horizon of time.

In Table VI it is presented an example of the probabilistic reactive power consumed in each P-Q bus, from the sample number 1000. In the following, it has been calculated the rapport between these values and the deterministic reactive power consumed.

TABLE V
LOAD INCREASE ANALYSIS

P-Q bus number	2	3	4	5	6	9	10	11	12	13	14
Average	15.25	22.82	-4.672	1.92	8.99	-17.59	6.96	2.16	1.91	6.93	5.98
Deterministic	12.7	19	-3.9	1.6	7.5	-14.6	5.8	1.8	1.6	5.8	5
Average value/ Deterministic	1.20077	1.201285	1.197967	1.195544	1.199904	1.204554	1.200576	1.2008	1.196206	1.195209	1.196064

TABLE VI
LOAD INCREASE ANALYSIS – EXAMPLE

P-Q bus number	2	3	4	5	6	9	10	11	12	13	14
Sample 1000	16.31	22.08	-5.2	1.91	9.75	-19.15	6.76	1.96	2.08	8.05	5.48
Sample1000 / Deterministic value	1.284252	1.162105	1.333333	1.19375	1.3	1.311644	1.165517	1.088889	1.3	1.387931	1.096

Analyzing the table, it can be observed that an individual increase of 2 % / year / consumer, within a time horizon of 10 years, can lead to an individual increase greater than 20 % / consumer (30 %, 33 %, 38 %).

VIII. CONCLUSION

The weakness of deterministic transmission planning criteria is their inability to capture probabilistic characteristics in power systems including uncertainties in load forecast, generating units and random failure of system equipment etc. This may lead to either overinvestment or insufficient reliability in a planning project.

Using the instrument developed, several congestion situations unrevealed by deterministic analysis have been identified. These situations are very difficult to be pointed out using classical deterministic power flow. Our instrument is using a new approach named probabilistic power flow, where all the components of the power system are regarded from probabilistic point of view.

An individual load increase, at each consumer, leads us to a total increase equal with the global increase within the entire horizon of time. This fact was also pointed out by probabilistic power flow; it leads to under sizing if it is not known by the power system planner.

By transmission planning based on probabilistic power flow, it was shown that an individual load increase, leads to an individual load increase greater than the initial one, for some operating states.

REFERENCES

- [1] IEEE Power & Energy Magazine for Electric Power Professionals, Vol. 5, Number 5, September / October 2007.
- [2] C. Barbulescu, Gh. Vuc, St. Kilyeni, "Probabilistic Load Modelling Influences on the Load Flow. Case Study TEST25 Test Power System", in Proceedings of the International Youth Conference on Energetics 2007 (IYCE 2007), Budapest, Hungary, 2007, pp.175.
- [3] Gh. Vuc, C. Barbulescu, St. Kilyeni, "Transmission Network's Congestion with Probabilistic Load Model", in Proceedings of the International Youth Conference on Energetics 2007 (IYCE), Budapest, Hungary, 2007, pp.73.
- [4] C. Barbulescu, I. Ardelean, St. Kilyeni, Gh. Vuc. "Probabilistic power flow. Establishment of the optimal sample set for Monte Carlo simulations for Test50 bus test power system", in Proceedings of the National Conference and Power Engineering Exhibition CNEE 2007, Sinaia, 7-8 November 2007, pp. 1040-1047.
- [5] M. Nemes, D. Paunescu, G. Vuc, "Analyzing the Impact of Probabilistic Load On Systems Hourly Cost", in Proceedings of the 1st International Conference on Modern Power Systems (MPS), Cluj-Napoca, Romania, 2006.
- [6] A.M. Leite Da Silva, J.G. De Carvalho Costa, C. Monteiro Mattar, "A Probabilistic Approach for Determining the Optimal Amount of Transmission System Usage", in IEEE Transactions on Power Systems, Vol. 21, Issue 4, Pp.1557-1564, 2007.
- [7] Georgia Institute of Technology: Comprehensive Power System Reliability Assessment, Final Project Report, Power Systems Engineering Research Center, April 2006.
- [8] A.B. Rodrigues, M.G. Da Silva, Probabilistic Assessment of Available Transfer Capability Based on Monte Carlo Method With Sequential Simulation, in IEEE Transactions on Power Systems, Volume 22, Issue 1, Pp: 484 – 492, 2007.