

REACTIVE POWER CONTROL AND TRANSMISSION LOSS REDUCTION WITH REALIZATION OF SVC AND TCSC

J. V. Parate

Electrical Department,
Govt. College of Engineering, Amravati (MS), India
Jaiwant.parate@gmail.com

Associate Prof. A. S. Sindekar

Electrical Department,
Govt. College of Engineering, Amravati (MS), India
assindekar@rediffmail.com

Abstract :

In general the problem of reactive power control is viewed from two aspects: load compensation and voltage support. This is utilized to reduce the total system real power loss or voltage deviation as an objective to compute optimal settings of reactive power output or terminal voltages of generating plants, transformer tap settings and output of other compensating devices such as capacitor banks and synchronous condensers. This paper has considered the setting of flexible AC transmission system (FACTS) devices as additional control parameters for transmission loss reduction in power system and the impact on system loss reduction in power system. Static models of two FACTS devices consisting of static var compensator (SVC), thyristor controlled series compensator (TCSC) have been included in the problem formulation. The proposed algorithm has been applied to 9-bus test system and IEEE 14-bus system.

Keyword: Reactive power, Newton- Raphson technique, SVC, TCSC

I. INTRODUCTION

Almost all bulk electric power is generated, transmitted and consumed in an alternating current (AC) network. Elements of AC systems produce and consume two kinds of power: real power (measured in watts) and reactive power (measured in volt-amperes reactive, or var). Real power accomplishes useful work (e.g., running motors and lighting lamps). Reactive power supports the voltages that must be controlled for system reliability.

It is expected that the secure, efficient and economical operation of power system will become more difficult because of more complex power flow in the future. As a result, the cost reduction and efficiency improvement are needed not only for the power plant operation but also for the power system operation.

Voltage profile is improved by controlling the production, absorption and flow of reactive power throughout the network. Reactive power flows are minimized so as to reduce system losses.

Transmission losses can be calculated based on the natural properties of components in the power system: resistance, reactance, capacitance, voltage, current, and power, which are routinely calculated by utility companies as a way to specify what components will be added to the systems, in order to reduce losses and improve the voltage levels. The centralized voltage reactive control is one such control which can help not only to keep the system voltages within specified limits but also to preserve the reactive power balances for enhanced security and to decrease the transmission losses for the efficient system operation.

Power flow solution is a solution of the network under steady state conditions subjected to certain constraints under which the system operates. The power flow solution gives the nodal voltages and phase angle given a set of power injections at all buses and specified voltages. Voltage regulation is achieved by controlling the production, absorption and flow of reactive power throughout the network. Reactive power flows are minimized so as to reduce system losses. Sources and sinks of reactive power, such as shunt capacitors, shunt reactors, rotating synchronous condensers and SVC's are used for this purpose. Thyristor Controlled series

Compensators are versatile devices that controls the reactive power injection at a bus using power electronic switching components. The reactive source is usually a combination of reactors and capacitors.

The proposed power flow algorithm for reduction of transmission loss incorporating TCSC and SVC devices is independent of the system size. The algorithm uses Newton-Raphson technique.

II. POWER FLOW CONTROL

The power transmission line can be represented in power system from bus “p” to “q”. The active power transmitted between bus p and q is given by:

$$P = \frac{V_p V_q}{X} \sin(\delta_p - \delta_q) \tag{1}$$

Where V_p and V_q are the voltages at the buses, ($\delta_p - \delta_q$) is the angle between the voltages and X is the line impedance.

The power flow can be controlled by altering the voltages at a node, the impedance between the buses and the angle between the end voltages. The reactive power transmitted between bus p and q is given by:

$$Q = \frac{V_p^2}{X} - \frac{V_p V_q}{X} \cos(\delta_p - \delta_q) \tag{2}$$

NEWTON-RAPHSON Technique

The Newton- Raphson technique has proved most successful owing to its strong convergence characteristics. The power flow Newton-Raphson algorithm is expressed by using Jacobian matrix.

$$\begin{bmatrix} \Delta P \\ \Delta Q \end{bmatrix} = \begin{bmatrix} J1 & J2 \\ J3 & J4 \end{bmatrix} * \begin{bmatrix} \Delta \delta \\ \Delta V \end{bmatrix} \tag{3}$$

Where ΔP and ΔQ are bus active and reactive power mismatches, while δ and V are bus magnitude and angle, respectively.

Jacobian is the matrix of partial derivatives of real and reactive power with respect to the voltage magnitude and angles.

III. MODELING OF STATIC VAR COMPENSATOR

The Static VAR Compensator (SVC) is the shunt connected FACTS controller whose main function is to regulate the voltage at a given bus by controlling its continuous variable susceptance, which is adjusted in order to achieve a specified voltage magnitude while satisfying constraint conditions. SVC total susceptance model shown in Fig.1. A changing susceptance B_{svc} represents the fundamental frequency equivalent susceptance of all shunt modules making up the SVC. This model is an improved version of SVC models.

Representation of SVC Susceptance Model

In power system, the SVC can be an adjustable reactance with reactance limit. The equivalent circuit shown in figure is used to derive SVC nonlinear power equation and the linearised equation required by Newton’s method.

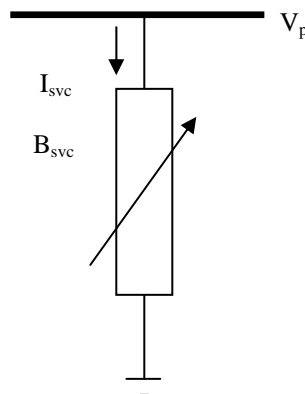

Fig 1. Variable shunt susceptance

Current drawn by the SVC is

$$I_{svc} = jB_{svc} V_p \quad (4)$$

and the reactive power drawn by the SVC, which is injected reactive power at bus p

$$Q_{svc} = Q_p = -V^2 B_{svc} \quad (5)$$

The equivalent susceptance B_{svc} is taken to be

$$\begin{bmatrix} \Delta P_p \\ \Delta Q_p \end{bmatrix} = \begin{bmatrix} 0 & 0 \\ 0 & Q_p \end{bmatrix} \times \begin{bmatrix} \Delta \delta_p \\ \Delta B_{svc}/B_{svc} \end{bmatrix} \quad (6)$$

The variable susceptance B_{svc} is updated according to

$$B_{svc}^{(i)} = B_{svc}^{(i-1)} + (\Delta B_{svc}/B_{svc})^{(i)} \times B_{svc}^{(i-1)} \quad (7)$$

The changing susceptance represents the total SVC susceptance necessary to maintain the nodal voltage magnitude .

IV. MODELING OF THYRISTOR CONTROLLED SERIES COMPENSATOR

The TCSC is based on the concept of a variable series reactance, the value of which is adjusted automatically to constraints the power flow across the branch to specified value. The amount of reactance is determined efficiently using Newton's method. The changing X_{TCSC} is shown in fig 2.

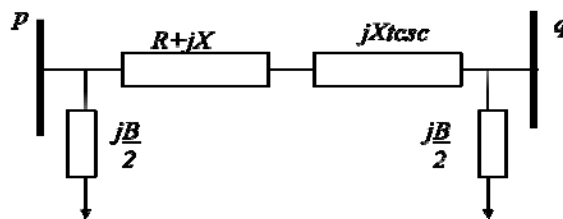

Fig 2. TCSC model with series reactance

The transfer admittance matrix of the variable series compensator is given by

$$\begin{bmatrix} I_p \\ I_q \end{bmatrix} = \begin{bmatrix} jB_{pp} & jB_{pq} \\ jB_{qp} & jB_{qq} \end{bmatrix} \times \begin{bmatrix} V_p \\ V_q \end{bmatrix} \quad (8)$$

For the inductive operation

$$B_{pp} = B_{qq} = -\frac{1}{X_{tcsc}} \quad (9a)$$

$$B_{pq} = B_{qp} = \frac{1}{X_{tcsc}} \quad (9b)$$

The Active and Reactive power equation for bus P are

$$P_p = V_p V_q B_{pq} \sin(\delta_p - \delta_q) \quad (10a)$$

$$Q_p = -V_p^2 B_{pp} - V_p V_q B_{pq} \cos(\delta_p - \delta_q) \quad (10b)$$

The series reactance ΔX_{tcsc} is the incremental change in the reactance.

$$\Delta X_{tcsc} = X_{tcsc}^{(i)} - X_{tcsc}^{(i-1)} \quad (11)$$

Updating the X_{TCSC} of the series reactance is given by

$$X_{tcsc}^{(i)} = X_{tcsc}^{(i-1)} + (\Delta X_{tcsc} / X_{tcsc}^{(i-1)}) X_{tcsc}^{(i-1)} \quad (12)$$

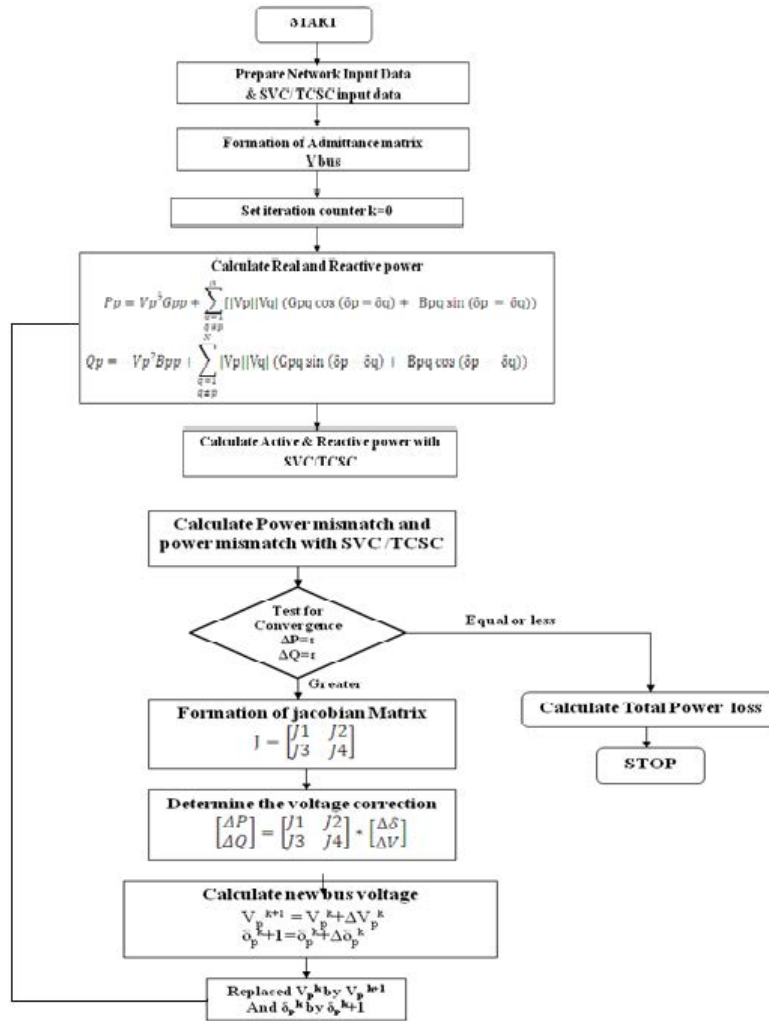

Fig 3. Flow chart

V. SIMULATION AND RESULT

Case-I: 9 Bus Test System

9-bus test system is used to assess the effectiveness of SVC and TCSC models for reduction of transmission loss. The 9 bus test system consists of 3 generator, 9 buses, 9 branches with 230kV and 100MVA base. The system data is taken from [9].

The placement of SVC has been considered at load buses only SVC is connected at bus 5, bus 6 and at bus 8. TCSC connected between line 9-8, 7-8, and between line 4-6.

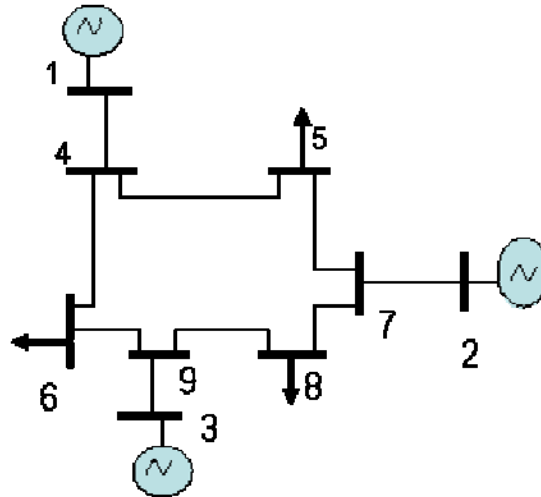

Fig. 4. 9-bus test System.

The SVC is connected to the bus 8, the control aim to keep the voltage at that bus is 1.0 pu. The convergent obtained after 5 iteration. The SVC absorbs 27.4595MVar and Bsvc equal to the -0.2746 pu.

The SVC is connected to the bus 6, The SVC absorbs 15.2861MVar and Bsvc equal to -0.1529 pu.

The SVC is connected to the bus 5, The SVC absorbs -1.4707MVar and Bsvc equal to the 0.0147pu.

Table1

Voltage magnitude and phase angle for 9bus system with and without SVC

Base case			SVC at bus 8		SVC at bus 6		SVC at bus 5	
Ploss5.2996			4.7732		4.6876		4.5858	
Qsvc			27.4595		15.2861		-1.4707	
			B = -0.2746		B = -0.1529		B = 0.0147	
Bus	V (V)	δ Degree	V (V)	δ Degree	V (V)	δ Degree	V (V)	δ Degree
1	1.04	0	1.04	0	1.0400	0	1.0400	0
2	1.025	9.1665	1.025	9.3470	1.0250	9.1612	1.0250	9.1642
3	1.025	4.6373	1.025	4.7307	1.0250	4.6431	1.0250	4.6396
4	1.027	-2.212	1.024	-2.224	1.0220	-2.226	1.0276	-2.2112
5	0.998	-3.982	0.993	-3.994	0.9946	-4.017	1.0000	-3.9825
6	1.014	-3.685	1.0097	-3.695	1.0000	-3.639	1.0145	-3.6816
7	1.0315	3.6373	1.0228	3.7707	1.0299	3.6232	1.0318	3.6367
8	1.020	0.6888	1.0000	0.8129	1.0176	0.6702	1.0202	0.6908
9	1.033	1.9432	1.0270	2.0185	1.0306	1.9406	1.0340	1.9459

Table 2

Comparison of results

	Matlab Programming		Power World Simulator	
	Power loss (MW)	Qsvc MVar	Power loss (MW)	Qsvc MVar
Base case	5.2996	-	5.6	-
SVC at bus 8	4.7732	27.4595	4.9	30.5
SVC at bus 6	4.6876	15.2861	4.7	15.1
SVC at bus 5	4.5858	-1.4707	4.7	-1.5

TCSC is connected between the bus 9 and bus8. The active power loss reduces to the 4.6323MW. The Xtcsc is equal to the -0.04. The active power flow in line 9-8 increased from 24.6MW to 25.5 MW.

TCSC is connected between the bus 7 and bus8. The active power loss reduces to the 4.7775 MW. The Xtcsc is equal to the -0.035. The active power flow in line 7-8 increased from 76.1MW to 80.2MW.

TCSC is connected between the bus 4 and bus 6. The active power loss reduces to the 4.8819 MW. The Xtcsc is equal to the -0.05.

Table3
Voltage magnitude and phase angle for 9bus system with and without TCSC

Base case			TCSC at 9-8		TCSC at 7-8		TCSC at 4-6	
Ploss =5.2996			4.6323		4.7775		4.8819	
Xtcsc			-0.0400		-0.0350		-0.0500	
Bus	V (V)	δ Degree	V (V)	δ Degree	V (V)	δ Degree	V (V)	δ Degree
1	1.040	0	1.040	0	1.0400	0	1.040	0
2	1.025	9.17	1.025	10.130	1.0250	6.489	1.025	10.
3	1.025	4.63	1.025	3.5323	1.025	7.331	1.025	7.4
4	1.027	-2.2	1.0275	-2.212	1.0276	-2.2	1.026	-2.3
5	0.998	-3.98	1.0014	-3.595	1.0015	-4.8	0.996	-3.4
6	1.014	-3.7	1.0123	-4.09	1.0142	-2.7	1.026	0.2
7	1.031	.637	1.0405	4.6493	1.0335	0.971	1.031	5.3
8	1.020	0.688	1.0418	2.0378	1.0321	4.399	1.021	2.8
9	1.033	1.943	1.0267	0.8193	1.0376	4.647	1.036	4.7

Table 4
Comparison of Results

	Matlab Programming		Power World Simulator	
	Power loss (MW)	Xtcsc (pu)	Power loss (MW)	Xtcsc (pu)
Base case	5.2996	-	5.6	-
TCSC at 9-8	4.6323	-0.04	4.9	-0.04
TCSC at 7-8	4.7775	-0.035	5.4	-0.035
TCSC at 4-6	4.8819	-0.05	5.6	-0.05

Case-II: IEEE 14 Bus System

This method is extended to the IEEE 14 bus system. The SVC device is connected to the bus 14 and bus 4. TCSC device is connected between the line 12-13 and line10-11 [3].

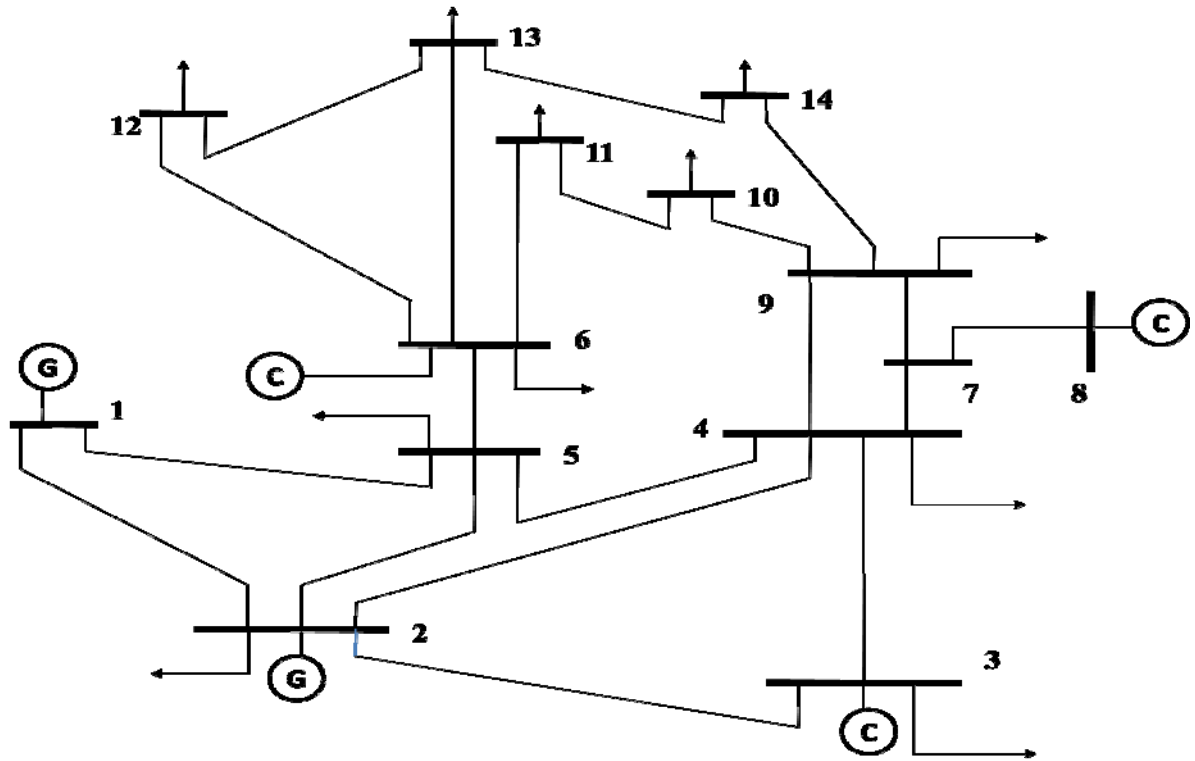

Fig 5. :IEEE 14 bus system

Table 5
Voltage magnitude and phase angle for IEEE 14bus system with and without SVC

Bus	Base Case		SVC at Bus 4		SVC at 14	
	V (V)	δ Degree	V (V)	δ Degree	V (V)	δ Degree
1	1.060	0	1.060	0	1.0600	0
2	1.045	-5.4778	1.045	-5.0035	1.0450	-4.9682
3	1.0247	-13.682	1.0100	-12.839	1.0263	-12.8400
4	1.0230	-11.464	1.0000	-10.069	1.0261	-10.3534
5	1.0282	-9.8823	1.0132	-8.7109	1.0308	-8.8944
6	1.0564	-16.813	1.0399	-14.797	1.0515	-14.8254
7	1.0379	-15.626	1.0198	-13.376	1.0379	-13.5153
8	1.0771	-15.626	1.0597	-13.376	1.0772	-13.5153
9	1.0233	-17.814	1.0067	-15.103	1.0208	-15.1867
10	1.0156	-18.730	1.0048	-15.349	1.0186	-15.4165
11	1.0317	-17.896	1.0185	-15.200	1.0313	-15.2463
12	1.0411	-17.738	1.0242	-15.702	1.0344	-15.6872
13	1.0356	-17.863	1.0189	-15.777	1.0278	-15.7027
14	1.0180	-19.081	1.0009	-16.678	1.0000	-16.3339

Table 6
Comparison of Results

	Matlab Programming		Power World Simulator	
	Power loss (MW)	Qsvc (MVar)	Power loss (MW)	Qsvc (MVar)
Base case	16.0811	-	15.4	-
SVC at bus 4	13.7587	46.4601	13.1	44.8
SVC at bus 14	13.4279	8.4664	12.7	9

Table 7
Voltage magnitude and phase angle for IEEE 14bus system with and without TCSC

Base case			TCSC between line 10-11		TCSC between line 12-13	
Ploss	16.0811		14.3240		13.3962	
Xtsc			-0.06		-0.06	
Bus	V (V)	δ Degree	V (V)	δ Degree	V (V)	δ Degree
1	1.0600	0	1.0600	0	1.0600	0
2	1.0450	-5.477	1.0170	-4.621	1.0450	-4.957
3	1.0247	-13.68	0.9929	-12.932	1.0291	-12.82
4	1.0230	-11.46	0.9895	-10.19	1.0312	-10.40
5	1.0282	-9.88	0.9984	-8.757	1.0354	-8.94
6	1.0564	-16.81	1.0058	-15.49	1.0651	-14.76
7	1.0379	-15.62	0.9720	-13.50	1.0499	-13.5
8	1.0771	-15.62	0.9610	-13.50	1.0887	-13.5
9	1.0233	-17.81	0.9709	-15.27	1.0367	-15.12
10	1.0156	-18.73	0.9759	-15.50	1.0342	-15.34
11	1.0317	-17.89	0.9667	-15.93	1.0459	-15.17
12	1.0411	-17.73	0.9894	-16.42	1.0463	-15.76
13	1.0356	-17.86	0.9839	-16.46	1.0470	-15.65
14	1.0180	-19.08	0.9645	-17.16	1.0309	-16.57

Table 8
Comparison of Results

	Matlab Programming		Power World Simulator	
	Power loss (MW)	Xtsc	Power loss (MW)	Xtsc
Base case	16.0811	-	15.4	-
TCSC at 10-11	14.3240	-0.06	12.8	-0.05
TCSC at 12-13	13.3962	-0.06	12.9	-0.05

CONCLUSION

The reactive power control and reduction of transmission loss with SVC and TCSC device is applied to IEEE 9-bus power system and IEEE 14 bus system from the result the following conclusion can be drawn,

With realization of SVC and TCSC in the power system reduces the total active power loss can be achieved. Thus improvement in voltage profile can be achieved using SVC and TCSC device. The SVC and TCSC device is used to control the power flow of the system.

REFERENCES

- [1] Kumar, G.R. Rao, R.K. Ram, S.S.T. "Power Flow Control and Transmission Loss Minimization model with TCSC and SVC for Improving System Stability and Security" Industrial and Information Systems, 2008. ICIS 2008. and the Third international Conference on Dec. 2008
- [2] Mohammad osman Hassan, S.J. Cheng, zakaria Anwar Zakaria," Steady-State Modeling of SVC and TCSC for power Flow Analysis", IMECS 2009 Vol II, March 18-20,2009, Hong Kong.
- [3] Mrinal Ranjan, B. Vedik," Optimal Location of FACTS Devices in power system by Means of Sensitivity Analysis", TECE(1) 1-9,2011.
- [4] Preecha Preedavichit, S.C. srivastava "Optimal reactive power dispatch considering FACTS Devices" electric power system reaserch 46 (1998) 251-257.
- [5] P. Kundur, Power System Stability and Control, McGraw-Hill, New York, 1994.
- [6] N.G. Hingorani, Flexible AC transmission, IEEE Spectrum, April (1993) 40-45.
- [7] D. P. Kothari, J. S. Dhillon "Power System Optimization"
- [8] Enrique Achha, Claudio R. Fuerte-Esquivel, Hugo Ambriz-Perez and Cesar Angeles Camacho "FACTS Modeling and Simulation in power Networks".
- [9] Paul M. Anderson, A. A. Fouad," Power System Control and Stability", IEEE press power engineering series,2003
- [10] K. R. C. Mamandur, R. D. Chenoweth, "Optimal control of reactive power flow for improvements in voltage profiles and for real power loss minimization" IEEE Transactions on Power Apparatus and Systems, Vol. PAS-IIO, No. 7 July 1981,page no. 3185-3194

- [11] S. Ramalyer, R. Ramachandran, S. Hariharan, New technique for optimal reactive power allocation for loss minimization in power system, IEE Proc. C 130 (4) (1983) 178–182.
- [12] J. Carpentier, Optimum power flow—a survey, Int. J. Electric. Power Energy Syst. 1 (1) (1979) 3–15.
- [13] Yoshiki Nakachi, Atsushi Kato, Hiroyuki Ukai, “Voltage / Reactive Power Control Optimization with Economy and Security using Tabu Search”
- [14] M. Khiat , Chaker , A. Go´mez Expo´ sito , J.L. Mart´ınez Ramo “Reactive power optimization and voltage control in the Western Algerian transmission system: a hybrid approach”,
- [15] Q. H. Wu, Y. J. Cao and J. Y. Wen “Optimal reactive power dispatch using an adaptive genetic algorithm