

On using PEMFC for Electrical Power Generation on More Electric Aircraft

Jenica Ileana Corcau, Liviu Dinca

Abstract—The electrical power systems of aircrafts have made serious progress in recent years because the aircrafts depend more and more on the electricity. There is a trend in the aircraft industry to replace hydraulic and pneumatic systems with electrical systems, achieving more comfort and monitoring features and enlarging the energetic efficiency. Thus, was born the concept More Electric Aircraft. In this paper is analyzed the integration of a fuel cell into the existing electrical generation and distribution systems of an aircraft. The dynamic characteristics of fuel cell systems necessitate an adaptation of the electrical power system. The architecture studied in this paper consists of a 50kW fuel cell, a dc to dc converter and several loads. The dc to dc converter is used to step down the fuel cell voltage from about 625Vdc to 28Vdc.

Keywords—Electrical power system, More Electric Aircraft, Fuel Cell, dc to dc converter

I. INTRODUCTION

THE concept of More Electric Aircraft (MEA) implies increasing use of electrical power to drive aircraft subsystems that in the conventional aircraft, have been driven by a combination of mechanical aircraft, hydraulic and pneumatic systems. The objective of the MEA is to completely replace the non-electrical power in the aircraft with electricity [1]. This idea was first applied to meet the military requirement for less overall weight of the aircraft, lower maintenance costs, higher reliability and better performance. With increased capacity of the civil aircrafts, it has been also applied into civil aircraft power systems. Recent advances in the areas of power electronics, electric drives, control electronics, and microprocessors, are already providing the impetus to improve the performance of aircraft electrical systems and their reliability. As results, the MEA concept is seen as the direction of aircraft power system technology [2]. The electrical power systems of aircrafts have made much progress in recent years because the aircrafts depend more and more on electricity. So, the voltage 28 Vdc was the classical electrical power system from 1940 s to 1950. There were one or two dc batteries to support the essential loads during an emergency occasion. The voltage 115 Vac supplies the load ac.

Jenica Ileana Corcau is with the University of Craiova, Faculty of Electrical Engineering, Romania, Craiova, 200440, Decebal, Blvd, no. 107, (phone: +40735553569; e-mail: jcorcau@elth.ucv.ro).

Liviu Dinca is with the University of Craiova, Faculty of Electrical Engineering, Romania, Craiova, 200440, Decebal, Blvd, no. 107, (phone: +40745191812; e-mail: ldinca@elth.ucv.ro).

Therefore, future aircraft power systems will employ multi-voltage level hybrid dc to ac systems. In a modern aircraft, different kinds of power electronic converters, such as ac to dc rectifiers, dc to ac inverters and dc to dc choppers are required. So, MEA electrical distribution systems are mainly in the form of multi-converter power electronic system.

The electrical system of modern aircraft is a mixed voltages system which consists of the four types of voltage: 235Vac (variable frequency), 115Vac, 28Vdc and +/- 270Vdc.

In figure 1 is presented the electrical system evolution in MEA.

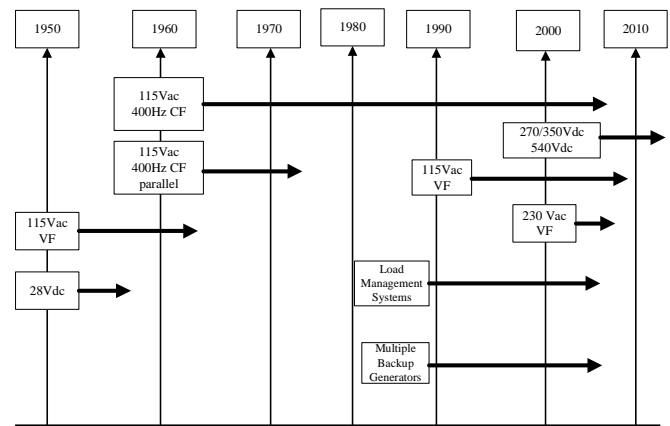

Fig. 1 Electrical system evolution [3]

A. Electric power generation in MEA

The power electronics development in the last few years reached to electrical power conversion systems on aircraft realized with power electronics. Components used are power diodes, transistors and thyristors.

In the literature are presented four generation electrical power methods on the aircraft: constant frequency system (CF) known as Integrated Drive Generator (IDG), variable speed – constant frequency system (VSCF) with DC link, variable speed – constant frequency (VSCF) with cycloconverter, variable frequency system with the frequency between 360 ÷ 800 Hz [4].

In the first case CF or IDG (fig. 2a) one use a mechanical or electrical speed converter before the electrical generator. The speed converter ensure the constant speed for the electrical generator and so the constant frequency to the output. The main disadvantage of this method is the presence of the speed converter. In most cases it is a gearbox with a relative big weight. It is well known that the weight is a critical parameter on aircraft. The gearbox reliability is another big problem of this method. The entire power generation system becomes

unreliable, expensive and cumbersome. The second method VSCF with DC link (fig. 2b) is the most used on military aircraft, but it is used also on some commercial aircraft. In this case one uses a dc generators and static electronic power converters. One obtains by this way the ac voltage with constant frequency. The method is simpler, the weight of the entire systems decrease and the reliability of the static power converters are very good.

A similar method is the VSCF with cycloconverter (fig. 2c). In this case one uses an ac generator driven with variable speed by the aircraft's engine. The ac variable frequency power is converted also by power electronic into constant frequency, constant amplitude ac power. The great advantage of this method is the improvement of the converter efficiency once the power factor decrease. For this reason one use VSCF with cycloconverters on commercial aircrafts, where are many high power consumers and the power factor may decrease in some operating conditions.

The variable frequency (VF) is a more experimental method in present (fig.2d). Following a low cost power system and low weight, one may accept in some conditions a variable frequency power system. It is considered that an aircraft with such a power system has utilitarian consumers as prevailing consumers. For example, the galley consumers don't need high performance power systems. Although, other consumers may be disturbed in this case (e.g. high power motor loads).

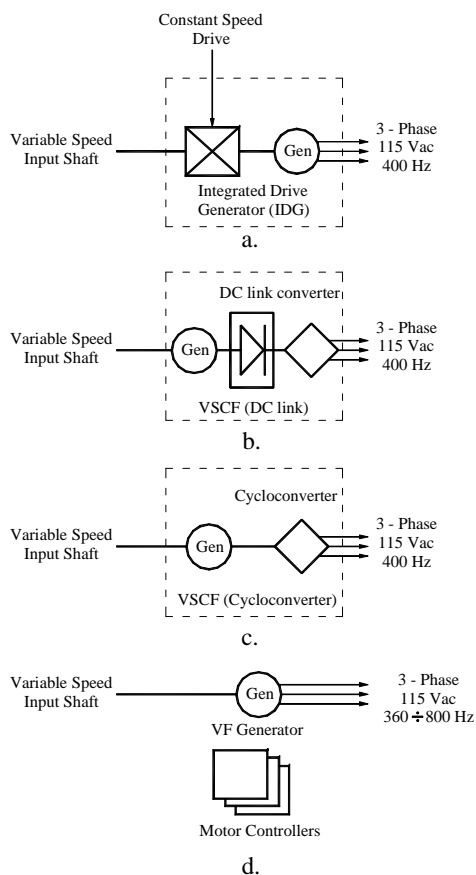

Fig. 2 Electric power generation in MEA

II. PEM FUEL CELL MODEL

Fuel cells have become increasingly important as alternative sources of power, offering the potential for drastic reduction in emissions. In recent years, the manufacturers of commercial aircrafts have realized that fuel cells may offer them several advantages (especially Boeing and Airbus) [5]-[7].

This paper focuses on integrating of polymer Electrolyte Membrane Fuel Cell (PEMFC) to the existing electrical generation. This type has, compared to other fuel cell types, a better dynamic characteristics and a higher power density. Additionally the fuel cell has to operate constantly to achieve a high durability.

The dc to dc converters are used to connect the fuel cell stacks with its variable output voltage to the bus bar. These are connected in series with stacks. Also the regulation of parallel connection can be done by the converters. The balance of power can be provided by regulation of the output voltage of the converter [7].

The architecture studied in this paper consists of 50kw fuel cell, a dc to dc converter and several loads.

Fuel cells are static energy conversion devices that convert the chemical energy of fuel directly into electrical energy. In literature are presented six categories defined as follow [6]-[10]:

- Polymer Electrolyte Fuel Cell (PEFC), also called Proton Exchange Membrane PEM, operating temperature 60-120°C, used in transportation demonstrations and small power applications, power 5-250kW;
- Alkaline Fuel Cell (AFC), operating temperature <100°C this used in space applications since 1960s;
- Phosphoric Acid Fuel Cell (PAFC), operating temperature 160-220°C, widely used in airports, hospitals and schools;
- Molten Carbonate Fuel Cell (MCFC), operating temperature 600-800°C, used in applications at limited to large stationary power plant;
- Direct Methanol Fuel cell (DMFC), operating temperature 60-120°C, used in application at portable power sources;
- Solid Oxide Fuel Cell (SOFC), operating temperature 800-1000°C, used in applications at APU on heavy duty vehicle or aircraft and high power applications.

For the majority of fuel cell systems, the overall chemical reaction directly involved in the production of electricity can be simplified to obtain [10]

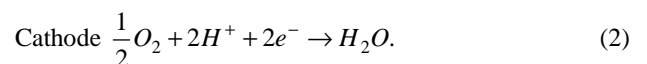

Polymer electrolyte membrane fuel cell, commonly known as proton exchange membrane (PEM) fuel cell, employs a solid polymer electrolyte. The membrane is made of Teflon-like material, and is an excellent conductor for protons, yet a great insulator for electrons. The main advantage of PEM fuel cell is its high power density, higher than any other fuel cell type, with the exception of alkaline fuel cells. There are a number of benefits from the use of solid electrolyte; lower corrosion is associated with the use of solid electrolyte, and no liquid management is required, as is the case for liquid electrolytes. The solid electrolyte allows low operating

temperatures (between 70⁰C and 90⁰C) of fuel-cell, which is beneficial in applications where a quick start is required. PEM fuel cells are preferred, due to their long life characteristic, for different application fields [10].

In this paper a PEMFC stack model from Matlab/SimPowerSystem Toolbox library was used. The Matlab/Simulink model implements a generic hydrogen fuel cell stack. The model consists within two the options: a simplified model and a detailed model. The user can switch between the models by selecting the level in the mask.

The fuel cell stack block implements a generic model parameterized to represent most popular types of fuel cell stacks fed with hydrogen and air.

The simplified model represents a particular fuel cell stack operating at nominal conditions of temperature and pressure. To show the dynamic behavior of a fuel cell stack a Matlab/SimPowerSystem model is presented. The model based on measured data of a PEM fuel cell stack [5].

The static characteristic is approximated by a polynomial method and is show by [7]

$$V(I) = -3.93710^{-5} I^3 + 0.0230 I^2 - 5.0229 I + 900$$

The technical data is shown on table 1. The stack is supplied by liquid hydrogen compressed air.

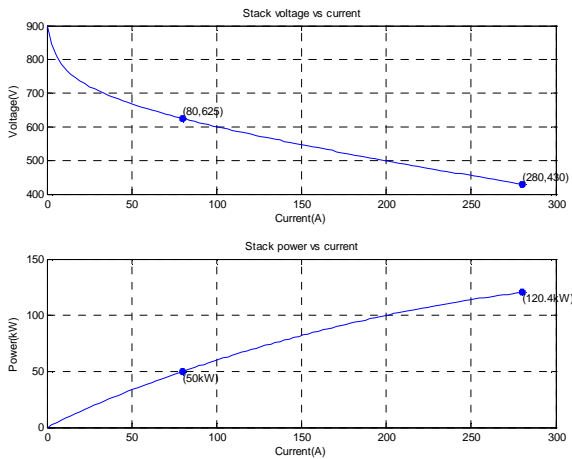

Fig. 3 The dynamic behavior of a PEMFC

TABLE I
THE TECHNICAL DATA OF FUEL CELL STACK MODELED IN
MATLAB/SIMPOWERSYSTEMS

Attribute	Value
Nominal power	50 kW
Nominal current	80 A
Nominal voltage	625 V
Maximum power	120 kW
Maximum Power Point Current	280 A
Maximum Power Point Voltage	430 V
Short circuit current	315 A
Maximum response time of air supply	2 s
Maximum response time of stack with gas oversupply	1 s
Stack Efficiency	45%

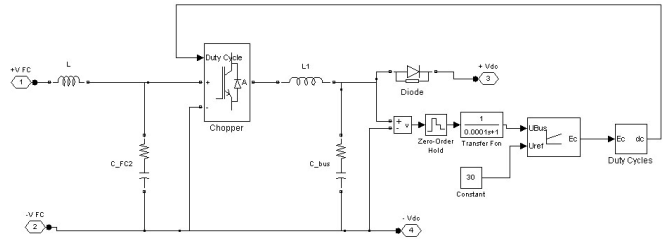

Fig. 4 The SimPowerSystems model for dc to dc converter

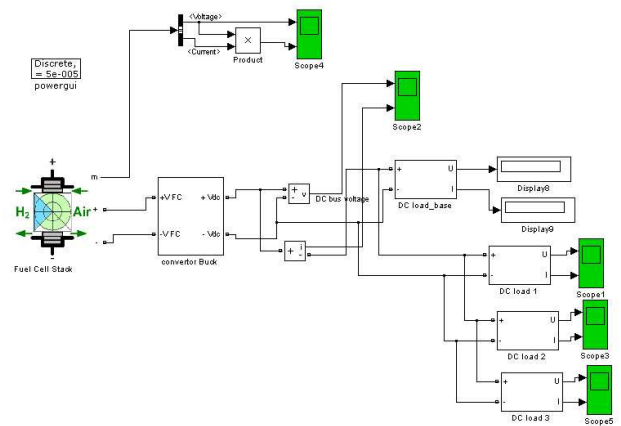

Fig. 5 The simulation model realized in Matlab/Simulink

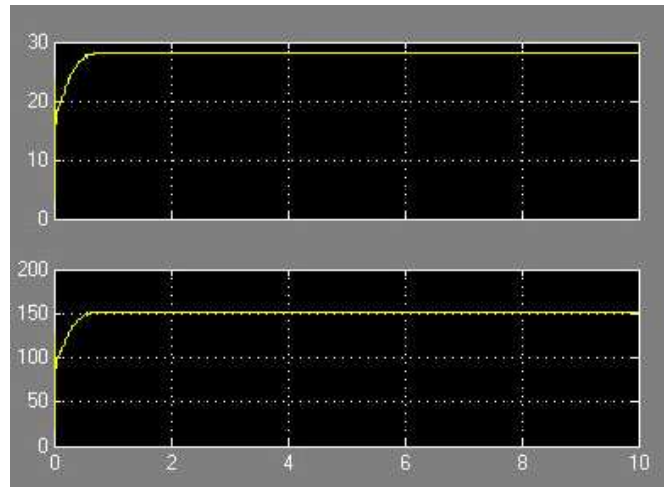

Fig. 6 Voltage and current behavior of a load 1 (4200W)

III. SIMULATION MODEL

The simulation model used in this paper is shown in figure 5. The goal of the simulation is to see if the system operates correctly. Fuel cell parameters used for the simulation can be found in table 1. The dc to dc buck converter is used to step down the fuel cell voltage from 625 Vdc to 28 Vdc. The loads were modeled as simple resistive loads. Four tasks were considered: 4200W, 3800W, and 8400W.

In figures 6 to 8 shows the simulation results. In these figures are presented the output voltage and output current for each of the three cases simulated tasks.

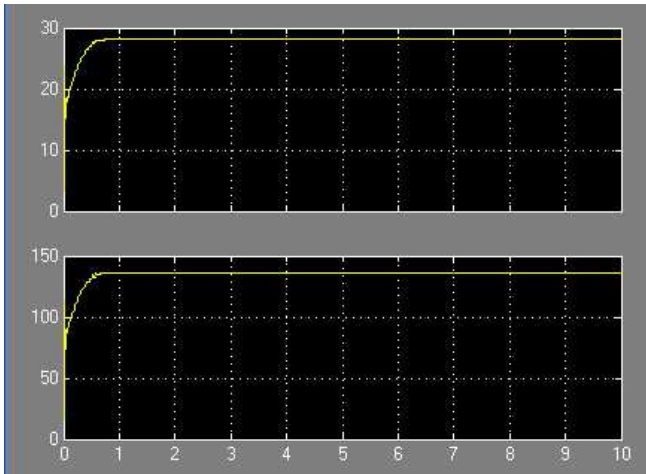

Fig. 7 Voltage and current behavior of a load 2 (3800W)

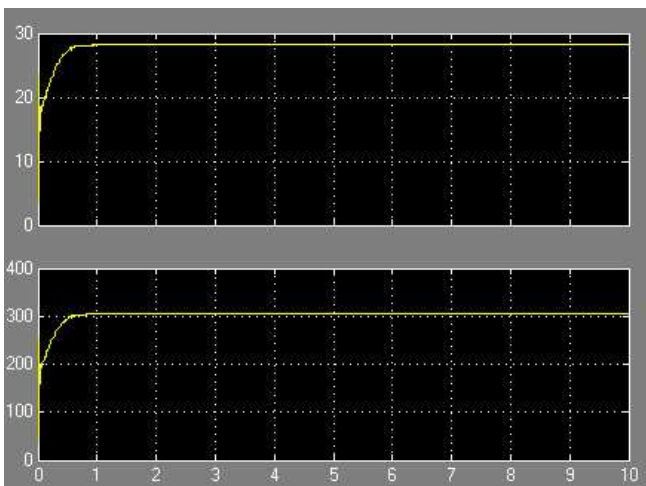

Fig. 8 Voltage and current behavior of a load 3 (8400W)

IV. CONCLUSION

A number of technology breakthroughs in recent years have rekindled the concept of a use More Electric Aircraft. Increasing use of electric power to drive aircraft subsystems is the opportunity that exists to significantly improve the aircraft power system performance, reliability and maintainability.

This paper presented the analyze of a fuel cell integration into the existing electrical generation and distribution systems of an aircraft through modeling tools. The architecture in this paper consists of a 50kW fuel cell, a dc to dc converter and is considered three loads. The simulation models for these are presented. The results confirm that this concept can deliver more power in electrical power system.

REFERENCES

- [1] Huiyu Zhu. *New Multi-Pulse Diode Rectifier Average Models for AC and DC Power Systems Studies*. Thesis of dissertation, 2005 Blacksburg, Virginia;
- [2] Emandi, A., Ehsani M. "Aircraft Power Systems: Technology, State of the Art and Future Trends". IEEE AES Systems Magazine, January 2000;
- [3] Pratt J. W., Klebanoff L. E., Munoz-Ramos K., Akhil A. A., Curgus D. B., Schenkman B. L. "Proton Exchange Membrane Fuel Cells for Electrical Power Generation On-Board Commercial Airplanes". Sandia Report, 2011;
- [4] Corcau, J., Dinca L. "Problems which imposed More-Electric-Aircraft development". ICATE 2010-10th International Conference on Applied and Theoretical Electricity, Copernicus data bases, pp. 361-365, Craiova, 2010;
- [5] J. Brombach, A Lucken, D Schulz. "Extended power delivery with fuel cell systems". Electrical systems for aircraft, railway and ship propulsion, IEEE Conference, Bologna - Italy, October 19-21, (2010);
- [6] M. Santin, A. Traverso, A. Massardo. "Technological aspects of gas turbine and fuel cell hybrid systems for aircraft: a review". The Aeronautical Journal, august (2008), vol. 112;
- [7] A. Lücken, J. Brombach, D. Schulz. "Design and protection of a high voltage dc on-board grid with integrated fuel cell system on more electric aircraft". Electrical systems for aircraft, railway and ship propulsion, IEEE Conference, Bologna - Italy, October 19-21, (2010);
- [8] M. A. Maldonado, N. M. Shah, K. J. Cleek, P. S. Walia, G. J. Korba, "Power management and distribution system for a more-electric aircraft (MADMEL) – program status," Proc. of 32nd Intersociety Energy Conversion Engineering Conference, vol. 1, pp. 274– 279, July/Aug. 1997;
- [9] Ranjit Jayabalan, "Monitoring and fault diagnosis of multiconverter power electronic systems", The University of Texas at Arlington, december 2006;
- [10] Florian Misoc, "A comparative study of DC-DC converters' effects on the output characteristics of direct ethanol fuel cells and NiCd batteries", Kansas State University 2007;
- [11] Moir, "The all-electric aircraft – major challenges", IEE Colloquium on All Electric Aircraft, digest no. 1998/260, pp. 2/1 – 2/6, June 1998;
- [12] Lungu, M. "Aircrafts' control and command using hierarchical dynamic inversion". Published in Rev. WSEAS TRANSACTIONS on SYSTEMS and CONTROL, Issue 10, Volume 5, October 2010, pag. 792 – 801. ISSN: 1991-8763.

Jenica Ileana Corcau was born in Caracal, Romania in 1975. She graduated the Faculty of Electrical Engineering Craiova in 1998 and received the Ph.D degree from Bucharest Polytechnic University, Faculty of Aerospace Engineering in 2006. Jenica Ileana Corcau is currently a Lecturer Senior in the Faculty of Electrical Engineering, Avionics Division, University of Craiova, Romania. Currently, hers field interest and working in electric power systems and dynamical and control systems. Hers areas of interest and experience in modeling and analysis of power distributions systems, robust control design of power stabilizers using fuzzy logic controller.

Liviu Dinca obtained the diplomate engineer title in aerospace engineering at the University "Politehnica" Bucharest in 1992. He performed the PhD although at the University "Politehnica" Bucharest, in 2005 in the aircraft hydraulic equipment field. In connection with this domain he has as interest domain the on board actuation systems and the electronic and computer equipment associated with it. The main contributions are in the aircraft hydraulic systems simulations and aircraft actuation systems behavior. In present he works as associate professor at the University of Craiova, Faculty of Electrical Engineering.