

Module 7 Transformer

Version 2 EE IIT, Kharagpur

Lesson

27

Auto-Transformer

Contents

27 Auto-Transformer	4
27.1 Goals of the lesson	4
27.2 Introduction	4
27.3 2-winding transformer as Autotransformer	5
27.4 Autotransformer as a single unit	6
27.5 Tick the correct answers	9
27.6 Problems	9

27.1 Goals of the lesson

In this lesson we shall learn about the working principle of another type of transformer called *autotransformer* and its uses. The differences between a *2-winding* and an *autotransformer* will be brought out with their relative advantages and disadvantages. At the end of the lesson some objective type questions and problems for solving are given.

Key Words: tapping's, conducted VA, transformed VA.

After going through this section students will be able to understand the following.

1. Constructional differences between a 2-winding transformer and an autotransformer.
2. Economic advantages/disadvantages between the two types.
3. Relative advantages/disadvantages of the two, based on technical considerations.
4. Points to be considered in order to decide whether to select a 2-winding transformer or an autotransformer.
5. The difference between an *autotransformer* and *variac* (or dimmerstat).
6. The use of a 2-winding transformer as an *autotransformer*.
7. The connection of three identical single phase transformers to be used in 3-phase system.

27.2 Introduction

So far we have considered a *2-winding* transformer as a means for changing the level of a given voltage to a desired voltage level. It may be recalled that a *2-winding* transformer has two separate magnetically coupled coils with no electrical connection between them. In this lesson we shall show that change of level of voltage can also be done quite effectively by using a single coil only. The idea is rather simple to understand. Suppose you have a single coil of 200 turns ($= N_{BC}$) wound over a iron core as shown in figure 27.1. If we apply an a.c voltage of 400 V, 50 Hz to the coil (between points B and C), voltage per turn will be $400/200 = 2$ V. If we take out a wire from one end of the coil say C and take out another wire tapped from any arbitrary point E, we would expect some voltage available between points E and C. The magnitude of the voltage will obviously be $2 \times N_{EC}$ where N_{EC} is the number of turns between points E and C. If tapping has been taken in such a way that $N_{EC} = 100$, voltage between E and C would be 200 V. Thus we have been able to change 400 V input voltage to a 200 V output voltage by using a single coil only. Such transformers having a single coil with suitable tapings are called *autotransformers*.

It is possible to connect a conventional *2-winding transformer* as an *autotransformer* or one can develop an *autotransformer* as a single unit.

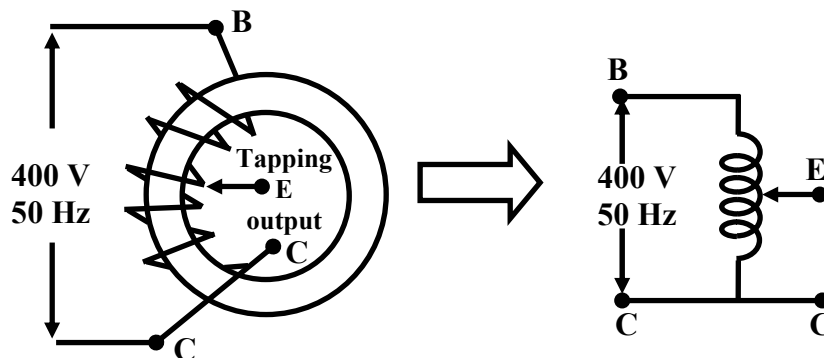

Figure 27.1: Transformer with a single coil.

27.3 2-winding transformer as Autotransformer

Suppose we have a single phase 200V/100V, 50Hz, 10kVA two winding transformer with polarity markings. Then the coils can be connected in various ways to have voltage ratios other than 2 also, as shown in figure 27.2.

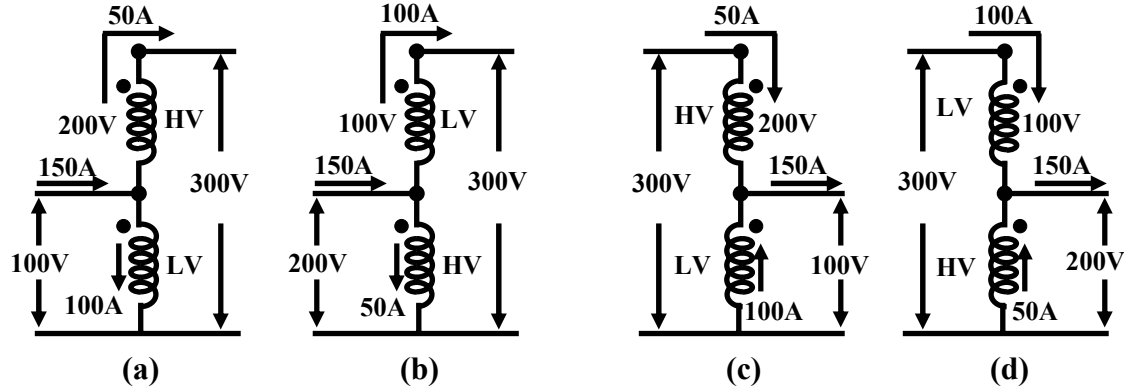

Figure 27.2: A two winding transformer connected as an autotransformer in various ways.

Let us explain the one of the connections in figure 27.2(a) in detail. Here the LV and the HV sides are connected in additive series. For rated applied voltage (100V) across the LV winding, 200V must be induced across the HV winding. So across the whole combination we shall get a voltage of 300V. Thus the input voltage is stepped up by a factor of 3 (300 V/100 V). Now how much current can be supplied to a load at 300 V? From the given rating of the transformer we know, $I_{HV \text{ rated}} = 50 \text{ A}$ and $I_{LV \text{ rated}} = 100 \text{ A}$. Therefore for safe operation of the transformer, these rated currents should not be exceeded in HV and LV coils. Since the load is in series with the HV coil, 50A current can be safely supplied. But a current of 50A in the HV demands that the LV winding current must be 100A and in a direction as shown, in order to keep the flux in the core constant. Therefore by applying KCL at the junction, the current drawn from the supply will be 150A. Obviously the kVA handled by the transformer is 30 kVA and without overloading either of the windings. It may look a bit surprising because as a two winding transformer its rating is only 10 kVA. The explanation is not far to seek. Unlike a two winding transformer, the coils here are connected *electrically*. So the kVA transferred from supply to the load side takes place both *inductively* as well as *conductively* – 10kVA being transferred inductively and remaining 20kVA transferred conductively. The other connections shown in (b), (c) and (d) of figure 27.2 can similarly explained and left to the reader to verify.

27.4 Autotransformer as a single unit

Look at the figure 27.3 where the constructional features of an auto transformer is shown. The core is constructed by taking a rectangular long strip of magnetic material (say CRGO) and rolled to give the radial thickness. Over the core, a continuous single coil is wound the free terminals of which are marked as C and A. A *carbon brush* attached to a manually rotating handle makes contact with different number of turns and brought out as a terminal, marked E. The number of turns between E & C, denoted by N_{EC} can be varied from zero to a maximum of total number of turns between A & C i.e., N_{AC} . The output voltage can be varied smoothly from zero to the value of the input voltage simply by rotating the handle in the clockwise direction.

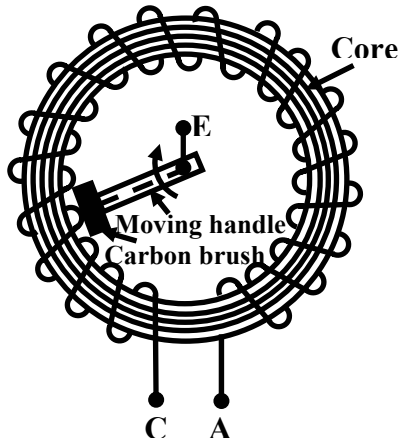

Figure 27.3: Autotransformer or Variac.

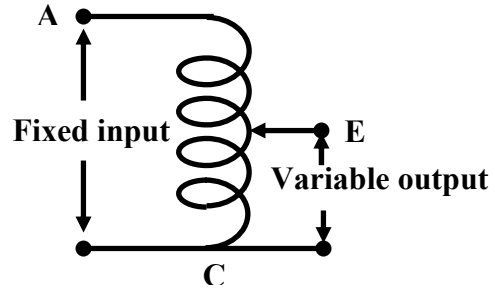

Figure 27.4: Schematic representation of autotransformer.

This type of autotransformers are commercially known as *varic* or *dimmerstat* and is an important piece of equipment in any laboratory.

Now we find that to change a given voltage V_1 to another level of voltage V_2 and to transfer a given KVA from one side to the other, we have *two choices* namely by using a *Two Winding Transformer* or by using an *Autotransformer*. There are some advantages and disadvantages associated with either of them. To understand this aspect let us compare the two types of transformers in equal terms. Let,

$$\text{Input voltage} = V_1$$

$$\text{Output voltage required across the load} = V_2$$

$$\text{Rated current to be supplied to the load} = I_2$$

$$\text{Current drawn from the supply at rated condition} = I_1$$

$$\text{KVA to be handled by both types of transformers} = V_1 I_1 = V_2 I_2$$

The above situation is pictorially shown in figures 27.5(a) and (b). Let for the two winding transformer,

For the two winding transformer:

$$\text{Primary number of turns} = N_1$$

$$\text{Secondary number of turns} = N_2$$

For the autotransformer:

$$\text{Number of turns between A \& C} = N_1$$

$$\text{Number of turns between E \& C} = N_2$$

$$\text{Therefore, number of turns between A \& E} = N_1 - N_2$$

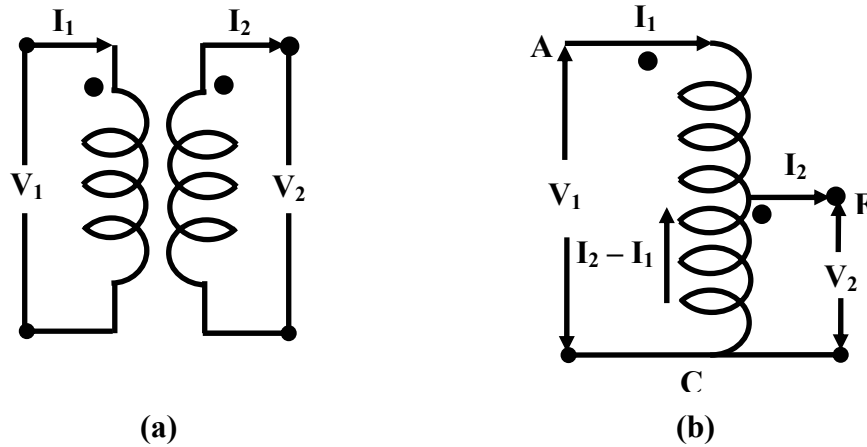

Figure 27.5: A two winding transformer and an autotransformer of same rating.

Let us now write down the mmf balance equation of the transformers.

For the two winding transformer:

$$\text{MMF balance equation is } N_1 I_1 = N_2 I_2$$

For the autotransformer:

$$\text{MMF balance equation is } (N_1 - N_2) I_1 = N_2 (I_2 - I_1)$$

$$\text{or, } N_1 I_1 = N_2 I_2$$

It may be noted that in case of an autotransformer, the portion EC is common between the primary and the secondary. At loaded condition current flowing through N_{EC} is $(I_2 - I_1)$. Therefore, compared to a two winding transformer lesser cross sectional area of the conductor in the portion EC can be chosen, thereby saving copper. We can in fact find out the ratio of amount of copper required in two types of transformers noting that the volume of copper required will be proportional to the product of current and the number of turns of a particular coil. This is because, length of copper wire is proportional to the number of turns and cross-sectional area of wire is proportional to the current value i.e.,

$$\begin{aligned} \text{Volume of copper} &\propto \text{length of the wire} \times \text{cross sectional area of copper wire} \\ &\propto N \times I \end{aligned}$$

Hence,

$$\frac{\text{Amount of copper required in an autotransformer}}{\text{Amount of copper required in a two winding transformer}} = \frac{(N_1 - N_2) I_1 + N_2 (I_2 - I_1)}{N_1 I_1 + N_2 I_2}$$

$$\text{Noting that } N_1 I_1 = N_2 I_2 = \frac{2N_1 I_1 - 2N_2 I_1}{2N_1 I_1}$$

$$= \frac{N_1 - N_2}{N_1}$$

$$= 1 - \frac{1}{a} \text{ where, } a \text{ is the turns ratio.}$$

Here we have assumed that N_1 is greater than N_2 i.e., a is greater than 1. The savings will of course be appreciable if the value of a is close to unity. For example if $a = 1.2$, copper required for autotransformer will be only 17% compared to a two winding transformer, i.e, saving will be about 83%. On the other hand, if $a = 2$, savings will be only 50%. Therefore, it is always economical to employ autotransformer where the voltage ratio change is close to unity. In fact autotransformers could be used with advantage, to connect two power systems of voltages say 11 kV and 15 kV.

Three similar single units of autotransformers could be connected as shown in the figure 27.6 to get variable balanced three phase output voltage from a fixed three phase voltage. Such connections are often used in the laboratory to start 3-phase induction motor at reduced voltage.

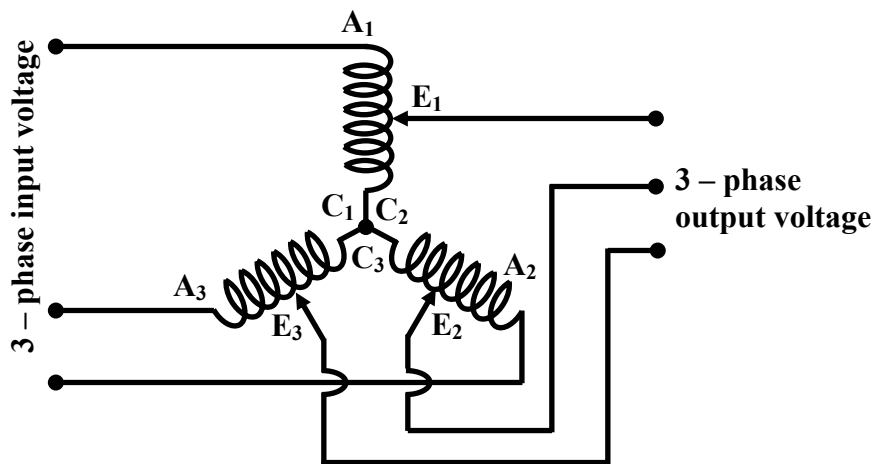

Figure 27.6: 3 – phase autotransformer connection

Apart from being economical, autotransformer has less leakage flux hence improved regulation. Copper loss in the common portion of the winding will be less, so efficiency will be slightly more. However its one major disadvantage is that it can not provide isolation between HV and LV side. In fact, due to an open circuit in the common portion between E & C, the voltage on the load side may shoot up to dangerously high voltage causing damage to equipment. This unexpected rise in the voltage on the LV side is potentially dangerous to the personnel working on the LV side.

27.5 Tick the correct answers

1. Savings of copper, in an autotransformer will be significant over a two winding transformer of same rating when the ratio of the voltages is

(A) ≈ 1 (B) $\gg 1$ (C) = 1 (D) $\ll 1$

2. 110 V, 50 Hz single phase supply is needed from a 220 V, 50 Hz source. The ratio of weights of copper needed for a *two winding* and an *autotransformer* employed for the purpose is:

- (A) 2 (B) 0.5 (C) 4 (D) 0.25

3. The two winding transformer and the autotransformer of the circuit shown in Figure 27.7 are *ideal*. The current in the section BC of the autotransformer is

- (A) 28 A from B to C (B) 12 A from C to B
 (C) 28 A from C to B (D) 12 A from B to C

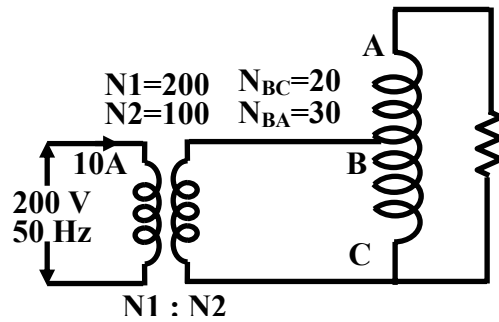

Figure 27.7:

4. A 22 kVA, 110 V/ 220 V, 50 Hz transformer is connected in such away that it steps up 110 V supply to 330 V. The maximum kVA that can be handled by the transformer is

- (A) 22 kVA (B) 33 kVA (C) 11 kVA (D) 5.5 kVA

27.6 Problems

1. The following figure 27.8 shows an ideal autotransformer with number of turns of various sections as $N_{AB} = 100$, $N_{CB} = 60$ and $N_{DB} = 80$. Calculate the current drawn from the supply and the input power factor when the supply voltage is 400V, 50Hz.

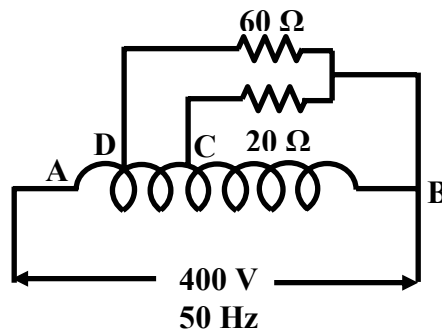

Figure 27.8:

- An ideal autotransformer steps down a 400 V, single phase voltage to 200 V, single phase voltage. Across the secondary an impedance of $(6 + j8)\Omega$ is connected. Calculate the currents in all parts of the circuit.
- Calculate the values of currents and show their directions in the various branches of a 3-phase, star connected autotransformer of ratio of 400 / 500 V and loaded with 600 kW at 0.85 lagging. Autotransformer may be considered to be ideal. It may be noted that, unless otherwise specified, voltage value of a 3-phase system corresponds to line to line voltage.
- A delta-star connected 3-phase transformer is supplied with a balanced 3-phase, 400 V supply as shown in figure 27.9. A 3-phase auto transformer is fed from the output of the 3-phase transformer. Finally the at the secondary of the autotransformer a balanced 3-phase load is connected. The per phase primary and secondary turns of both the transformers are given in figure 27.9.

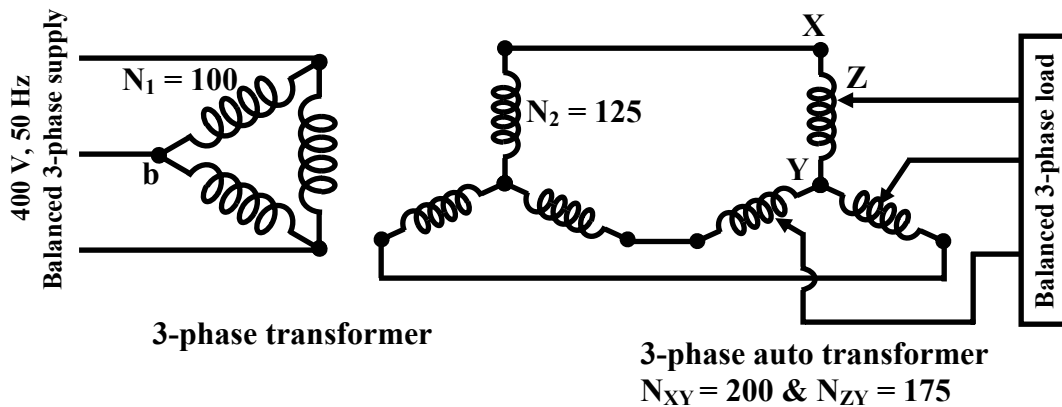

Figure 27.9:

Calculate line to line voltage at which the load receives power. If the load draws 10 A current, calculate currents (a) in the section XZ & ZY of the autotransformer and (b) line currents and coil currents of both the sides of the 3-phase, delta-star connected transformer.

Source: [http://www.nptel.ac.in/courses/Webcourse-contents/IIT%20Kharagpur/Basic%20Electrical%20Technology/pdf/L-27\(TB\)\(ET\)%20\(\(EE\)NPTEL\).pdf](http://www.nptel.ac.in/courses/Webcourse-contents/IIT%20Kharagpur/Basic%20Electrical%20Technology/pdf/L-27(TB)(ET)%20((EE)NPTEL).pdf)