

Module

11

Narrowband And Broadband ISDN

OBJECTIVE

General

This lesson is focused on giving the reader the concept and definition of Integrated Services Digital Network.

Specific

On completion of this lesson, the learner shall be able to

1. Define ISDN.
2. Identify the ISDN Services.
3. Describe the ISDN system architecture.

11.0 INTRODUCTION

The public circuit-switched telephone system has been the primary telecommunication infrastructure for more than a century. This system is inadequate for modern communication needs. So in 1984, CCITT decided to build a new fully digital circuit switched telephone system. This new system called ISDN (Integrated Services Digital Network) has integration of voice and data services as its primary goal.

Lesson

36

ISDN: Data Rates, Access Channels Types

ISDN stands for Integrated Services Digital Network. It was first introduced by NEC in Japan. Their basic purpose was integration of traditionally different computer and communication (C&C) services into a single one. The integration basically means incorporation of three types of services:

Voice (telephone)

Data (internet)

Entertainment (TV)

The integration should be most comfortably and efficiently done in digital domain, so the switching, multiplexing, signaling and transmission, everything should be digital. It was first named integrated digital network (IDN), which received lukewarm response as only the enterprises, not the general public, realized the potential behind that acronym. Later on it was named ISDN which more clearly states the idea (of integrating different services) behind it.

 *INTERNET INCLUDES VOIP, TELEPHONY-OVER-IP, AND VIDEO-OVER-IP, BUT QOS WAS NOT MAINTAINED.*

Later on, entertainment service providers started providing data service with cable modems. It has been very rare, though.

ISDN SERVICES

The key ISDN services, from the very beginning has been the voice service, although with many enhanced features. One ISDN feature is telephones with multiple buttons for instant call setup to arbitrary telephones anywhere in the world. Another feature is the display of caller's telephone number, name and address during ringing. A more sophisticated version of this feature allows the telephone to be connected to a computer so that the caller's database is displayed on the screen as the call comes in. Other advanced voice services include call forwarding and conference calls worldwide. Advanced non-voice services are remote electricity meter reading, and on-line medical, burglar, and smoke alarms that automatically call the hospital, police, or the fire brigade, respectively, and give their addresses to speed up responses.

The cost of ISDN is accounted to the CPE interface and the service itself, so only the corporate users welcome it.

ISDN SYSTEM ARCHITECTURE

The key idea behind ISDN is the digital bit pipe, a conceptual pipe between the customer and the carrier through which bits flow. Whether the bits originated from a digital telephone, a digital terminal, a digital facsimile machine, or some other device is irrelevant. All that matters is that bits can flow through the pipe in both directions. The digital bit pipe can, and normally does, support multiple independent channels by time division multiplexing of the bit streams. The exact format of the bit stream and its multiplexing is a carefully defined part of the interface specifications for the digital bit pipe. Two principal standards for the bit pipe have been developed, a low bandwidth standard for home use and a higher bandwidth standard for business use that supports multiple channels that are identical to the home use channels. Furthermore, businesses may have multiple bit pipes if they need additional capacity beyond what the standard business pipe can provide. The carrier places a network terminating device (NT1), on the customer's premises and connects it to the ISDN exchange in the carrier's office, several kilometers away, using the twisted pair that was previously used to connect to the telephone. The NT1 box has a connector on it into which a passive bus cable can be inserted. Up to eight ISDN telephones, terminals, alarms, and other devices can be connected to the cable, similar to the way devices are connected to a LAN. From the customer's point of view, the network boundary is the connector on NT1.

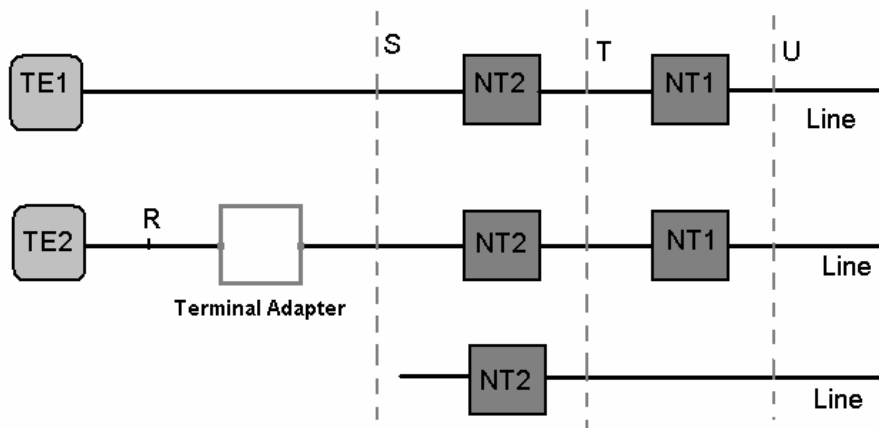

For large businesses it is common to have more telephone conversations going on simultaneously than the bus can handle. Therefore, another device, NT2, called a PBX, connected to NT1 and providing the real interface for telephones, terminals and other equipment. An ISDN PBX is not very different from an ISDN switch.

Objective Questions

36.01 Who started ISDN first?

36.02 ISDN integrates _____, _____ & _____ services.

36.03 Network terminating device _____ is called a PBX

Subjective Questions

36.11 What is the idea behind ISDN?

36.12 What are the different ISDN services?

36.13 Describe the ISDN system architecture.

Level 2 Questions

36.21

Source: <http://nptel.ac.in/courses/Webcourse-contents/IIT%20Kharagpur/Communication%20network/pdf/11.1%20Lesson%2036.pdf>