

## Lesson

## 7

---

# Data Communications Networking

---

The late 20th century has become known as the 'information age'. It would be impossible to conduct modern day businesses without the use of communication technologies such as the telephone, fax machine and computer communications networks. Communications and computer technology have become linked, resulting in *telecommunications*, the transmission of data of all kinds (text, graphics, sound and video) over different communication channels such as public telephone lines, private cables, microwave and satellite.

## **Definitions of networks**

*"A collection of entities wanting to share and have a conversation"*  
*"The exchange of messages, information or data through physical sources"*  
*"Resources or facilities that make that conversation"*

## **The Internet**

The Internet is the largest wide area network in the world. It is not a single network, but a collection of thousands of computer networks throughout the world. These linked networks are of two types:

- LAN (Local Area Network), covering an office block or University campus, for example;
- WAN (Wide Area Network) connecting computers over a wide geographical area, even over several countries.

All LANs and some WANs are owned by individual organisations.

Some WANs act as service providers, and members of the public or businesses can join these networks for a monthly charge.

There is no central authority or governing body running the Internet; it initially started with 4 computers in 1969 and grew over the next ten years to connect 200 computers in military and research establishments in the US.

Today there are millions of host computers, any of which could be holding the information you are looking for!

## **The World Wide Web**

The Web is a collection of pages stored on computers throughout the world, and joined by *hypertext* links.

A hypertext link enables you to click on a word or graphic, and be taken automatically to the related Web page.

It is the fastest-growing part of the Internet, owing much of its popularity to Web-browsing software such as Internet Explorer.

## Online information services

Hundreds of companies such as Yahoo, AOL, MSN provide online information services, enabling subscribers to gain access to the latest news, share prices, weather and sport as well as providing services such as home banking or shopping, education and entertainment and access to thousands of online databases all over the world.

## Electronic bulletin boards

Electronic bulletin boards are Internet sites for groups of people with similar interests to exchange information and discuss issues.

Bulletin boards are used by thousands of different user groups from University 'Open Learning' providers and software manufacturers user groups to less savoury groups interested in terrorist activities or paedophilias!

## Intranets

An Intranet is a company-wide network run along the lines of the World Wide Web, making it possible to share documents, databases and applications.

Intranets have the potential to revolutionise the way that organisations share information internally, just as the Internet will revolutionise the way that businesses communicate with external suppliers, customers and consultants.

The software to implement Intranets is already available. The latest Microsoft Office suite will let you surf Word and Excel documents, reading them in a local Web site just as if they had been produced by a Web page designer.

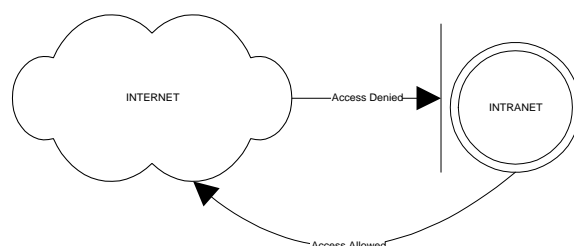

## Electronic Mail (E-mail)

E-mail systems allow you to send memos, letters and files containing data of all types from your computer to any other computer with an e-mail address and a modem.

E-mail has many advantages over both ordinary mail and the telephone. For example:

- A message can be sent anywhere in the world at the price of a local call, without having to leave your desk;
- The same message can be sent simultaneously to a group of people;
- The message will arrive in at most a few hours, and can be picked up the next time the recipient looks at their e-mail;
- It is very easy to send a reply to an e-mail as soon as it is received, using a 'Reply' button;
- Long files including video, sound and graphics can be sent automatically when the cheap rate starts after 6pm, (or especially between Midnight Friday and Midnight Sunday).
- Graphics and text can be electronically transmitted and placed in a document by the recipient.

## Hardware required to access the Internet

The basic hardware needed to set up online communications is:

- a computer
- a modem
- a telephone line.

The overall speed of online communication is governed by the speed of the modem and the speed of the communications link.

An ordinary telephone line is the cheapest but not the fastest link. An ISDN line has a greater bandwidth and will send data much faster.

### Modem

A modem (MOdulator/DEModulator) converts the data from your computer from digital form (O's and I's) into analogue or wave form so that it can be sent over the telephone line. This is because the telephone line was originally designed for speech.

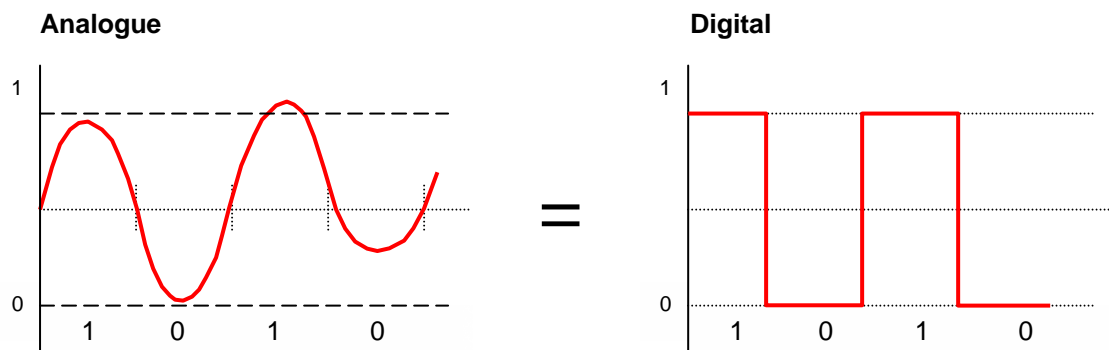

### Functions of a Modem

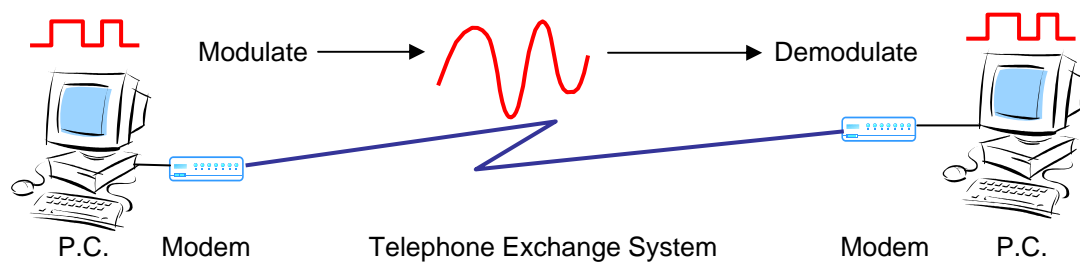

Modems typically transmit data at rates of between 28,800 bps (bits per second) and 56,600bps. A second modem at the receiving end translates the analogue signal back into digital form.

Many computers come equipped with an internal modem card in one of the free expansion slots inside the computer.

The Internet has opened a wealth of benefits from sending e-mails through to order your shopping online using desktop p.c.'s and recent mobile phone technology.

Rate at which data is transmitted is measured in **baud** (after baudot). **One baud** is equivalent to **1 bit per second**. Remember a bit is either a 1 or 0 (an electrical current or no electrical current).

The baud rate over a typical Ethernet LAN is around 10,000,000 and a typical modem would be 56,000!

## Software and services required to access the Internet

To connect to the Internet you need to sign up with an Internet Service Provider (ISP) who will supply you with a user account on a host computer and a complete software package that includes:

- A browser which enables you to download and view pages from the World Wide Web;
  - Communications software which allows your computer to transmit and receive data using the Internet TCP/IP communications protocol
  - An e-mail package to enable you to send and receive e-mails;
  - A newsreader which you use to read and post messages to the Usenet groups;
  - An FTP client which you can use to download and upload files and software.
- Some users may want to install filtering software which blocks access to certain sites and let you set times during which the net can or cannot be used. (The College has done this.)

## Telephones

It seems incredible that only a decade or so ago, mobile phones were almost unknown. In little more than a decade, the mobile phone has changed from a “verbal” communication tool to a more vital piece of kit.

### Facsimile transmission (Fax)

Fax machines are regarded as indispensable by even the smallest business and have played a large part in speeding up business transactions.

A fax machine scans and digitises images (text or graphics) on a page and transmits them in analogue form over a telephone line to another fax machine, which then reproduces a copy of the image on a piece of paper.

### Voice mail

Voice mail is a more sophisticated version of the telephone answering machine. A voice mail system can act as an automated switchboard so that when you dial a company number, you may hear a message along the lines of ‘Hello — this is the Customer Service Department of whoever. If you would like information on new services, press 1. If you have a query about your bill, press 2. For other information, press 3.’

A voice mail system also allows you to leave a recorded message for someone who is absent from the office. The recipient can then save it, delete it or forward it to someone else on another extension. Voice mails are also available on mobile phone networks.

## Teleconferencing

Teleconferencing allows people in different physical locations to exchange ideas and information interactively using either the telephone or e-mail.

A more advanced form of teleconferencing is videoconferencing, which allows participants to see and hear one another.



A videoconferencing system includes

- video cameras,
- special microphones
- large television monitors
- a computer with a special device called a *codec* that can convert analogue video images and sound waves into digital signals and compress them for transfer over digital telephone lines. (An ISDN — Integrated Services Digital Network line with a high bandwidth is required to transmit video.)

At the other end, another computer reconverts the digital signals to analogue for displaying on the receiving monitor.

Such systems are familiar from television programmes in which people on the other side of the Atlantic are interviewed from a studio in London, for example.

Microcomputer-based desktop videoconferencing systems are also available, where users can see each other and simultaneously work on the same document.

Numerous organisations offer many facilities to attract customers, benefits such as :-

### **ReadyConnect**

Make audio conference calls without advance reservations or operator assistance.

### **ActionCall**

Conduct an effective, high-level audio conference call with full operator support.

### **Passcode**

For a secured audio conference, access can be limited to select participants by issuing a passcode.

### **Worldwide Participation**

Conference via a video monitor to participants in worldwide offices.

### **Audio & Video Presentation**

Stream your audio or video message over the Internet to participants for an effective conference presentation.

### **ActionData**

Share documentation or present slides over the web with your audience while conducting an audio conference.

## Modes of Transmission

There are only three type of transmissions possible.

### Simplex

This is when transmission or a conversation can only take place in one direction. For example person A can speak to Person B, but person B can not speak back! This type of transmission is commonly used where sensors play a crucial part in the operation of a system, for example an heating system needs to maintain its pre-set temperature by constantly receiving information from the temperature sensor.

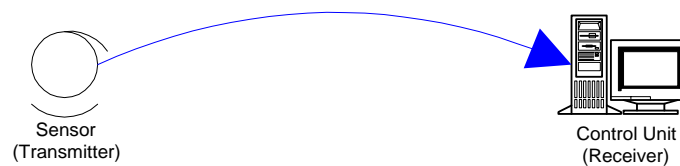

### Half Duplex

When transmission takes place in both directions but not simultaneously. This type of transmission is commonly used between a central computer and terminal. Another example would be between a PC and printer; the process known as “Handshaking”, when the PC sends a signal to the printer, asking if it is ready to receive information, the printer in turn replies with an acknowledgement. Alternatively if no signal is sent or an error signal is sent, the PC acknowledges this as a problem and, hence displays an error on the screen.

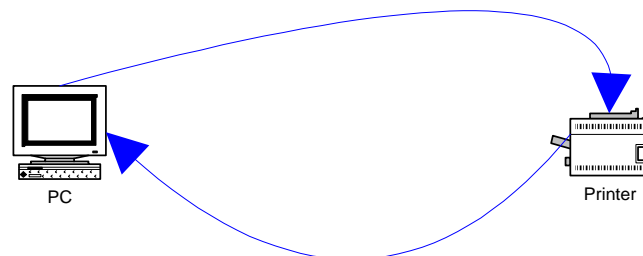

### Full Duplex

Transmission takes place both ways, simultaneously! This is suitable for interactive computer applications such as IRC (Interactive Relay Chat).

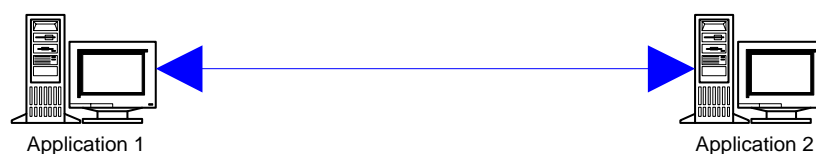

## Asynchronous & Synchronous Transmission

**Asynchronous transmission** entails one character to be transmitted at a time; each character is preceded by a start bit and followed by a stop bit. This type of transmission is usually used by PCs, and is fast and economical for relatively small amounts of data.

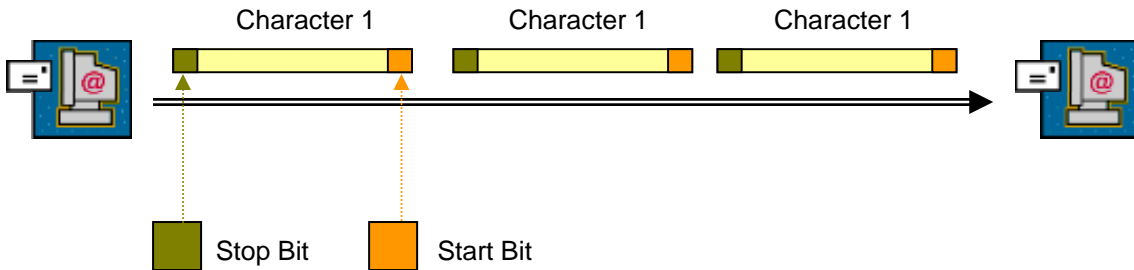

**Synchronous transmission** mode is when timing signals (usually the computer's internal clock) control the rate of transmission hence no need for start and stop bits to accompany each character. Mainframe computers usually use asynchronous transmission. It is less error-prone than asynchronous transmission.

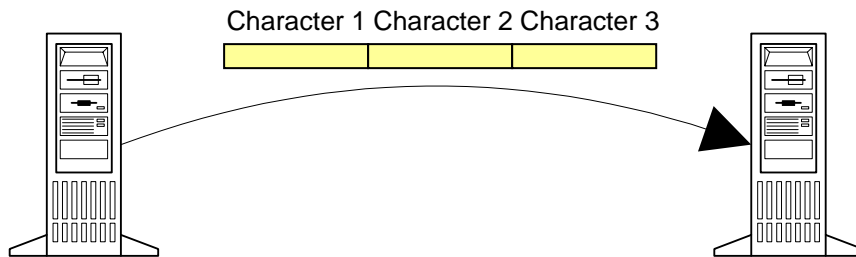

It is a necessity that both machines have reasonably same frequencies E.g.

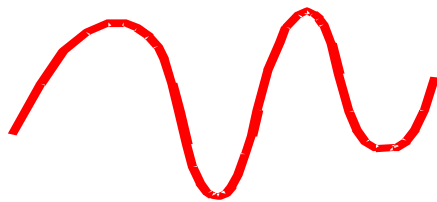

**Low Frequency**

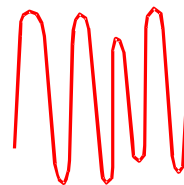

**High Frequency**

**Data Transmission** from one point to another is either transmitted in parallel or in serial. This is dependant on the type of carrier or media used. Serial transmission only requires a single "wire" or line where as parallel transmission will require more for example 8. Following Diagram illustrates the Conversion of Serial data to Parallel.

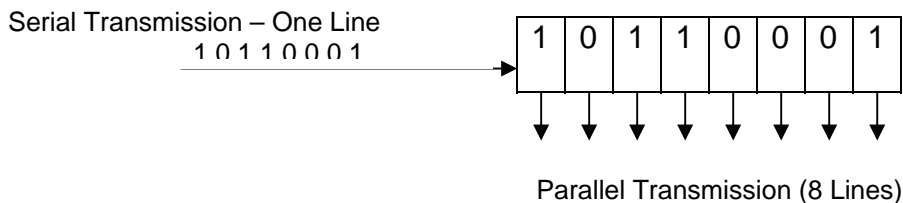

## LAN (Local Area Networks)

Local Area Networks (LAN) is a network of computers confined to a relatively small area. It is generally limited to a geographic area such as a writing lab, school, or building. Rarely are LAN computers more than a mile apart!

### Components Required to Set Up LAN

- Workstations (PC's or terminals)
- File Server (Disk server – Special PC where shared software resources are stored, including network software.
- Cabling and connection hardware – includes cable linking computers together and interface cards inserted in each computer.

### Other Types of Servers

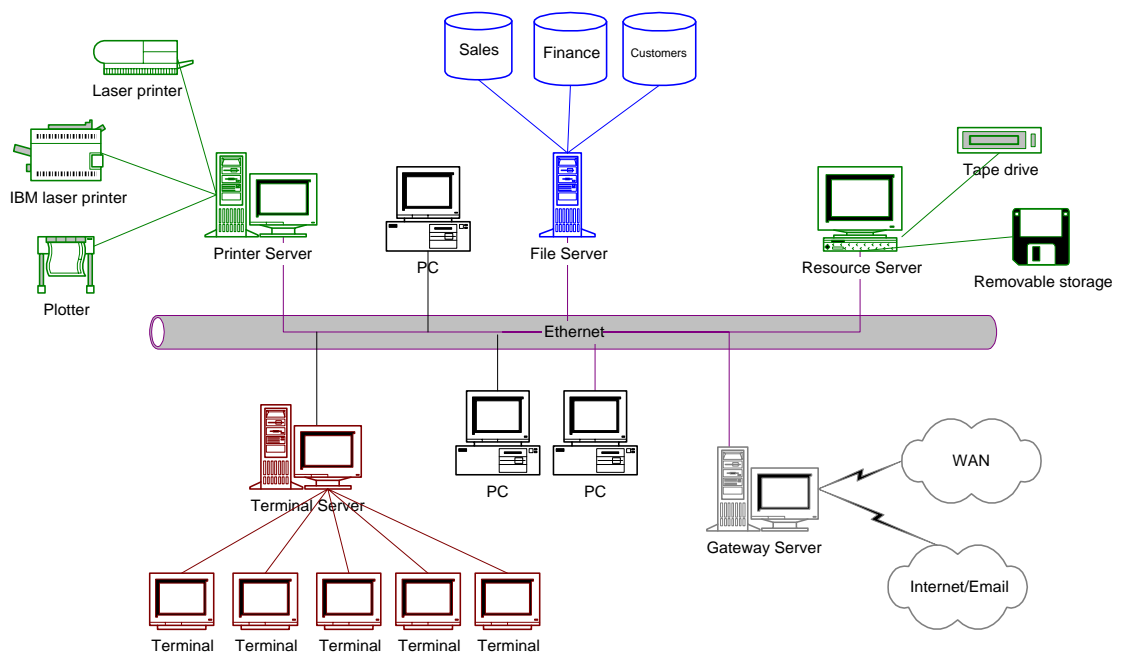

### Important Issues Relating to LAN Functionalities

- Group Productivity
- Simplicity
- Resource Allocation
- Standardized Access
- File Sharing
- Data Transfer
- Transfer Speeds
- Resource Sharing
- Greater Efficiency
- Transfer Speeds, Data Transfer

### Disadvantages of LAN

- If a file server goes down data/programs become unavailable.
- Additional measures must be taken to protect data held centrally (user names, passwords, encryption).
- Vulnerability to viruses.



**WAN (Wide Area Networks)**

Wide Area Networks (WANs) work on a larger scale, possible globally. Computers linked over large geographical areas; such as Seattle and London allow information to be shared and communicated between sites. Dedicated transoceanic cabling or satellite uplinks interconnect this type of network.

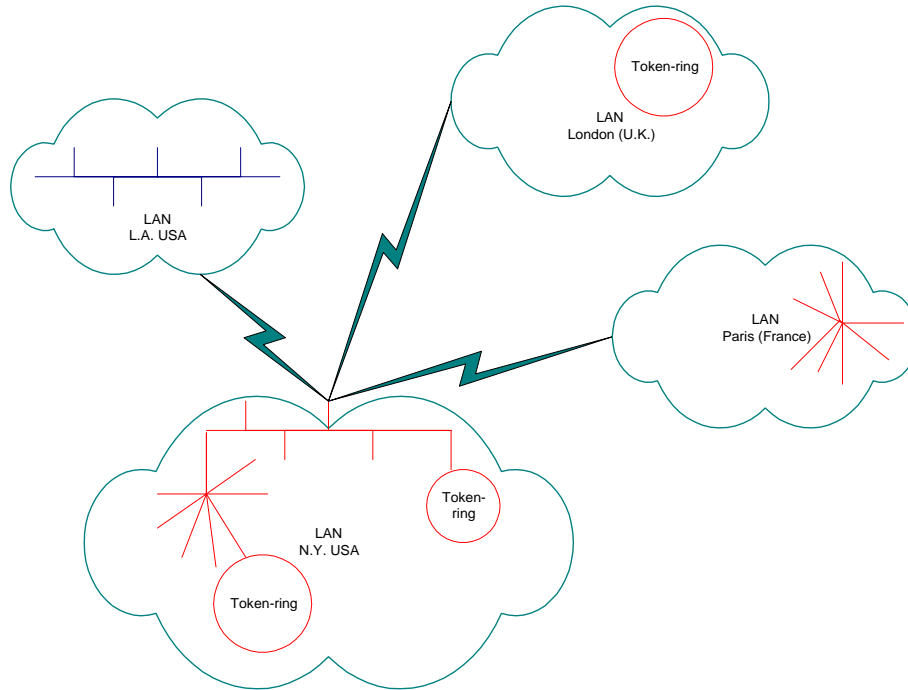

**WAP (Wireless Application Protocol)**

Wireless Application Protocol (WAP) is a new technology that allows people with mobile phones or similar devices to access the internet. WAP allows users to access bank account information, make transactions, check up to date share prices, as well as perform online shopping.

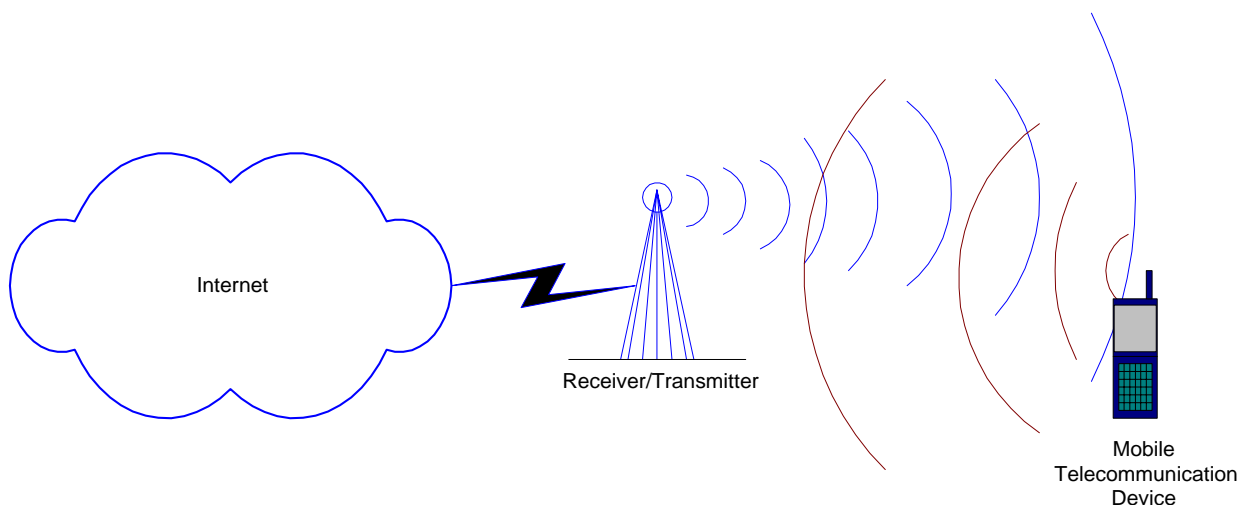

### MAN's (Metropolitan Area Networks) (Fiber Optics)

Fibre Optics allow high rates of transmission (up to 1 Billion bits/sec) plus have no effect from electromagnetic interference. MAN's use such kind of technology and can have lengths of 100km.

They are similar to token ring (refer later) but work on a more complex dual ring system which is prone to problems such as a break in the fiber optic.

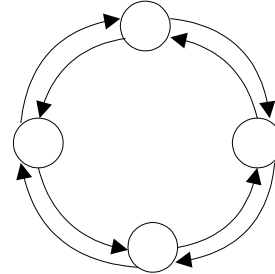

Fibre optics work on the principle of transmitting light which is interpreted as signals (Bits), this is achieved by guiding the light pulses from source to destination. Glass fibres are woven together to form the basis of the cable. Diagram below shows how light is bounced off the walls of a fiber optics; this is achieved with laser and light emitting diodes.

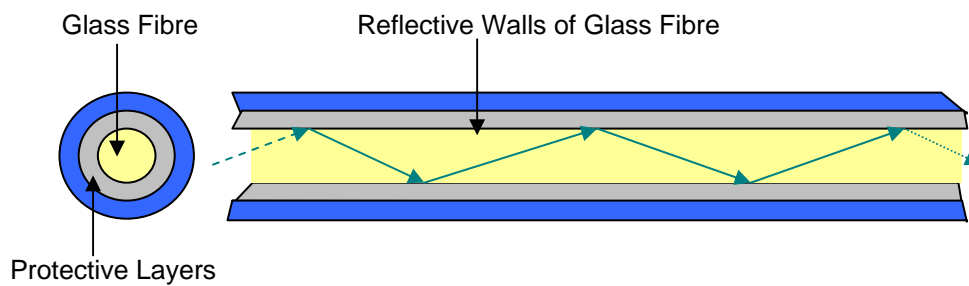

## Other Communication Media

As mentioned above Fiber Optics is one form of media used in transmitting data/information from source to destination; other forms of media are:-

**Coaxial Cable** is a high quality, well insulated cable capable of transmitting data over short distances. It is most commonly used in LAN's, found to be cheap and simple to connect.

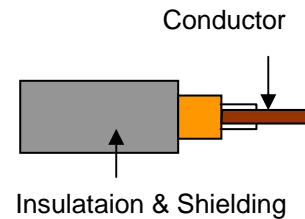

**UTP (Unshielded Twisted Pair)** is a copper cable used in much of the telephone networks. Unless shielded it can be a security risk since it radiates to its surroundings! It is cheap and easy to install.

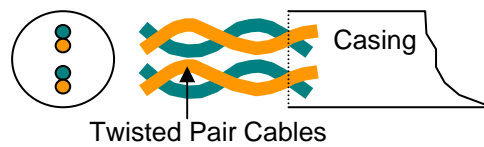

**Communication Satellite** allow data/information to be bounced off the satellites in geo-synchronous orbit over 20,000 miles above earth (geo-synchronous – rotating at the same speed as earth, hence stationary relative to the earth)



**Microwave** is similar to radio waves. Due to the earth's curvature and as microwaves travel in straight lines, microwave stations can not be 30 miles apart. This is one key reason why you may experience no reception on your cell phones; you may be out of reach from a transmitter /receiver.

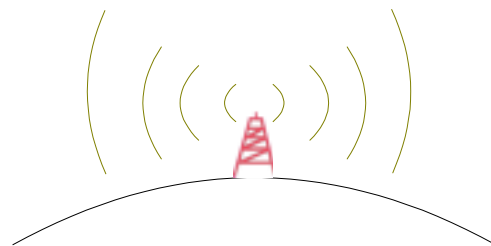

Hence the need for many receivers/transmitters in a small geographical area (Cells).

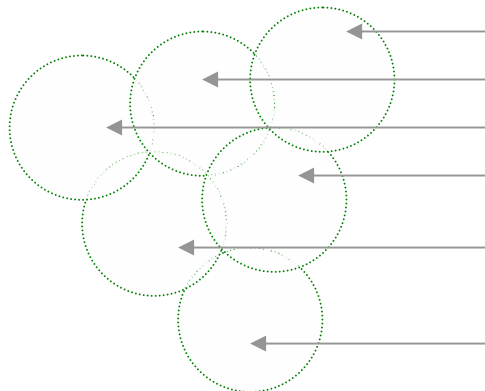

Transmitters / Receivers are placed in each cell (i.e. within a 30 mile radius)

## Network Topologies

A number of different topologies or rather physical layouts of networks exist; Star, Bus, Ring and a combination of all three will be discussed in this section.

### Star Topology

Each node in a star network is connected to a central computer, which controls the network. Signals travel from to the server to each station along each cable. A polling system is usually used; the file sensor checks each station in turn to see if it has a signal to send, such signals are then handled as they are received.

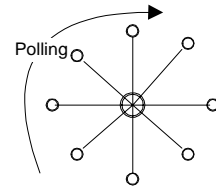

Example of a typical Star topology

A **Concentrator** or **Hub** is a device that provides a central connection point for cables from workstations, servers, and peripherals.

Hubs are multislot concentrators into which can be plugged a number of multi-port cards to provide additional access as the network grows in size

Usually configured with 8, 12, or 24 RJ-45 ports

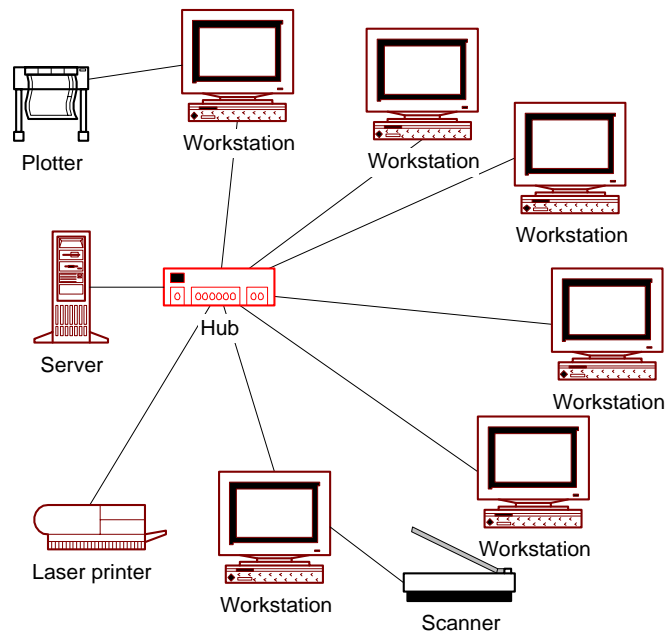

### Advantages

- If one cable fails, other stations are not effected
- Consistent performance even when the network is heavily used
- Reliable
- No problem of data collision as each station has its own network
- New stations may be included with the addition of new cables
- Easy to install and wire.
- No disruptions to the network then connecting or removing devices.
- Easy to detect faults and to remove parts.

### Disadvantages

- Generally, costly to install due to the amount of cabling required and hub(s).
- If the hub or concentrator fails, nodes attached are disabled.

## Bus Topology

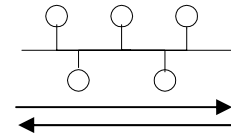

All devices share a single cable, information is transmitted in either direction from any PC to another. Bus topology employs a popular system called Ethernet that uses **CSMA-CD** – **carrier sense multiple access collision detection**. The purpose of this is to prevent two stations transmitting at the same time which may cause a collision. For example Workstation 1 is about to transmit to Workstation 2 and Work station 4 is about to transmit to Work station 1 – the consequences of this action will result in a collision hence the “breakdown” of the LAN!

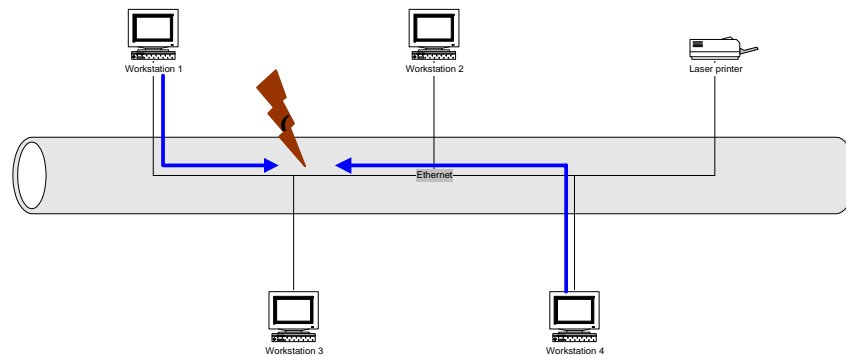

CSMA-CD overcomes this problem by checking if the channel prior to transmitting. If it is found to be busy the station will need to wait. During transmission the node (workstation) listens for other nodes beginning to make transmission. If in the likely hood messages do collide, both stations abort and wait for a random period of time before continuing.

This system works well if channels are not heavily used or loaded. Alternatively, if traffic increases due to many users and hard disk usage, the whole system can come to a stand still.

### Advantages

- Simple and inexpensive to install, very limited cabling is required.
- Easy to include additional stations without disruption of the network.

### Disadvantages

- The whole network is dependant on a single cable, hence if the cable fails the whole system fails too
- Difficult to locate cable failure.
- Network performance is directly related to traffic.
- Not meant to be used as a stand-alone solution in a large building.
- Terminators are required at both ends of the backbone cable along with T-Junctions at each workstation

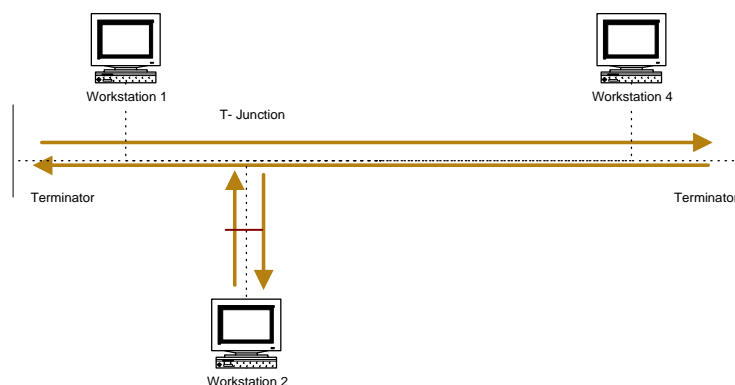

## Ring Topology

A series of stations are connected together; there is no central controlling computer but file / printer server(s) are present.

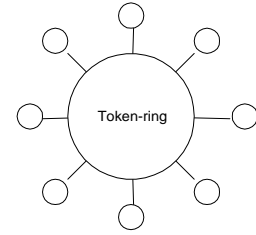

Each computer has the capability of communicating with other computers. Messages are specifically addressed to destination computers. A “token ring” system is used which allows “message tokens” to be passed from node to node.

Each node has a designated time period to either remove the message or add a message to the token.

The token comprises of the destination address, message and which node the sent the message.

Tokens always travel in one direction, thus preventing collision.

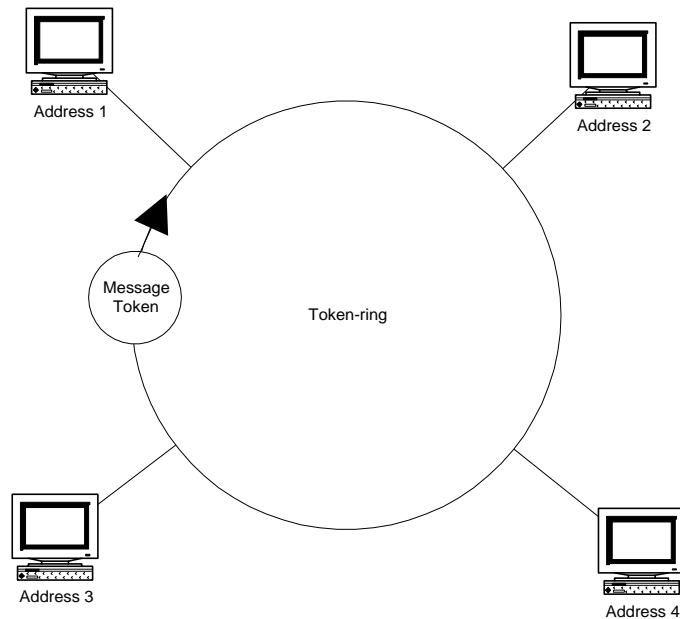

### Advantages

- No collision is possible due to the token system.
- Performance is effected if heavy load is encountered.

### Disadvantages

- Network is disrupted if additional stations are added (the system must be updated in terms of new addresses being added).
- A break in the network will stop the system.

## Summary

### WANS Versus LANS

#### **WAN**

- Communication equipment separated by large distances.
- Lines may be rented or leased by communications provider
- Speed of transmission is reduced relative to distance.

#### **LAN**

- Limited geographical areas (1 to 10 km)
- Owned and administered by the user group (Network administrator(s))
- Less than 1000 users.
- A wide choice of media and topologies are available.

### Future of Data Communication Networking

## Exercises

- 1 Distinguish clearly between half-duplex and full duplex in the context of data transmission.

### **Suggested answer**

Half-duplex mode supports communications in both directions but not at the same time.

It is suitable for data transmission between a computer and dumb terminals.

Full-duplex mode allows communication in both directions at the same time and is suitable for interactive systems.

1. A multi-national company is considering the use of 'teleconferencing'.
- What is meant by the term 'teleconferencing'. (3)
  - List the minimum facilities required to enable 'teleconferencing' to take place. (4)
  - Discuss two advantages and two disadvantages to the firm of using 'teleconferencing' as compared to traditional methods. (4)
3. A large company has introduced a communication system which includes electronic mail. This system will be used for both internal use within the company and for external links to other organisations.
- Describe two features of an electronic mail system which may encourage its use for internal communication between colleagues. (2)
  - Contrast the use of an electronic mail system with each of fax and the telephone. (6)
  - Describe two functions the communication system might have, other than the creation and reception of messages. (4)
  - List four advantages of the use of email over ordinary postal mail? (4)
4. A company specialises in organising international conferences for doctors. The company has decided to make use of the Internet for advertising and organising the conferences.
- State, with reasons, the hardware that the company would need, in addition to their PC and printer, in order to connect to the Internet. (4)
  - State the purpose of the following software when used for the Internet:
    - Browser
    - Editor
    - E-mail software
  - Explain three potential advantages for this company of using the Internet as opposed to conventional mail/telephone systems. (6)
5. Facsimile and computer based electronic mailing systems are different forms of message systems.
- For each of these systems, describe two of the facilities offered. (4)
  - Discuss the relative strengths and weaknesses of each of these systems.
6. What benefits do you think LAN have introduced into organizations, and what drawbacks are could businesses/people face?



7. A local area network (LAN) is a collection of computers and peripherals linked by cables for the use of a single organisation or company. Most LANs are confined to a single office block or commercial site. State three advantages of a LAN compared with the use of a collection of stand-alone microcomputers.
8. A newspaper has a multi-access system, which supports 200 terminals. As the number of user's increase, there is a gradual degradation of performance, which rapidly worsens as the number of users approaches 150.
  - (a) Explain the gradual degradation of performance.
  - (b) Explain the rapid worsening of performance and suggest how this could be remedied.
9. A college currently uses two separate local area networks, one for administration and one for teaching. Both networks use a bus topology.
  - (a) The administration network consists of 12 workstations and a dedicated file server. One of the workstations also acts as a printer server.
    - (i) Explain the function of the printer server and the file server.
    - (ii) State two possible disadvantages of using a workstation as a printer server.
  - (b) Ring and Star are common topologies for local area networks.

Describe these topologies; using *clearly labelled diagrams* to illustrate your answer.