

Kinematics analysis for five DOF Fresh Fruit Bunch harvester

Helena Anusia James Jayaselan, Wan Ishak Wan Ismail

(Department of Biology and Agriculture, Faculty of Engineering, Universiti Putra Malaysia,
43400 Serdang, Selangor Darul Ehsan, Malaysia)

Abstract: The existing mechanized oil palm harvester is claimed to be unsuccessful due to its inefficiency to harvest Fresh Fruit Bunch (FFB). It takes a lot of time compared to the conventional harvesting method, using human power. Therefore a study was carried out using Denavit and Hartenberg (D-H) approach to automate the five Degrees of Freedom (DOF) harvester manipulator. The general objective was to reduce the number of workers required for harvesting as well as to provide comfortable ergonomic for the operator of oil palm harvester. The D-H's convention was used for selecting frames of reference in robotics application which has become the standard way of representing robots and modeling their motions. In this study, the forward kinematics and inverse kinematics were used to deduce joint angles variables while the conventional Jacobian was used for motion velocity computation. The formulated inverse equations were tested manually on the harvester with given locations to obtain deduced joint angles. The results were $\theta_1=129.64^\circ$, $\theta_3=180^\circ$, $\theta_4=90^\circ$, which were quite accurate. Thus, the kinematics analysis of harvester arm automation was done successfully.

Keywords: kinematics, Degrees of Freedom, harvesters, manipulators, denavit and hartenberg, Fresh Fruit Bunch

DOI: 10.3965/j.issn.1934-6344.2010.03.001-007

Citation: Helena Anusia James Jayaselan, Wan Ishak Wan Ismail. Kinematics analysis for five DOF Fresh Fruit Bunch harvester. *Int J Agric & Biol Eng*, 2010; 3(3): 1–7.

1 Introduction

Throughout the past decades many machines were invented for oil palm harvesting by Malaysian Palm Oil Board (MPOB) but none of them was made commercial due to its inefficiency. This was because the harvester operator faces difficulty in positioning the mechanical cutter to the bunch stalk during cutting process. The operator takes a lengthy time (7-15 min) just to adjust the position of the cutter and grabber to perform the harvesting process, compared to a worker who manages to harvest a tree in just three to five minutes using a chisel. Not only was the operation taking a long time, but also the operator experiences neck aches and body pain after harvesting operation on only one palm tree. Therefore, the ergonomic of the operator is also an issue here. A lot of time was wasted in locating the Fresh Fruit Bunch (FFB) and eventually decreasing the overall productivity.

On the average, a worker's daily harvest was around 80-100 bunches, however, the mechanical harvester was only able to harvest 30-50 bunches a day. Thus, not only the number of bunches harvested was lesser but the other ripened bunches that were not able to be harvested would develop into an over-ripened bunch that may affect the quality of the oil produced in terms of free fatty acids, which indirectly affects the productivity as well. Thus, this problem should be addressed in terms of time efficiency. This would include the hydraulic efficiency, mechanical efficiency as well as electrical efficiency of the harvester. Automation of the whole harvesting process also increases the time-based efficiency. The automated harvester should be able to view, locate and harvest the fresh fruit bunch within a short period of time. Installation of a camera vision system to the harvester machine assists and automates the cutting process, thus eventually overcome the problem. Nevertheless, agricultural tasks were not favored by human of future generation also calls for robotics research, especially for

tasks that were dangerous, repetitive, tedious and for tasks that required beyond human capabilities. The scope of the study is to use outdoor camera vision to capture FFB position, threshold and locate its position as well as automate the harvesting procedure for accurate cutting. The more specified objectives would be able to move the manipulator automatically using Denavit and Hartenberg approach.

2 Literature review

Jaques Denavit and Richard S. Hartenberg^[2] introduced a convention for selecting frames of reference in robotics application, where each homogeneous transformation was represented minimally as product of four basic transformations, based on the main geometric concept of common normal between two lines. The Denavit and Hartenberg (D-H) representation has become the standard way of representing robots and modeling their motions. The method begins with a systematic approach to assigning and labeling an orthonormal (x , y , z) coordinate system to each robot joint. It is then possible to relate one joint to the next and ultimately to assemble a complete representation of a robot's geometry. D-H convention was mainly implemented in robot manipulators which consist of an open kinematic chain in which each joint contains one DOF with either revolute or prismatic joint. The transformation was described by the following four parameters known as D-H parameters:

- a : length
- α : twist
- d : twist
- θ : angle

Bouketir^[1] has developed a vision based interface for a three DOF agricultural robot that involved the D-H approach. Experiments were carried out for the robot to grab the target which was a red fruit (FFB) with help of vision (CCD camera) and back to the home position. The D-H approach systematically describes arbitrary robot geometries and simplifies their analysis. For instance the investigation carried by Santos and Valero^[9], whether a single parametric kinematic model can represent all thumbs or different models needed for different thumbs, was done by converting anatomy-base description of

kinematic structure of thumb into standard robotics notation (D-H) for use in robotics based musculoskeletal models. Monte Carlo simulations were used as approach to yield statistical distributions for D-H parameters that emerge naturally from the statistical distribution of the anatomical data. In the effort to develop a mobile robot system for working in the double-hulled structure of a ship, D. Lee et al^[4] used D-H parameters to solve the kinematics of the 3P3R (six DOF manipulator). The RRX robot was designed to replace labor in U-shape welding that was carried in blocks which was hazardous. A case study was carried out by Santis and Siciliano^[8] based on a three link planar manipulator approaching an object at specified position where an approach to Inverse Kinematics for possibly moving control points on kinematic chain at robot manipulator was introduced.

Forward and backward kinematics analyses were both very important for the earlier determination of the robot's end (hand) position while the later enables calculations on the position of each joint variable of end (hand) desired location at a particular point and particular orientation. Matrices were used to represent frames, points, translations, rotations and transformations as well as other kinematic elements. As a representation of a point in space, three coordinates relative to a reference frame was presented by Saeed^[7] as:

$$P = a_x\hat{i} + b_y\hat{j} + c_z\hat{k} \quad (1)$$

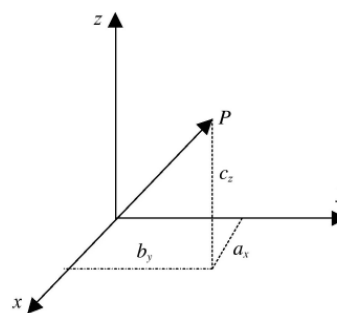

Figure 1 Representation of vector in space

If there was a fixed reference frame where the frame was not at its origin as in Figure 1, then location of the origin of the frame relative to the reference frame must also be expressed through its components relative to the reference frame. Thus, three vectors will express its directional unit vectors while a fourth vector is introduced to describe its location as shown below:

$$F = \begin{bmatrix} nx & ox & ax & Px \\ ny & oy & ay & Py \\ nz & oz & az & Pz \\ 0 & 0 & 0 & 1 \end{bmatrix} \quad (2)$$

A study on synthesis problem of repeatable Jacobian Inverse Kinematics algorithm for robotic manipulator was carried out by Janiak and Tchon^[3] by definition of extended Jacobian inverse as Jacobian pseudo-inverse where the extended Jacobian has better quadratic convergence (non repeatable), contrary to the usual Jacobian algorithm. The Jacobian matrix was a linear transformation matrix that maps an n-dimensional velocity vector q into an m-dimensional velocity vector x , where the vector x was a nonlinear function of q that Jacobian matrix was also a function of q and was configuration dependant^[5]. They were usually defined by conventional Jacobian and screw-based Jacobian;

Conventional Jacobian \rightarrow Screw-based Jacobian

$$\dot{x} = \begin{bmatrix} v_n \\ \omega_n \end{bmatrix} \quad \dot{x} = \begin{bmatrix} \omega_n \\ v_o \end{bmatrix} \quad (3)$$

In the conventional Jacobian, the end effector velocity state was expressed in terms of linear velocity of the origin of the end effector coordinate frame, v_n and the angular velocity of the end effector ω_n while the screw-based Jacobian was defined in terms of angular velocity of the end effector, ω_n and linear velocity of reference point v_o in the end effector coincide with the reference frame. In general, the Jacobian matrix was an $m \times n$ matrix, where n denotes the number of actuated joint variables and m denotes the DOF of the end effector space. However, for a manipulator with less than six DOF, the end effector velocity state may just contain the linear velocity vector or the angular velocity vector or combination of some linear and angular velocity vector components.

3 Methodology

Figure 2 shows an oil palm harvester developed under the collaboration of resources of the Malaysian Palm Oil Board (MPOB), Universiti Putra Malaysia (UPM) and Universiti Kebangsaan Malaysia (UKM). Figure 3 shows the schematic diagram of the harvester manipulator used to cut and harvest the oil palm FFB. The aim of the project was to model the manipulator arm

using D-H representation.



Figure 2 FFB harvester (currently located at MPOB, Bangi Lama)

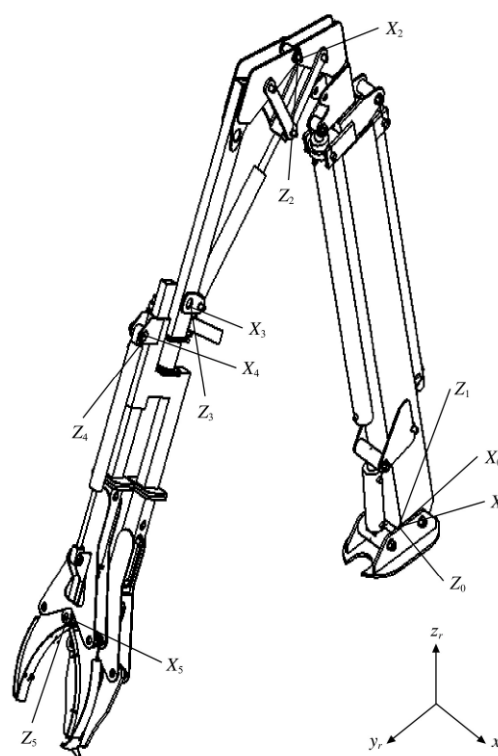

Figure 3 Denavit and Hartenberg notation of harvester manipulator

4 Forward kinematics

To model the harvester to D-H representation, the first step was the assignment of a local reference frame for each and every joint. Thus, for each joint, x-axis and z-axis were assigned but y-axis was not assigned because the D-H representation does not use the y-axis. The following was the procedure for assigning a local reference frame to each joint:

- All joints were represented by a z-axis.

If the joint was revolute, the z-axis was in direction of

rotation and followed by right hand rule for rotations. The rotation about z -axis (θ) was joint variable.

If the joint was prismatic, the z -axis for the joint was along the direction of linear movement. The length of the link along z -axis (d) was the joint variable

The index number for joint n is z_{n-1} .

- The z -axes were skew lines and the line mutually perpendicular to any two skew lines was the common normal line, with the shortest distance between the two skew lines and was represented by a_n and the direction of common normal was x_n .

- If two joint z -axes are parallel, the line that was colinear with common normal of previous joint was chosen to simplify the model.

- If the z -axes of two successive joints are intersecting, there was no common normal. Thus, x -axis was assigned along a line perpendicular to the plane formed by the two axes.

The list of definition of D-H parameters according to Rachid^[6]:

- θ was called the link angle, representing a rotation about z -axis,

- d was called link offset, representing the distance along the z -axis between two successive common normals,

- a was called the link length, representing length of each common normal, which was the shortest distance between two consecutive joints of z -axes

- α was called link twist, representing the angle of x -axis between two successive z -axes.

Starting with the reference frame, transformation was done by the base of robot, followed by the first joint and the second joint then the third, fourth and fifth joint until to the end effector. Beginning at joint 1 where z_0 represents the first joint which was a revolute joint where x_0 was parallel to reference frame x_r -axes, while z_0 -axis was parallel to z_r -axis for convenience. This was also because of D-H modeling rules that the z_0 -axis must lie on the first joint axis^[6]. The movement of θ_1 occurs around z_0-x_0 axes, but both the axes were not involved in the motion. Then z_1 was assigned to joint 2 with motion around z_1 -axis while x_1 will be normal to z_0 and z_1 since the two axes are intersecting. Sliding variable d_2

quantifies the translation along axis z_1 for the prismatic joint. Due to that, the z_2 -axis was at perpendicular to z_1 -axis which makes x_2 axis to be in direction of common normal to z_2 and z_1 axes. Movement of an angle of θ_3 was around z_2-x_2 axes.

For joint 3, the x_3 -axis was in direction of common normal to z_3 and z_2 as the z_2 -axis was perpendicular to z_3 -axis. A movement of θ_4 occurs around z_4-x_4 axes. The translation along z_5 -axis for the second prismatic joint was represented by variable d_5 . Meanwhile z_4 and z_5 axes were as shown in Figure 3 because they were in a parallel colinear formation. The z_5 -axis represents motions of the end effector which was a grabber. Although end effectors were usually not included in motion equations, it is necessary to allow transformation out of frame z_5-x_5 to determine the total transformation equation later. The cutter was not included in the automation because it was done manually at this stage.

To simplify the kinematic equations, most of the D-H parameters were zeroed and this was usually done by having the position of robot in its home position. The home position refers to robot configuration where almost all joint variables assume a null value. In this position, all the x -axes of all joint frames were typically aligned as shown in the Figure 3 below.

To facilitate with the calculations, a D-H table of joint and link parameters was constructed based on Saeed^[7] and Rachid^[6] as shown in Table 1. The harvester has five DOF where the first joint 1 was between link 0 (the fixed base) and link 1 (z_0-z_1), joint 2 (z_1-z_2) between link 1 and 2, and so on.

Table 1 D-H parameters representation of harvester

Joint	θ (Link angle)	D (Link Offset)	a (Link Joint)	α (Link Twist)
1(z_0-z_1)	θ_1	0	0	90
2(z_1-z_2)	0	d_2	a_1	90
3(z_2-z_3)	θ_3	0	a_2	90
4(z_3-z_4)	θ_4	0	0	0
5(z_4-z_5)	0	d_5	0	0

The transformation between two successive joints was written by substituting the D-H parameters from Table 1 into the A matrix. The θ and d were the joint variables for revolute joints and prismatic joints respectively with C_1 as $\cos\theta_1$ and S_1 as $\sin\theta_1$ designation. For instance, A_1

matrix was between frame 0 and 1, as well as A_2 through A_5 for the other joints and was as follows:

$${}^R T_H = A_1 A_2 A_3 A_4 A_5 \quad (4)$$

$$\text{where, } A_1 = \begin{bmatrix} C_1 & 0 & S_1 & 0 \\ S_1 & 0 & -C_1 & 0 \\ 0 & 1 & 0 & 0 \\ 0 & 0 & 0 & 1 \end{bmatrix}, \quad A_2 = \begin{bmatrix} 1 & 0 & 0 & a_1 \\ 0 & 1 & 0 & 0 \\ 0 & 0 & 0 & d_1 \\ 0 & 0 & 0 & 1 \end{bmatrix},$$

$$A_3 = \begin{bmatrix} C_3 & 0 & S_3 & C_3 a_2 \\ S_3 & 1 & -C_3 & S_3 a_2 \\ 0 & 1 & 0 & 0 \\ 0 & 0 & 0 & 1 \end{bmatrix}, \quad A_4 = \begin{bmatrix} C_4 & -S_4 & 0 & 0 \\ S_4 & C_4 & 0 & 0 \\ 0 & 0 & 1 & 0 \\ 0 & 0 & 0 & 1 \end{bmatrix},$$

$$A_5 = \begin{bmatrix} 1 & 0 & 0 & 0 \\ 0 & 1 & 0 & 0 \\ 0 & 0 & 1 & d_5 \\ 0 & 0 & 0 & 1 \end{bmatrix}$$

Kinematics analysis was the calculation of the position and orientation of robot hand, where position of robot can be calculated instantly if all joint variables were known where D-H parameters were used. However, to place the robot arm in a desired location, the amount of each joint movement must be known and this was called the inverse kinematic analysis. In reality, the inverse kinematics was important to place the arm at desired position and can be derived from forward kinematic equations set.

The forward kinematics was developed using D-H notations on the harvester where the results were based on the basic notation from Equation (2) that represents the product of seven matrices representing the transformation of the successive joints:

$${}^R T_H = A_1 A_2 A_3 A_4 A_5$$

Thus the result is;

$${}^R T_H = (A_1 A_2 A_3 A_4 A_5) = \begin{bmatrix} n_x & o_x & a_x & P_x \\ n_y & o_y & a_y & P_y \\ n_z & o_z & a_z & P_z \\ 0 & 0 & 0 & 1 \end{bmatrix} \quad (5)$$

Where:

$$n_x = C_1 C_3 C_4 + S_1 S_4$$

$$n_y = S_1 C_3 C_4 - C_1 S_4$$

$$n_z = S_3 C_4$$

$$o_x = -C_1 C_3 S_4 + S_1 C_4$$

$$o_y = -S_1 C_3 S_4 - C_1 C_4$$

$$o_z = -S_3 S_4$$

$$a_x = C_1 S_3$$

$$a_y = S_1 S_3$$

$$a_z = -C_3$$

$$P_x = C_1 [S_3 d_5 + C_3 a_2 + a_1] + S_1 d_2$$

$$P_y = S_1 [S_3 d_5 + C_3 a_2 + a_1] - C_1 d_2$$

$$P_z = -C_3 d_5 + S_3 a_2$$

Hence first three elements of last column, (P_x , P_y , P_z) represent the coordinates of (x_e , y_e , z_e) of the end effector with respect to the base coordinate system (x_0 , y_0 , z_0). This is very important for locating the home position of the oil palm harvester.

5 Inverse kinematics

As for the inverse kinematics analysis, the same Equation (5) developed for forward kinematics was used to begin the calculation to determine the value of each joint in order to place the end effector at the desired position and orientation as in Figure 4. Since Equation (5) has many coupled angles, the ${}^R T_H$ matrix will be premultiplied with individual A_n^{-1} matrices to decouple the angles, so;

$$A_n^{-1} \times \begin{bmatrix} n_x & o_x & a_x & P_x \\ n_y & o_y & a_y & P_y \\ n_z & o_z & a_z & P_z \\ 0 & 0 & 0 & 1 \end{bmatrix} = A_2 A_3 A_4 A_5$$

$$\begin{bmatrix} C_1 & S_1 & 0 & 0 \\ 0 & 0 & 1 & 0 \\ S_1 & -C_1 & 0 & 0 \\ 0 & 0 & 0 & 1 \end{bmatrix} \times \begin{bmatrix} n_x & o_x & a_x & P_x \\ n_y & o_y & a_y & P_y \\ n_z & o_z & a_z & P_z \\ 0 & 0 & 0 & 1 \end{bmatrix} = A_2 A_3 A_4 A_5$$

$$A_2 A_3 A_4 A_5 =$$

$$\begin{bmatrix} C_1 n_x + S_1 n_y & C_1 o_x + S_1 o_y & C_1 a_x + S_1 a_y & C_1 P_x + S_1 P_y \\ n_z & o_z & a_z & P_z \\ S_1 n_x + S_1 n_y & S_1 o_x + C_1 o_y & S_1 a_x + C_1 a_y & S_1 P_x - C_1 P_y \\ 0 & 0 & 0 & 1 \end{bmatrix} = \begin{bmatrix} C_3 C_4 & -C_3 S_4 & S_3 & S_3 d_5 + C_3 a_2 + a_1 \\ S_3 C_4 & S_3 S_4 & C_3 & -C_3 d_5 + S_3 a_2 \\ S_4 & C_4 & 0 & d_2 \\ 0 & 0 & 0 & 1 \end{bmatrix} \quad (6)$$

Since,

$$S_1 a_x - C_1 a_y = 0$$

$$S_1 a_x = C_1 a_y$$

$$S_1 / C_1 = a_y / a_x$$

$$\theta_1 = \tan^{-1} [a_y / a_x] \quad (7)$$

Next, from Equation (5),

$$\begin{aligned} a_z &= -C_3 \\ C_3 &= -a_z \\ \theta_3 &= \cos^{-1}(-a_z) \end{aligned} \quad (8)$$

And finally, from Equation (6) as well,

$$\begin{aligned} C_4 &= S1ox - C1oy \\ \theta_4 &= \cos^{-1}(S1ox - C1oy) \end{aligned} \quad (9)$$

Once angle θ_1 , θ_3 , and θ_4 were known, the manipulator was able to move towards its desired location with the computation of cylinder extraction. As an experiment, the angles θ_1 , θ_3 , and θ_4 are found with the given location of $[2 \ 3 \ 9]^T$ as shown below:

Known variables:

$$\begin{aligned} a_1 &= 0.3 \text{ m} & d_2 &= 4.66 \text{ m} \\ a_2 &= 0.238 \text{ m} & d_5 &= 1.202 \text{ m} \end{aligned}$$

By using Equation (6) the matrix computation is done and the following is based on Equation (7),

$$\begin{aligned} \theta_1 &= \tan^{-1}[a_y / a_x] \\ \theta_1 &= 0^\circ \end{aligned}$$

Thus, $C1=1$ and $S1=0$

Next, using Equation (8),

$$\begin{aligned} \theta_3 &= \cos^{-1}(-a_z) \\ \theta_3 &= 180^\circ \end{aligned}$$

Thus, $C_3=-1$ and $S_3=0$

Then the following is from Equation (9),

$$\begin{aligned} \theta_4 &= \cos^{-1}(S1ox - C1oy) \\ \theta_4 &= 180^\circ \end{aligned}$$

Once the angle θ_1 , θ_3 and θ_4 were found as 0° , 180° and 180° respectively, they were used to move the harvester rotational joints to the desired position, which was the location of the particular FFB where the grabber was in a position to grab.

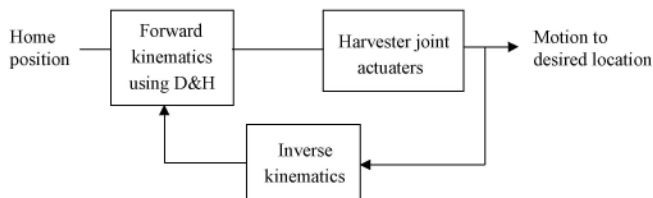

Figure 4 Block diagram of kinematics analysis

6 Jacobian calculation

Based on the conventional Jacobian, the origin of end effector frame was chosen as the reference point to

describe the velocity state of the end effector which can be expressed in terms of joint rates as follows:

$$V_n = \sum_{i=1}^n [\theta_i (z_i - 1x_i - 1P_n^*) + z_i - 1d_i] \quad (10)$$

$$\omega_n = \sum_{i=1}^n \theta_i (z_i - 1) \quad (11)$$

Where: θ_i and d_i were rate of rotation about the translation along the i th joint axis, z_{i-1} was a unit vector along the i th joint axis, and ${}^{i-1}P_n^*$ was a vector defined from the origin of the $(i-1)$ th link frame, to the origin of the end effector frame^[5]. All vectors are expressed in fixed coordinate frame which in matrix was:

$$x' = \begin{bmatrix} v_n \\ \omega_n \end{bmatrix} = Jq \quad (12)$$

where;

$$J = [J_1, J_2, J_3, \dots, J_n],$$

$$J_i = \begin{bmatrix} z_i - 1x_i - 1P_n^* \\ z_i - 1 \end{bmatrix} \text{ for revolute joint,}$$

$$J_i = \begin{bmatrix} z_i - 1 \\ 0 \end{bmatrix} \text{ for prismatic joint.}$$

And the position vector ${}^0P_5^*$ were derived by applying the following equation;

$$\begin{aligned} {}^{i-1}P_n^* &= {}^0R_{i-1} {}^{i-1}r_i + {}^iP_n^* \\ {}^0P_5^* &= \begin{bmatrix} C_1[S_4d_2 + C_4a_2 + a_1] + S_1d_1 \\ S_1[S_4d_2 + C_4a_2 + a_1] - C_1d_1 \\ -C_4d_2 + S_4a_2 \end{bmatrix} \end{aligned} \quad (13)$$

The Jacobian matrix was derived by applying Equation (13) column by column:

$$\begin{bmatrix} v6x \\ v6y \\ v6z \\ \omega x \\ \omega y \\ \omega z \end{bmatrix} = I \begin{bmatrix} \theta_1 \\ \theta_2 \\ \theta_3 \\ \theta_4 \\ \theta_5 \\ \theta_6 \end{bmatrix}$$

And thus, the Jacobian matrix is given by:

$$J = \begin{bmatrix} -S_1[S_4d_2 + C_4a_2 + a_1] + C_1d_1 & S_1 & C_1C_4d_2 - S_4a_2C_1 & 0 & C_1S_4 & 0 \\ C_1[S_4d_2 + C_4a_2 + a_1] + S_1d_1 & -C_1 & S_1C_4d_2 - S_4a_2 & 0 & S_1S_4 & 0 \\ 0 & 0 & S_4d_2 + C_4a_2 & 0 & -C_4 & 0 \\ 0 & S_1 & 0 & C_1S_3 & 0 & 0 \\ 0 & -C_1 & 0 & S_1S_3 & 0 & 0 \\ 0 & 0 & 0 & -C_3 & 0 & 0 \end{bmatrix} \quad (14)$$

Based on the experimental values found earlier, the corresponding values were replaced yielding the

following Jacobian matrix:

$$J = \begin{bmatrix} 1.816 & 0.770 & -0.152 & 0 & -0.638 & 0 \\ 4.546_1 & 0.638 & -0.238 & 0 & 0.770 & 0 \\ 0 & 0 & 1.202 & 0 & 0 & 0 \\ 0 & 0.770 & 0 & 0 & 0 & 0 \\ 0 & 0.638 & 0 & 0 & 0 & 0 \\ 0 & 0 & 0 & 1 & 0 & 0 \end{bmatrix} \quad (15)$$

With this, the mathematical relationship between the joint motion and the end effector motion resulted in Equation (15) leads to the development of the manipulator Jacobian. The six rows in the matrix denote the task dimension while the six columns show the number of joints existing in the harvester. As a known fact, this has only five DOF, thus the final column is empty or valueless. This result serves as useful tool for harvester manipulator analysis and to control the end-effector angular and linear velocity. The joint motion velocity for all five joints was found easily and thus can be manipulated along its trajectory according to desired harvesting rate.

7 Conclusions

As a conclusion, the oil palm harvester was found able to move to the desired position, given its location through vision based feedback system by using the forward and inverse kinematics equation that has been developed specially for this five DOF oil palm harvester. Since the end effector was not automated, the operator had to actuate it manually. Nevertheless, the operator will be able to have more relaxed operation and will be able to harvest the fresh fruit bunch much faster. Future

studies on accuracy and end effector automation are encouraged on this oil palm harvester.

[References]

- [1] Bouketir Omrane. Design and development of a vision system interface for three degree of freedom agricultural robot. MSc Thesis. Malaysia: Universiti of Putra, 1999.
- [2] Denavit J, Hartenberg R S. A kinematic notation for lower-pair mechanisms based on matrices. *Journal of Applied Mechanics*, 1995; (23): 215–221.
- [3] Janiak M, Tchou K. Extended jacobian inverse kinematics and approximation of distribution. *Advances in Robot Kinematics: Analysis and Design*, 2008; 138–146.
- [4] Lee D, Lee S, Ku N, Lim C, Lee K Y, Kim T W, et al. Development of a mobile robotic system for working in the double hulled structure of ship. *Robotics and computer-integrated manufacturing*, 2010; 26(1):13–23.
- [5] Lung-Wen Tsai. *Robot analysis*, Wiley Interscience Publication of John Wiley & Sons, Inc. 1999.
- [6] Rachid Mansour. *Robot modeling and kinematics*, Da Vinci Engineering Press, Boston Massachusetts. 2006.
- [7] Saeed B Niku. *Introduction to robotics: Analysis Systems, Applications*, Prentice Hall, Upper Saddle River, NJ 07458. 2001.
- [8] Santis A D, Siciliano B. Inverse kinematics of robot manipulator with multiple moving control points. In: 11th International Symposium on Advances in Robot Kinematics Batz-Sur-Mer, Lenarcic-Wenger, (Eds) *Advances in Robot Kinematics: Analysis and Design*, Springer, 2008: 429–438.
- [9] Santos V J, Valero C F J. Anatomical variability naturally leads to multimodal distributions of denavit-hartenberg parameters for the human thumb. *IEEE Transactions On Biomedical Engineering*, 2003; 17–21.