

Types of fasteners: Pins and keys

Instructional Objectives

At the end of this lesson, the students should have the knowledge of

- Fasteners and their types: permanent and detachable fasteners.
- Different types of pin joints.
- Different types of keys and their applications.

4.1.1 Introduction: Types of fasteners

A machine or a structure is made of a large number of parts and they need be joined suitably for the machine to operate satisfactorily. Parts are joined by fasteners and they are conveniently classified as permanent or detachable fasteners. They are often sub- divided under the main headings as follows:

Permanent fasteners: Riveted joints

Welded joints

Detachable joints: Threaded fasteners – screws, bolts and nuts, studs.

Cotter joints

Knuckle joints

Keys and Pin joints

Starting with the simple pin and key joints all the main fasteners will be discussed here.

4.1.2 Pin Joints

These are primarily used to prevent sliding of one part on the other, such as, to secure wheels, gears, pulleys, levers etc. on shafts. Pins and keys are primarily used to transmit torque and to prevent axial motion. In engineering practice the following types of pins are generally used.

(a) Round pins (b) Taper pins (c) Dowel pins (d) Split pins

Round and taper pins are simple cylindrical pins with or without a taper and they offer effective means of fastening pulleys, gears or levers to a shaft. It may be fitted such that half the pin lies in the hub and the other half in the shaft as shown in **figure-4.1.2.1 (b)**. The pin may be driven through the hub and the shaft as in **figure- 4.1.2.1 (c)** or as in **figure- 4.1.2.1 (d)**. These joints give positive grip and the pins are subjected to a shear load. For example, for the shaft in the assembly shown in **figure- 4.1.2.1 (c)**, the pin is under double shear and we have

$$\tau \left(2 \frac{\pi}{4} d^2 \right) \cdot \frac{D_1}{2} = T$$

where d is the diameter of the pin at hub-shaft interface, τ is the yield strength in shear of the pin material and T is the torque transmitted.

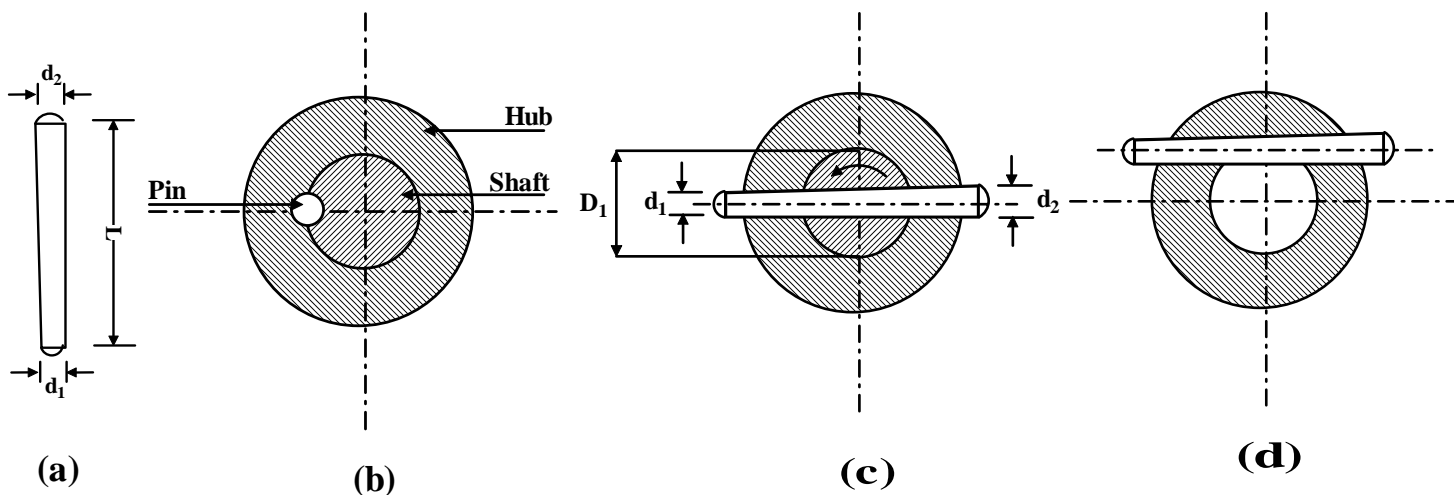

4.1.2.1F- Different types of pin joints

A taper pin is preferred over the straight cylindrical pins because they can be driven easily and it is easy to ream a taper hole.

Dowel pins

These are used to keep two machine parts in proper alignment. **Figure- 4.1.2.2** demonstrates the use of dowel pins. Small cylindrical pins are normally used for this purpose.

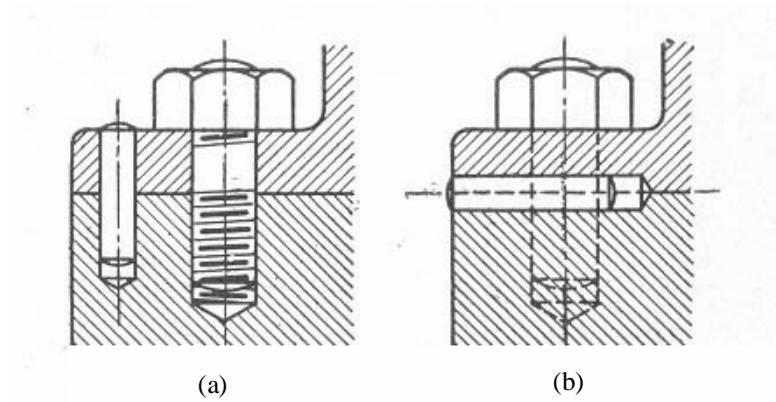

4.1.2.2F- Some uses of Dowel pins (Ref.[6]).

Split pins

These are sometimes called cotter pins also and they are made of annealed iron or brass wire. They are generally of semi-circular cross section and are used to prevent nuts from loosening as shown in **figure- 4.1.2.3**. These are extensively used in automobile industry.

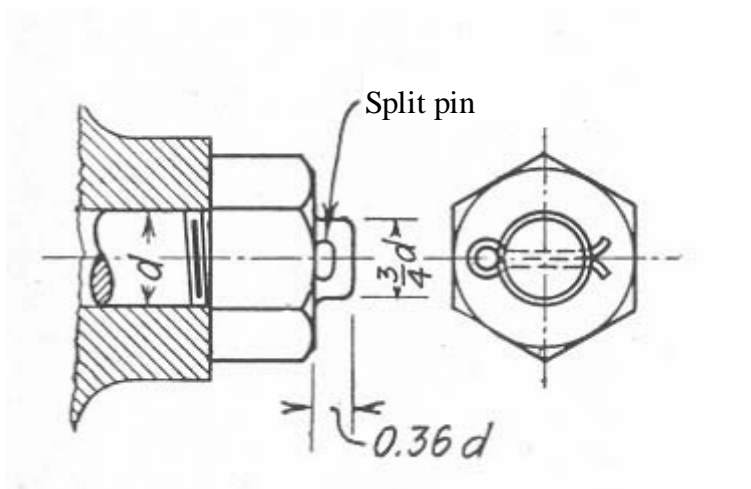

4.1.2.3F- Typical use of a split pin (Ref.[6]).

4.1.3 Keys

Steel keys are widely used in securing machine parts such as gears and pulleys. There is a large variety of machine keys and they may be classified under four broad headings:

Sunk keys, flat keys, saddle keys and pins or round keys

Sunk keys may be further classified into the following categories:

- (a) Rectangular sunk keys
- (b) Gib head sunk keys
- (c) Feather keys
- (d) Woodruff keys

Rectangular sunk keys are shown in **figure- 4.1.3.1**. They are the simplest form of machine keys and may be either straight or slightly tapered on one side. The parallel side is usually fitted into the shaft.

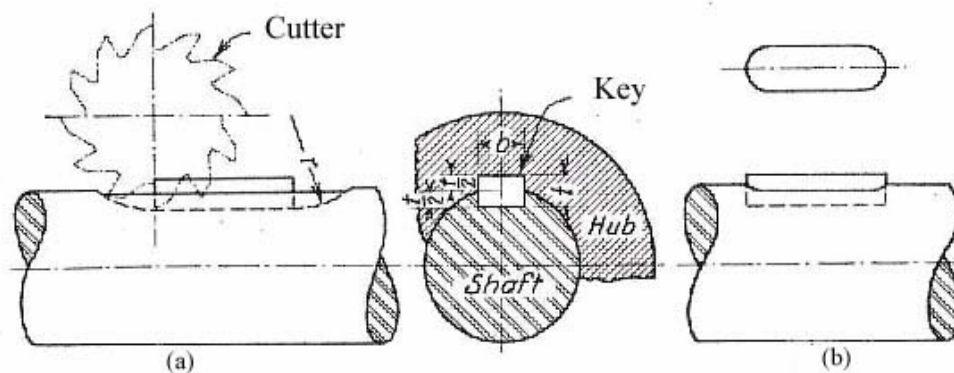

4.1.3.1F- Rectangular sunk keys (Ref.[6]).

The slots are milled as shown in **figure- 4.1.3.1(a)**. While transmitting torque a rectangular sunk key is subjected to both shear and crushing or bearing stresses.

Considering shear we may write $\tau \cdot b \cdot l \cdot \frac{D}{2} = T$ where τ is the yield shear stress of the key material, D the shaft diameter and T is torque transmitted. Considering

bearing stress we may write $\sigma_{br} \cdot \frac{t \cdot l}{2} \cdot \frac{D}{2} = T$

where σ_{br} is the bearing stress developed in the key. Based on these two criteria key dimensions may be optimized and compared with the standard key dimensions available in design hand books.

The **gib head keys** are ordinary sunk keys tapered on top with a raised head on one side so that its removal is easy. This is shown in **figure- 4.1.3.2**

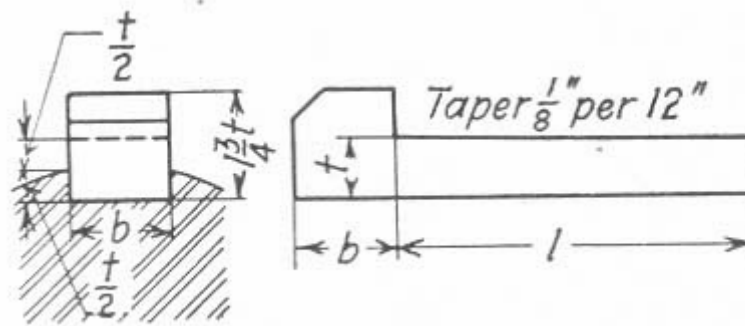

4.1.3.2F- Gib head key (Ref.[6]).

Some **feather key** arrangements are shown in **figure- 4.1.3.3**. A feather key is used when one component slides over another. The key may be fastened either to the hub or the shaft and the keyway usually has a sliding fit.

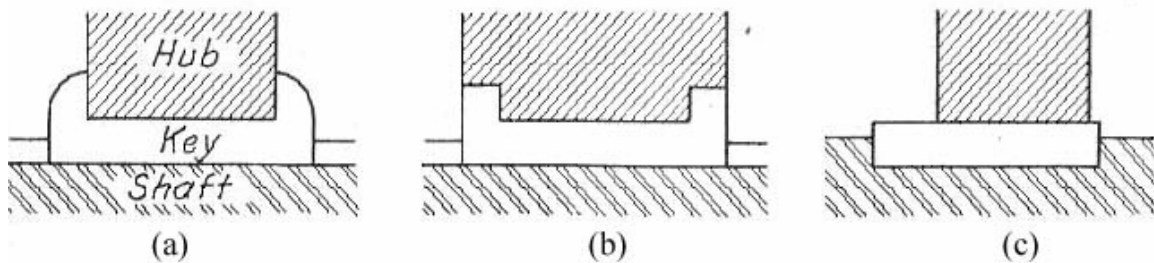

4.1.3.3F- Some feather key arrangements (Ref.[6]).

A **woodruff key** is a form of sunk key where the key shape is that of a truncated disc, as shown in **figure- 4.1.3.4**. It is usually used for shafts less than about 60 mm diameter and the keyway is cut in the shaft using a milling cutter, as shown in the **figure- 4.1.3.4**. It is widely used in machine tools and automobiles due to the extra advantage derived from the extra depth.

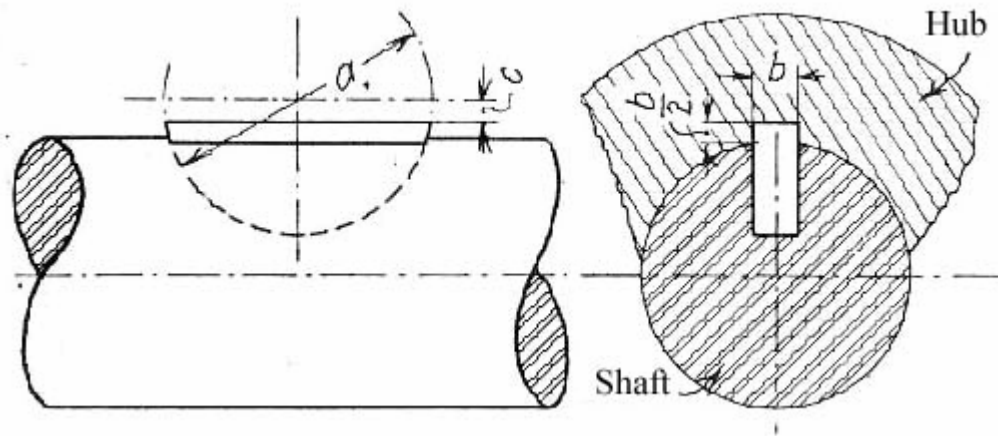

4.1.3.4F- Woodruff key (Ref.[6]).

Lewis keys, shown in **figure- 4.1.3.5**, are expensive but offer excellent service. They may be used as a single or double key. When they are used as a single key the positioning depends on the direction of rotation of the shaft. For heavy load two keys can be used as shown in **figure- 4.1.3.5 (b)**.

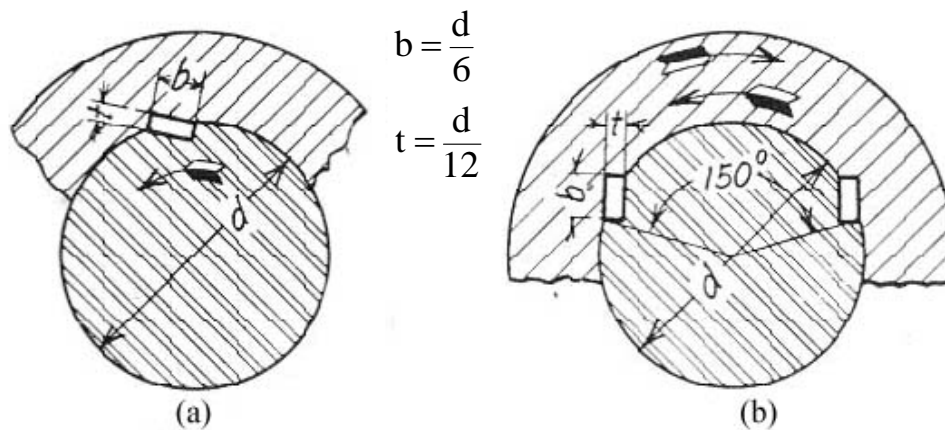

4.1.3.5F- Lewis keys (Ref.[6]).

A **flat key**, as shown in **figure- 4.1.3.6** is used for light load because they depend entirely on friction for the grip. The sides of these keys are parallel but the top is

slightly tapered for a tight fit. These keys have about half the thickness of sunk keys.

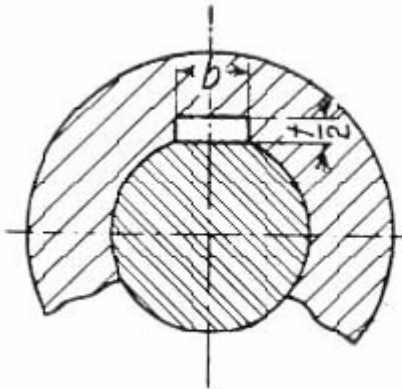

4.1.3.6F- Flat key (Ref.[6]).

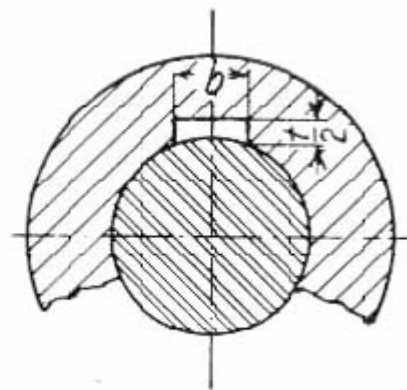

4.1.3.7F- Saddle key (Ref.[6]).

A **saddle key**, shown in **figure- 4.1.3.7**, is very similar to a flat key except that the bottom side is concave to fit the shaft surface. These keys also have friction grip and therefore cannot be used for heavy loads. A simple pin can be used as a key to transmit large torques. Very little stress concentration occurs in the shaft in these cases. This is shown in **figure- 4.1.2.1 (b)**.

4.1.4 Problems with Answers

Q.1: Two 30 mm diameter shafts are connected by pins in an arrangement shown in **figure-4.1.4.1**. Find the pin diameter if the allowable shear stress of the pins is 100 MPa and the shaft transmits 5 kW at 150 rpm.

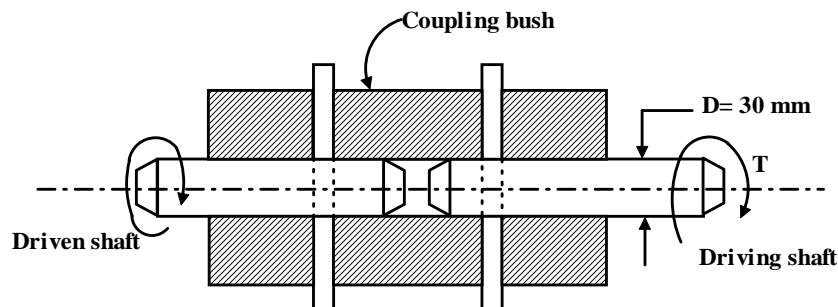

4.1.4.1F

A.1:

The torque transmitted $T = \text{Power} \left(\frac{2\pi N}{60} \right)$. Substituting power = 5×10^3

Watts and $N = 150$ rpm we have $T = 318.3$ Nm. The torque is transmitted from the driving shaft to the coupling bush via a pin. The torque path is then reversed and it is transmitted from the coupling bush to the driven shaft via another pin. Therefore both the pins transmit a torque of 318.3

Nm under double shear. We may then write $T = 2 \cdot \frac{\pi}{4} \cdot d^2 \cdot \tau_y \cdot \frac{D}{2}$. Substituting

$D = 0.03$ m, $\tau_y = 100$ MPa and $T = 318.3$ MPa we have $d = 11.6$ mm ≈ 12 mm.

Q.2: A heat treated steel shaft of tensile yield strength of 350 MPa has a diameter of 50 mm. The shaft rotates at 1000 rpm and transmits 100 kW through a gear. Select an appropriate key for the gear.

A.2:

Consider a rectangular key of width w , thickness t and length L as shown in **figure- 4.1.4.1**. The key may fail (a) in shear or (b) in crushing.

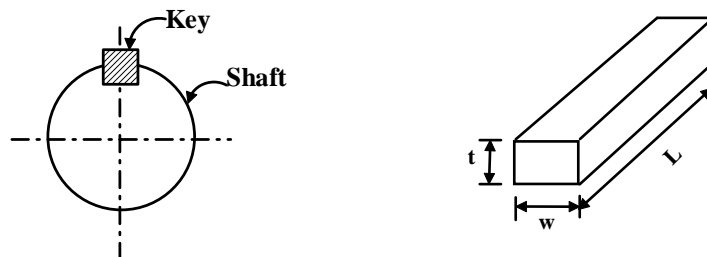

4.1.4.1F

Shear failure: The failure criterion is $T = \tau_y \cdot w \cdot L \cdot \frac{d}{2}$

(1)

where torque transmitted is $T = \text{Power} / \left(\frac{2\pi N}{60} \right)$

(2)

N being in rpm, w, L and d are the width, length and diameter of the shaft respectively and τ_y is the yield stress in shear of the key material. Taking τ_y to be half of the tensile yield stress and substituting the values in equations (1) and (2) we have $wL = 2.19 \times 10^{-4} \text{ m}^2$.

Crushing failure: $T = \sigma_c \cdot \frac{t \cdot L}{2} \cdot \frac{d}{2}$

(3)

Taking σ_c to be the same as σ_y and substituting values in equation (3) we have

$tL = 2.19 \times 10^{-4} \text{ m}^2$. Some standard key dimensions are reproduced in

table- 4.1.4.1:

Shaft Diameter (mm)	30-38	38-44	44-50	50-58	58-65	65-75	75-85
Key width, w (mm)	10	12	14	16	18	20	22
Key depth, t (mm)	8	9	9	10	11	12	14
Key length, L (mm)	22-110	28-140	36-160	45-180	50-200	56-220	63-250

4.1.4.1T

Based on the standard we may choose $w=16 \text{ mm}$. This gives $L = 13.6 \text{ mm}$. We may then choose the safe key dimensions as

$w = 16 \text{ mm}$ $L = 45 \text{ mm}$ $t = 10 \text{ mm}$.

4.1.5 Summary of this Lesson

In this lesson firstly the types detachable of fasteners are discussed. Then types and applications of pin and key joints are discussed with suitable illustrations. A brief overview of key design is also included.

Source:

http://nptel.ac.in/courses/Webcourse-contents/IIT%20Kharagpur/Machine%20design1/pdf/Module-4_lesson-1.pdf