

Module 7

Electrical Machine Drives

Lesson 32

Step Motors: Principles, Construction and Drives

Instructional Objectives

At the end of this lesson, the student should be able to

- Explain how a step motor is different from a conventional motor.
- Identify the major constructional difference between a permanent magnet and variable reluctance type motor.
- Distinguish between the terms *full stepping* and *half stepping*.
- Develop the switching sequence for a given step motor according to given requirements.
- Calculate the step angle.
- Explain what is meant by static position error.
- Name two different modes of operation for continuous rotation.
- Explain with schematic diagrams, open loop and closed loop control schemes used for step motors.

Introduction

Step motors (often referred as stepper motors) are different from all other types of electrical drives in the sense that they operate on discrete control pulses received and rotate in discrete steps. On the other hand ordinary electrical a.c and d.c drives are analog in nature and rotate continuously depending on magnitude and polarity of the control signal received. The discrete nature of operation of a step motor makes it suitable for directly interfacing with a computer and direct computer control. These motors are widely employed in industrial control, specifically for CNC machines, where open loop control in discrete steps are acceptable. These motors can also be adapted for continuous rotation. In this lesson we would discuss about the construction and principle of operations of different type of step motors and elaborate on the drive schemes used.

Construction

Step motors are normally of two types: (a) permanent magnet and (b) variable reluctance type. In a step motor the excitation voltage to the coils is d.c. and the number of phases indicates the number of windings. In both the two cases the excitation windings are in the stator. In a permanent magnet type step motor the rotor is a permanent magnet with a number of poles. On the other hand the rotor of a variable reluctance type motor is of a cylindrical structure with a number of projected teeth.

Permanent magnet step motor

The principle of step motor can be understood from the basic schematic arrangement of a small permanent magnet step motor is shown in Fig.1. This type of motor is called a two-phase two-pole permanent magnet step motor; the number of windings being two (phase 1 and phase 2) each split into two identical halves; the rotor is a permanent magnet with two poles. So winding A is split into two halves A_1 and A_2 . They are excited by constant d.c. voltage V and the direction of current through A_1 and A_2 can be set by switching of four switches Q_1 , Q_2 , Q_3 and

Q_4 as shown in Fig.2(a). For example, if Q_1 and Q_2 are closed, the current flows from A_1 to A_2 , while closing of the switches Q_3 and Q_4 sets the direction of current from A_2 to A_1 . Similar is the case for the halves B_1 and B_2 where four switches Q_5 - Q_8 are used to control the direction of current as shown in Fig. 2(b). The directions of the currents and the corresponding polarities of the induced magnets are shown in Fig. 1.

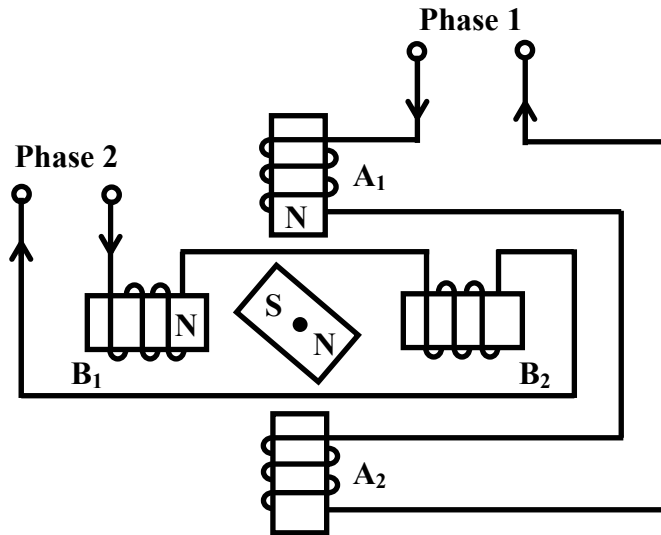

Fig. 1 Schematic diagram of a two-phase two-pole permanent magnet stepper motor.

Switching Sequence

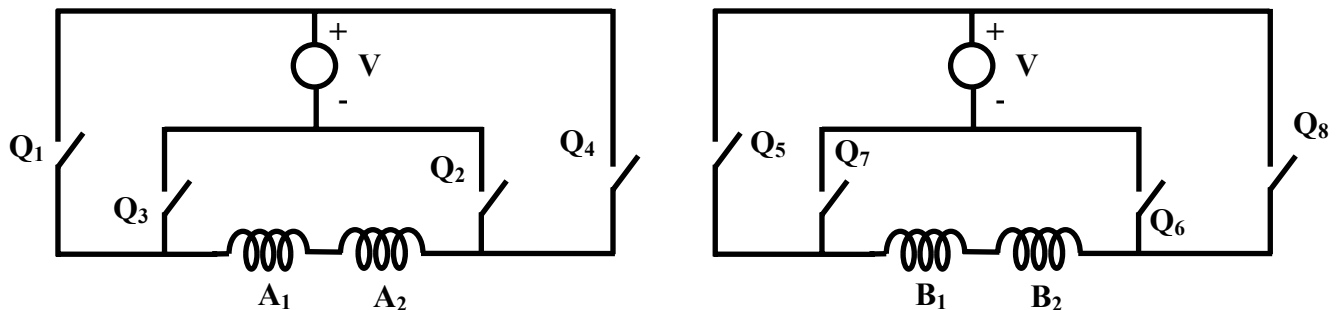

Fig. 2 Switching sequence for Fig. 1.

Now consider Fig. 3. Let Winding A be energised and the induced magnetic poles are as shown in Fig. 3(a) (we will denote the switching condition as $S_1=1$). The other winding B is not energised. As a result the moving permanent magnet will align itself along the axis of the stator poles as shown in Fig. 3(a). In the next step, both the windings A and B are excited simultaneously, and the polarities of the stator poles are as shown in Fig. 3(b). We shall denote $S_2=1$, for this switching arrangement for winding B. The rotor magnet will now rotate by an angle of 45° and align itself with the resultant magnetic field produced. In the next step, if we now make $S_1=0$ (thereby de-energising winding A), the rotor will rotate further clockwise by 45° and align itself along winding B, as shown in Fig. 3(c). In this way if we keep on changing the switching sequence, the rotor will keep on rotating by 45° in each step in the clockwise direction. The switching sequences for the switches Q_1 to Q_8 for first four steps are tabulated in Table 1.

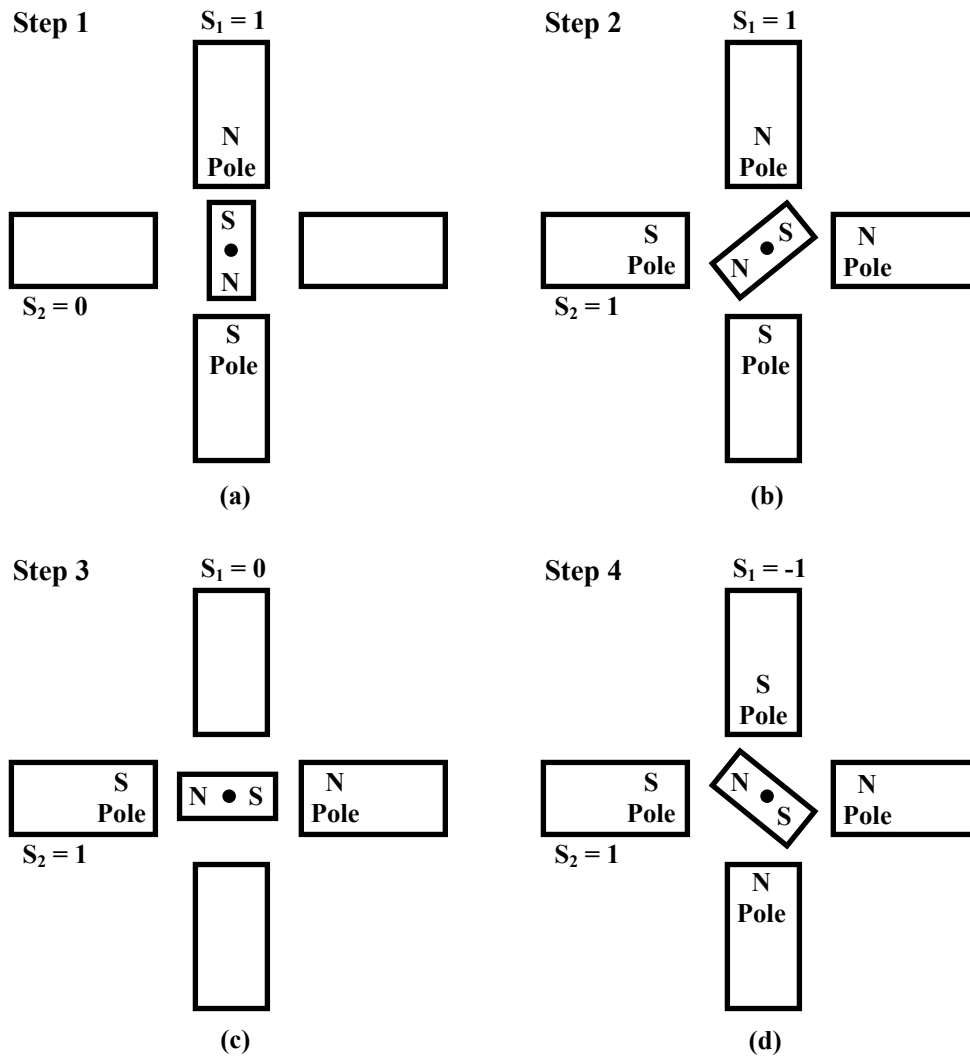

Fig. 3 Stepping sequence (half-stepping) for a two-phase two-pole PM step motor for clockwise rotation.

Table 1
Switching sequence corresponding to the movement shown in Fig.3

	Step 1	Step 2	Step 3	Step 4
Q ₁ -Q ₂	ON (S ₁ =1)	ON (S ₁ =1)		
Q ₃ -Q ₄				ON (S ₁ = -1)
Q ₅ -Q ₆				
Q ₇ -Q ₈		ON (S ₂ =1)	ON (S ₂ =1)	ON (S ₂ =1)

It is apparent from Table 1 and Fig. 3 that for this type of switching the step angle is 45° and it takes 8 steps to complete a complete revolution. So we have 8 steps / revolution. It can also be seen from Table 1 that a pair of switch (say Q₇-Q₈) remains closed during consecutive three steps of rotation and there is an overlap at every alternate step where both the two windings are energised. This arrangement for controlling the step motor movement is known as *half stepping*. The direction of rotation can be reversed by changing the order of the switching sequence.

It is also possible to have an excitation arrangement where each phase is excited one at a time and there is no overlapping where both the phases are energised simultaneously, though it is not possible for the configuration shown in Fig.1, since that will require the rotor to rotate by 90° in each step and in the process, may inadvertently get locked in the previous position. But *full stepping* is achievable for other cases, as for example for the two-phase six-pole permanent magnet step motor as shown in Fig. 4. In this case, the stator pitch $\theta_s = 90^\circ$ and the rotor pitch $\theta_r = 60^\circ$; the full step angle is given by $\theta_{fs} = \theta_s \sim \theta_r = 30^\circ$ and the half step angle $\theta_{hs} = (\theta_s \sim \theta_r) / 2 = 15^\circ$. The desired direction of rotation can be achieved by choosing the sequence of switching.

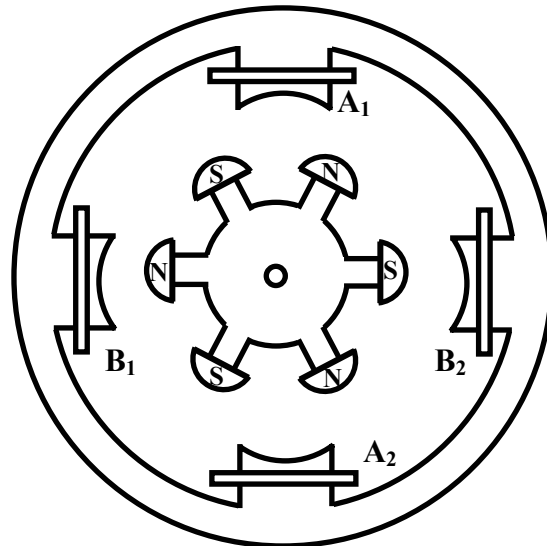

Fig. 4 Two-phase six-pole permanent magnet step motor.

The advantage of a permanent magnet step motor is that it has a *holding torque*. This means that due to the presence of permanent magnet the rotor will lock itself along the stator pole even when the excitation coils are de-energised. But the major disadvantage is that the direction of current for each winding needs to be reversed. This requires more number of transistor switches that may make the driving circuit unwieldy. This disadvantage can be overcome with a variable reluctance type step motor, as explained in the next section.

Another way of reducing the number of switches is to use unipolar winding. In unipolar winding, there are two windings per pole, out of which only one is excited at a time. The windings in a pole are wound in opposite direction, thus either N-pole or S-pole, depending on which one is excited.

Variable Reluctance type Step Motor

Variable reluctance type step motors do not require reversing of current through the coils, but at the same time do not have any holding torque. Compared to permanent magnet step motors, their step angles are also much smaller. Step angle as low as 1.8° can be achieved with this type of motors. Here the rotor is a cylindrical soft iron core with projected teeth. When a particular stator coil is excited, the rotor aligns itself such that one pair of teeth is along the energised stator coil, at the minimum reluctance path. The schematic arrangement of a three phase VR motor with 12 stator poles (teeth) and eight rotor teeth is shown in Fig.5.

When phase-1 is energised, the rotor will align itself as shown in the figure. In the next step, if phase-1 is switched off and phase-2 is switched on, the rotor will rotate in CCW direction by an angle of 15° . This can be understood from the following derivation:

Here the stator pole pitch

$$\theta_s = \frac{360^\circ}{\text{Number of stator pole teeth}} = \frac{360^\circ}{12} = 30^\circ.$$

On the other hand, the rotor pole pitch

$$\theta_r = \frac{360^\circ}{\text{Number of rotor pole teeth}} = \frac{360^\circ}{8} = 45^\circ$$

So the full step angle $\theta_{f.s} = \theta_s \sim \theta_r = 45^\circ - 30^\circ = 15^\circ$.

Similar to the earlier case, we can also have *half stepping* where step angle of 7.5° can be achieved. The switching sequence for rotation in the counter clockwise direction with half stepping would be 1-(1,2)-2-(2,3)-3-(3,1)-1....

Further reduction of step angle is possible by increasing the number of stator and rotor teeth. Besides, multi-stack stators are also used for achieving smaller step angle, where there are several stacks of stator windings skewed from each other by a certain angle. It has been already mentioned that the VR motors do not have any holding torque. It is natural because, when the stator coils are de-energised there is no magnetic force present and the rotor is free. *Hybrid step motors* are improved versions of single stack VR motors, where the basic constructions are modified slightly in order to achieve holding torque. However this part will not be discussed in this lesson. Interested readers may consult the books given in the reference

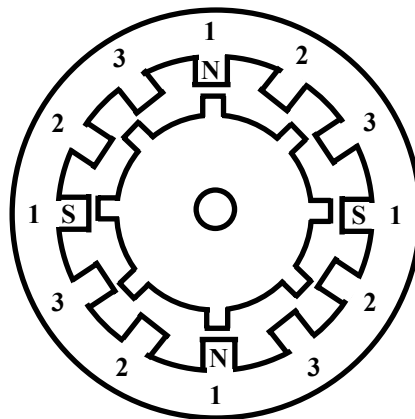

Fig. 5 Three-phase single-stack VR step motor with twelve stator poles (teeth) and eight rotor teeth.

Typical specification of a step motor

4 phase permanent magnet unipolar stepper motor.
Supply voltage: 12V, Power: 5W, Current: 400 mA.
200 steps/revolution, (full step angle- 1.8° , half step angle- 0.9°).
Resistance/ phase: $30\ \Omega$, Inductance/ phase: 23 mH.
Holding torque: 2000 gm-cm, Rotor inertia: $22\ \text{gm-cm}^2$.
Shaft diameter: 5cm.

Driving Circuit

The switches shown in Fig.2 are essential for energising the coils of the step motor. In present day applications, semiconductor switches are universally employed for this purpose. A typical transistor switch arrangement is shown in Fig.6(a). A positive going pulse will turn on the transistor and energise the coil. When the base voltage is withdrawn, the current through the coil stops. A free wheeling diode is normally provided across the coil so that when the current through the coil is suddenly withdrawn, the large induced emf finds a return path for current and its magnitude is reduced. Note that the developed torque would always be restorative, i.e. of signal so that it tends to bring back the rotor to equilibrium, i.e. $\theta = 0$. Now suppose, we give a rectangular pulse to the base of the transistor. Ideally the current through the coil will be as shown by the dotted lines in Fig. 6(b). But the current cannot rise instantaneously due to the presence of inductor and the actual current pulse will be as shown by the continuous line in Fig. 6(b). As a result sufficient torque will be generated only when the current reaches the steady state value. Thus the time constant (T_0) of the winding limits the frequency of switching. For proper operation, the width of each pulse should be at least 6-8 times the time constant of the winding.

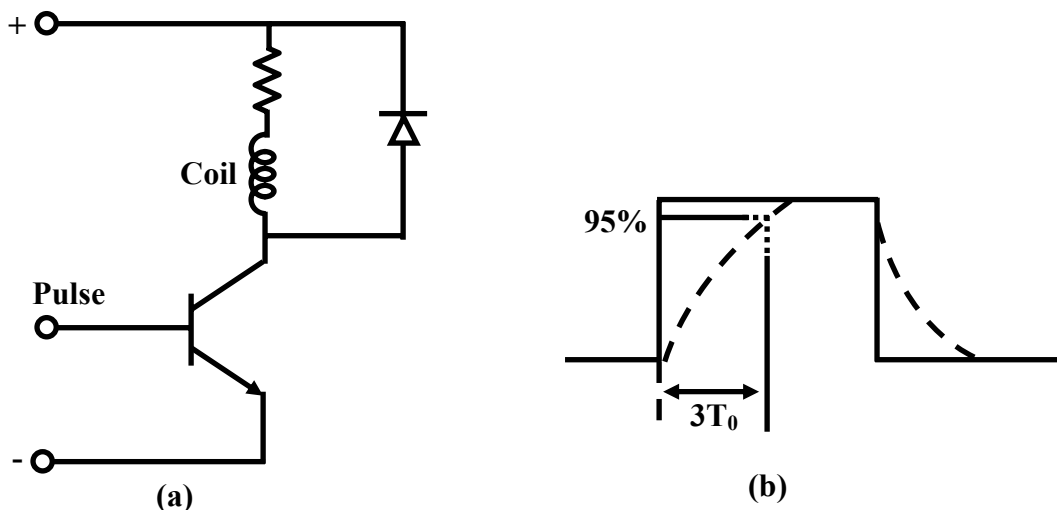

Fig. 6 (a) Driving circuit of a coil (b) Current pulse: line – ideal, dotted - actual

Static Torque Curve

The torque developed in a step motor is not constant and is position dependent. To understand the torque vs. displacement curve, consider a simple three-phase VR type motor with a rectangular rotor as shown in Fig. 7(a). Suppose Phase-1 is excited and the rotor is aligned with its axis ($\theta = 0$). At this position the rotor is not experiencing any torque (otherwise it should have moved, friction is neglected). With phase-1 remaining excited if we now rotate the rotor by hand through $\pm 90^\circ$, it will experience torque as shown in Fig. 7(b). The torque is zero when $\theta = \pm 90^\circ$. In between the torque direction will be +ve or -ve depending on the direction of θ , but the magnitude is not constant. However the zone of operation for phase-1 is limited to $\pm 60^\circ$, since phase-2 or phase-3 takes up on either side. For clockwise operation, suppose the initial rotor position was -60° . If phase-1 is excited, it will bring the rotor to the position $\theta = 0$. If phase-2 is now excited the rotor will rotate clockwise by $+60^\circ$ and settle there.

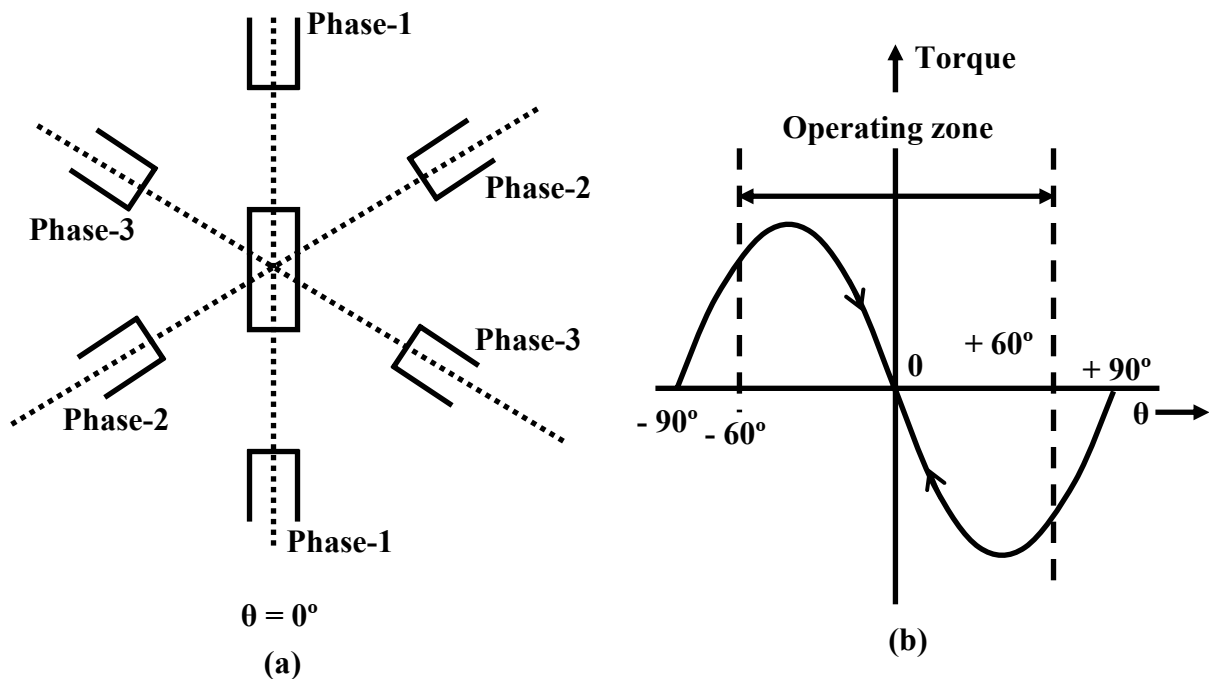

Fig. 7 (a) Three phase two pole VR-type step motor (b) Its torque vs displacement characteristics corresponding to phase-1.

Subsequently phase-3 takes up and the rotor rotates further to $+120^\circ$. The overall torque vs. displacement characteristics is shown in Fig. 8.

Now the number of rotor poles considered above is two. It should be noted that if the number of rotor poles were four, the range of angle for which torque curve will cover a full cycle will reduce to $\pm 45^\circ$ and the operating zone for each phase will reduce to $\Delta\theta = 30^\circ$ for clockwise rotation, where $\Delta\theta$ is the full step angle. Thus the operation of each phase in the torque-displacement characteristics in Fig. 8 is shown to be $\Delta\theta$. But the curve corresponding to excitation of only one phase for each phase will be sinusoidal in nature.

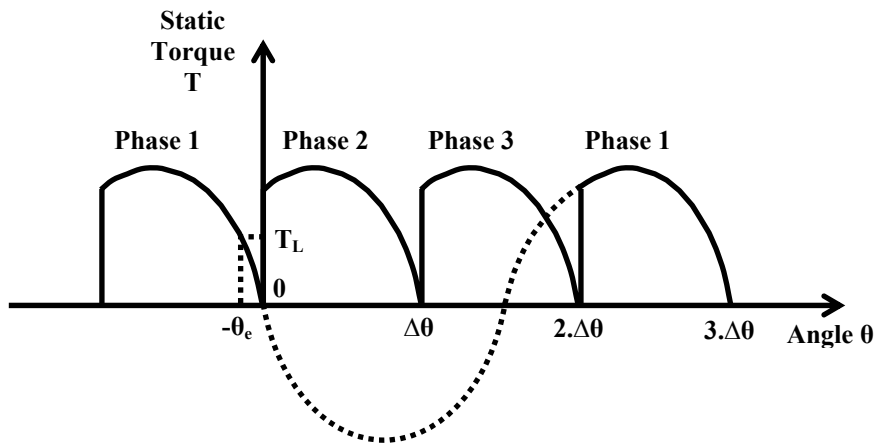

Fig. 8 Periodicity of the single-phase static torque distribution (a three-phase example).

Static Position Error

Consider the static torque characteristics corresponding to phase -1, as shown in Fig. 9. Under ideal condition, the equilibrium position in Fig. 9 is zero. However if there is a static load torque T_L is present, the equilibrium point will shift to $-\theta_e$, since beyond this point the torque generated will not be sufficient to overcome the static load torque. Thus there will be a static position error of θ_e . Assuming the torque angular displacement curve is sinusoidal, it can be shown that:

$$\theta_e = \frac{p}{n} \sin^{-1} \left(\frac{T_L}{T_{\max}} \right) \quad (1)$$

where p = number of phases, n = number of steps/ revolution and T_{\max} is the maximum torque generated..

Thus more the number of steps/ revolution (smaller step angle) less will be the static position error.

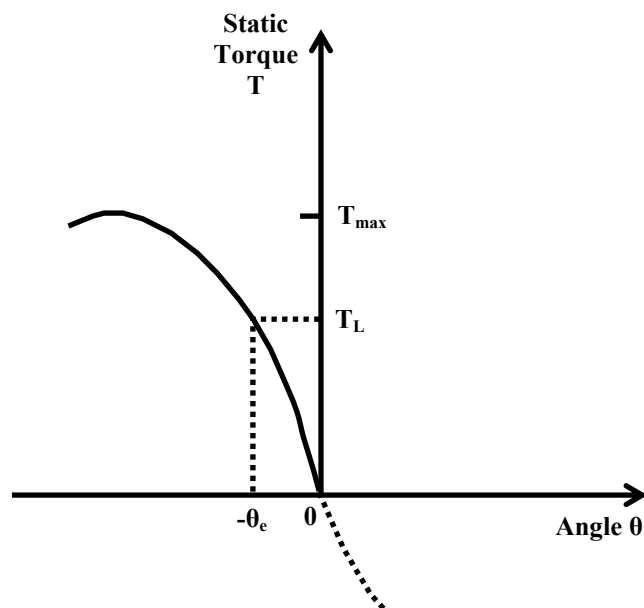

Fig. 9 Representation of the static position error.

Dynamic Response

So far we have discussed about the static performance of step motor. Now we examine how the motor behaves under dynamic condition. Ideally the rotor of a step motor should rotate by step angle once it receives a pulse and the rotation should occur instantaneously. But due to the inertia of the rotor, the rotor cannot settle down at its final position instantaneously and it undergoes through some oscillations as shown in Fig.10. Before settling down after some time. The overshoot increases if the inertia of the rotor is large. This will cause large settling time. In order to decrease the overshoot, additional damping arrangement is sometimes provided. The damping can be in the form of (a) viscous damping, (b) eddy current damping and (c) electronic damping. However the details of the damping arrangements are not discussed in this lesson.

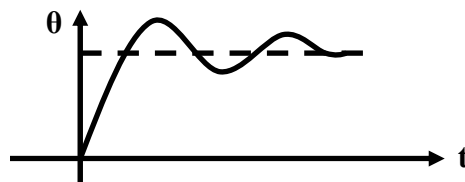

Fig. 10 Dynamic Response of a Step motor

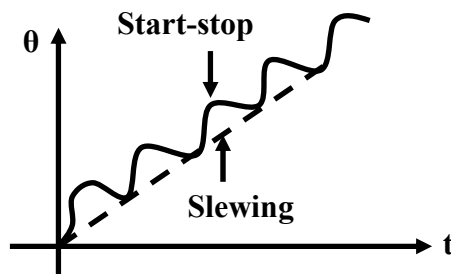

Fig. 11 Start-stop and slewing mode of operation

Continuous Operation

It has been mentioned earlier that though the step motors are normally used for discrete step operations, they can be used for continuous rotation also. A train of control pulses will rotate the motor continuously. Continuous operation can be achieved in two ways: *start-stop* and *slewing mode* of operation. In the first case, one pulse is applied, the rotor rotates through one step, settles at its stable location and then another pulse is sent to rotate it by one more step. Thus in each step the rotor comes to a halt before the next pulse is received. On the other hand, the pulses received are at much faster rate in slewing mode and the control circuit generates a pulse before the rotor comes to a steady state. As a result, the rotor runs at uniform speed without stopping after each step. The inertia effect is absent because of the continuous rotation and the motor can take more load when it is slewing. The displacement vs. time characteristics in start-stop and slewing modes are shown in Fig.11. The torque vs. speed characteristics under these two modes have been shown in Fig.12. From this figure it is clear that at a particular speed the torque generated in slewing mode is more in slewing mode.

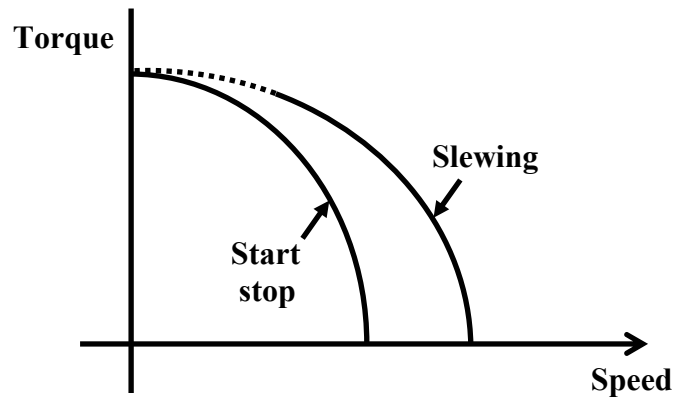

Fig. 12 Torque-speed characteristics for continuous running.

But there is a problem if we want to start a motor with load under slewing operation. When a motor starts with load, it cannot suddenly start rotating at high speed. It has to be accelerated gradually by increasing the number of steps/sec. This process of starting and acceleration is known as *ramping*.

Control of Step Motors

In many cases step motors are used for accurate positioning of tools and devices. Precision control over the rotation of the motor is required for these cases. Control of step motors can be achieved in two ways: open loop and closed loop. The open loop control is simpler and more widely used, such a scheme is shown schematically in Fig.13. The command to the pulse generator sets the number of steps for rotation and direction of rotation. The pulse generator correspondingly generates a train of pulse. The Translator is a simple logical device and distributes the position pulse train to the different phases. The amplifier block amplifies this signal and drives current in the corresponding winding. The direction of rotation can also be reversed by sending a directional pulse train to the translator. After receiving a directional pulse the step motor reverses the direction of rotation.

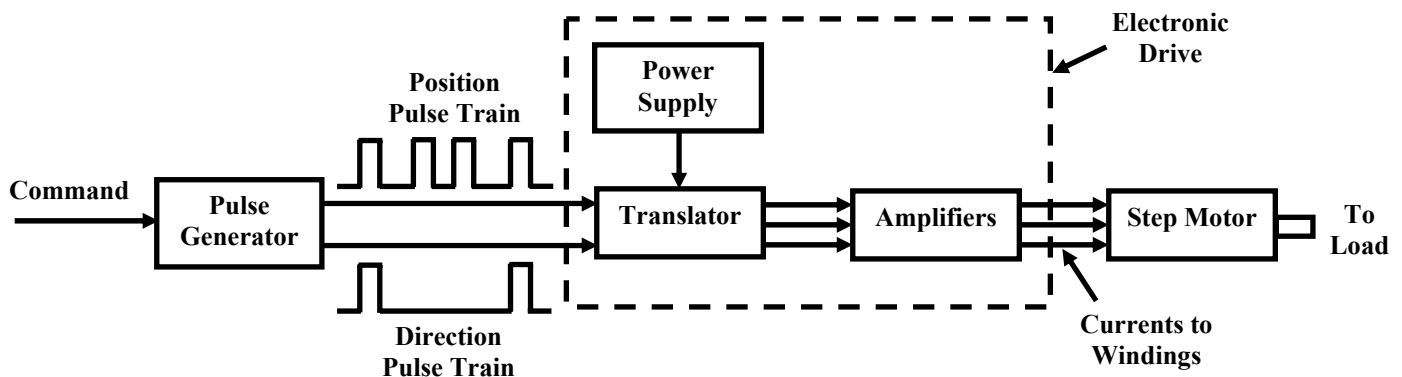

Fig. 13 Open-loop control of a step motor.

The major disadvantage of the open loop scheme is that in case of a missed pulse, there is no way to detect it and correct the switching sequence. A missed pulse may be due to

malfunctioning of the driver circuit or the pulse generator. This may give rise to erratic behaviour of the rotor.

In this sequel the closed loop arrangement has the advantage over open loop control, since it does not allow any pulse to be missed and a pulse is sent to the driving circuit after making sure that the motor has rotated in the proper direction by the earlier pulse sent. In order to implement this, we need a feedback mechanism that will detect the rotation in every step and send the information back to the controller. Such an arrangement is shown in Fig. 14. The incremental encoder here is a digital transducer used for measuring the angular displacement.

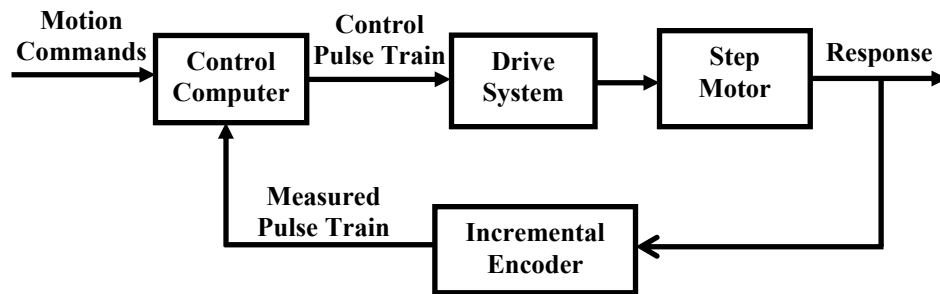

Fig. 14 Feedback control of a step motor.

Conclusion

Step motors find wide applications as an electrical actuator. It can be readily interfaced with a computer and can be controlled for rotation at a very small angle, or a precisely determined speed. Step motors nowadays can deliver large torque also. These are the reasons step motors are gradually replacing conventional a.c. and d.c. motors in many cases. The constructions, principles of operation and driving schemes used for step motor have been discussed in this lesson. Both the open loop and close loop control schemes for position control of step motors have been elaborated. The torque characteristics of a step motor is distinctly different from conventional motors and nonlinear in nature. As a result it is not possible even to develop a linearised transfer function model of a step motor (a practise that is common for a.c. and d.c. servomotors). This is possibly a major hindrance for modelling and simulation of systems with step motor drives.

References

1. C.W. de Silva: *Control Sensors and Actuators*, Prentice Hall, New Jersey, 1989.
2. T. Wildi: *Electrical Machine Drives and Power Systems*

Review Questions

1. Indicate the correct answer:
 - (a) The major advantage of a permanent magnet step motor is that it can provide holding torque (True/ False).
 - (b) The torque generated in a step motor under start-stop mode is more than under slewing mode (True/ False).

- (c) A variable reluctance type step motor requires less number of switches than of permanent magnet type (True/ False).
- (d) Ramping of a step motor refers to slow acceleration during starting (True/ False).
- (e) 3-phase a.c. excitation is needed to drive a 3-phase step motor (True/ False).
2. A step motor has 130 steps per revolution. Find the input digital pulse rate that produces continuous rotation at a speed of 10.5 revolutions/ sec.
 3. The inductance and resistance of each phase winding of a step motor are 10 mH and 2Ω respectively. The switching arrangement has been designed that each phase receives a pulse of duration 10 msec. Is the arrangement satisfactory? Justify your answer.
 4. Write down the switching sequence for the step motor shown in Fig. 4 for clockwise rotation with full stepping.
 5. Consider the VR type step motor shown in Fig. 5. The switching sequence of the phase winding is 1-3-2-1. Find the direction of rotation and the step angle.
 6. What is meant by static position error of a step motor? How can it be reduced?
 7. Discuss the limitations of open loop type control of step motors.
 8. Can a BLDC motor replace a step motor for incremental motion? What would be the advantages and limitations?
 9. Can a step motor replace a BLDC motor for controlled speed drive?

Answer

1. (a) True, (b) False, (c) True, (d) True, (e) False.
2. 1365 pulse/sec.
3. Pulse duration should be at least 30 msec.
5. 15° clockwise direction.

Source:[http://www.nptel.ac.in/courses/Webcourse-contents/IIT%20Kharagpur/Industrial%20Automation%20control/pdf/L-32\(SS\)\(IAC\)%20\(\(EE\)NPTEL\).pdf](http://www.nptel.ac.in/courses/Webcourse-contents/IIT%20Kharagpur/Industrial%20Automation%20control/pdf/L-32(SS)(IAC)%20((EE)NPTEL).pdf)