

Module

4

Lighting Application

Lesson

17

Road Lighting

Instructional objectives

1. List factors affecting Road lighting scheme.
2. State the conditions provided by Road lighting.
3. List the categories of Road and recommended light levels.
4. Understand zones in a tunnel lighting.
5. What are Post Top Lanterns?

Road Lighting

Road lighting provides visual conditions for safe, quick and comfortable movement of Road users.

The factors responsible for the lighting scheme for roads are:

- i. Luminance Level.
- ii. Luminance Uniformity.
- iii. Degree of Glare limitation.
- iv. Lamp Spectra and
- v. Effectiveness of visual guidance.

Luminance Level

As the Luminance of a road influences contrast sensitivity of drivers' eyes and contrast of obstacles, relative to back ground. Hence affects performance of Road users. Surrounding brightness affects the adaptation of human eye. Bright surroundings lower contrast sensitivity there by requiring higher luminance for the road surface. Darker surroundings make driver adapted to road (assuming road is brighter). Roads with dark surrounds are to be lit by including surroundings. Otherwise drivers cannot perceive objects in the surroundings. CIE 12 recommends that 5m away from the road on either side should be lit by illuminance level at least 50% of that on the road.

Luminance Uniformity

Adequate uniformity is necessary for visual performance and visual comfort of the user. From visual performance view point, uniformity ratio is defined by $U_0 = L_{\min} / L_{\text{avg}}$. U_0 should not be below 0.4. From visual comfort view point uniformity ratio is defined as $U_1 = L_{\min} / L_{\max}$ measured along the line passing through the observer positioned in the middle of the traffic facing the traffic flow. Termed longitudinal uniformity ratio.

Glare Limitation

Physiological or disability glare affect visual performance. Psychological or discomfort glare affect visual comfort. Glare is to be avoided at all costs.

Lamp Spectra

Spectral composition determines color appearance of the lamp. The way lamp is going to render color to objects Low pressure sodium vapour lamps give greater visual acuity. Spectrum should be such; there is Great speed of perception, less discomfort glare and shorter recovery time after glare.

Visual Guidance

Visual guidance guides the road user and hence must for user to get a recognizable picture of the course immediately. This is improved by lamp arrangement that follows the run of the road. More so if turns and intersections are there. Lighting scheme must provide visual guidance. On roads having separate lanes with a separator the lighting columns are located on the separator. As is the custom in large avenues in Metros. On a curve the lighting column is located along the outer column. This gives a clear indication of the run of the road on the curvature. Visual guidance pilots traffic through lights of different colors on different routes. Exits on main roads are lit differently. Sodium vapour lamps for the main road and mercury lights for exits are employed.

Official Recommendations

National standards are taken from CIE 12. Visual conditions for smooth movement and safe traffic pattern. They depend on speed, intensity, composition of traffic and complexity of the road.

Table I lists the categories of the road as A to E based on the locality and traffic density. Table II lists the appropriate recommendations for lighting.

Road categories

Table I

Category	Type and density of traffic	Type of Road	Examples
A	Heavy and high speed motorized traffic.	Road with separators. No crossings. Complete access control	Motorway Expressway
B		Important traffic road for motorized traffic only. Separate road for slow traffic/pedestrian.	Trunk road Major road
C	Heavy and moderate speed motorized traffic or heavy mixed traffic of moderate speed.	Important all purpose rural or urban road	Ring road Radial road
D	Fairly heavy mixed traffic of which a major part may be slow traffic or pedestrians.	Roads in City or shopping centers, approach roads motorized traffic meets heavy slow or pedestrians.	Trunk road Commercial road Shopping streets etc.
E	Mixed traffic of limited speed and moderate	Collector road between residential areas	Collector road Local streets.

Recommendations for lighting

Table II

Category	Surrounds	Luminance level. Average road surface luminance $L_{av}(Cd/m^2)$ \geq	Uniformity road	
			Overall Uniformity ratio U_0 \geq	Lengthwise Uniformity ratio U_1 \geq
A	Any	2	0.4	
B1	Bright	2		0.7
2	Dark	1	0.4	
C1	Bright	2	0.4	
2	Dark	1	0.4	0.5
D	Bright	2	0.4	0.5
E1	Bright	1	0.4	0.5
2	Dark	0.5	0.4	0.5

Lighting Arrangements

Depending on the road category there are various arrangements for two way traffic roads. They are four types as shown in Fig. 1. They are:

- Single sided – located on one side, if width of the road \leq mounting height. Luminance at the opposite remote end lower than under the lamp.
- Staggered – located on either side of the road in a staggered or zigzag fashion when width is 1 – 1.5 times the mounting height. Here care is to be taken to avoid dark patches.
- Opposite – located opposite one another. When width is greater than 1.5 times the mounting height.
- Span wire – luminaires suspended along the axis of the road only normally for narrow roads. Suspended from cables strung between buildings.

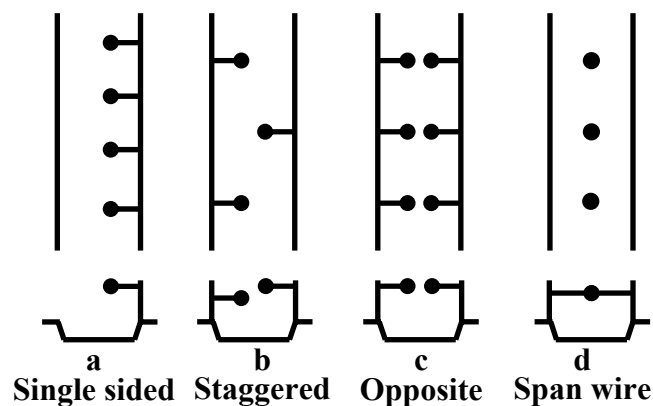

Fig. 1 Lighting arrangement for 2 way street

High speed ways and dual lanes lamps may be located on the separator and are termed central twin bracket arrangement. As shown in Fig 2.

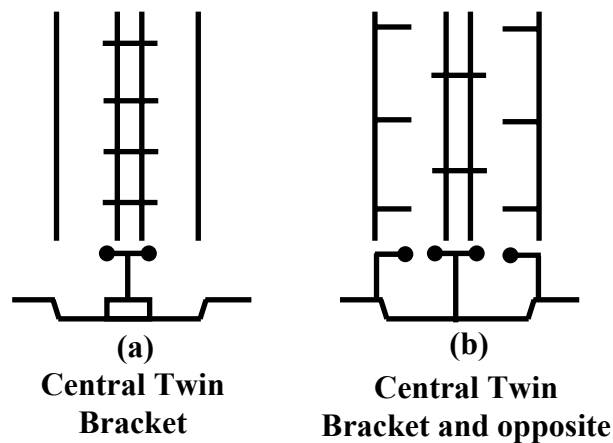

Fig. 2 Lighting arrangement on the 2 Lane Roads.

Road Junctions

Special care is taken at road junctions as shown in Figs. 3 and 4. Care is taken such that junction is clearly visible from a distance. Should prevent traffic congestion. Higher luminance at junction. Using different colors at the junction. Different arrangements be for main roads and secondary roads. High mast lighting preferred at junctions.

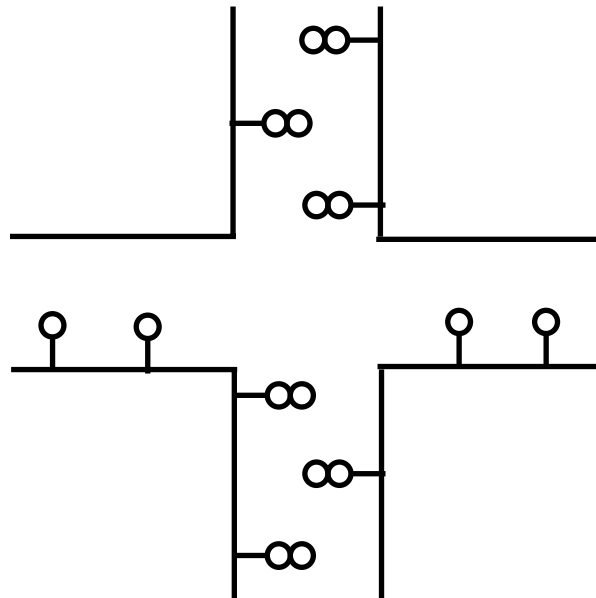

Fig. 3 Crossing of major and minor roads roads.

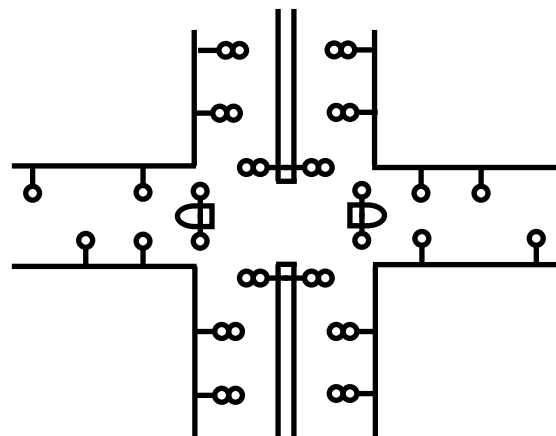

Fig. 4 Crossing on a two lane highway.

Curves

Special care is taken on curves. On radius larger than 300m, the curve can be treated as straight roads. Smaller radius curves, lamps are located outside of the curve. Smaller the radius, closer is the spacing. Usually 0.5 – 0.25 times that for a straight road.

Tunnel lighting

Tunnels need to be lit both during day and night. Sense of safety same as on open road. Tunnel for this purpose is divided into five zones Access zone, Threshold zone, Transition zone, Interior zone and Exit zone. Access zone is immediately outside the tunnel, where driver must be able to detect obstacles in the tunnel. Threshold zone is first of the four zones driver in the access zone must detect, obstacles in this zone before entering the tunnel. Length depends on the maximum speed and corresponding stopping distance. Transition zone is where levels can be gradually reduced. This is where reduction takes place. Interior zone is the Tunnel stretch farthest from influence of day light. Only artificial light enables drivers' vision in this zone. Level is constant throughout depending on the speed, here highest level is chosen. Exit zone where vision is influenced by the brightness outside. Tunnels need extra day time lighting when tunnels are very long. CIE recommendation, including various aspects, needs at least for tunnel lengths.

Tunnel lengths < 25m – no day time lighting, 25 – 125m – 50% normal threshold zone lighting and >125m – normal threshold zone lighting . Fig. 5 shows Tunnel lighting levels as a function of tunnel length.

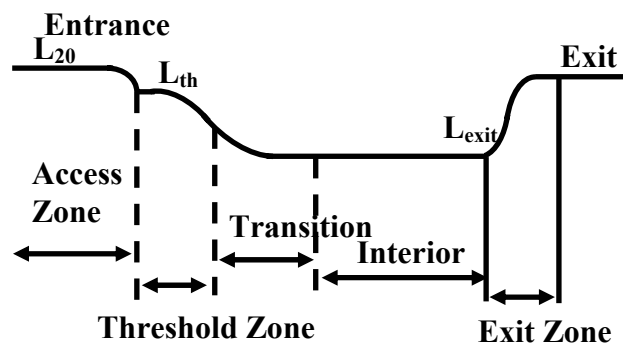

Fig. 5 Tunnel lighting levels

Tunnel lighting employs transverse and longitudinal light distributions which are symmetrical and counter beam system, which is asymmetrical. Transverse light radiated at 90° to the axis of the tunnel may be continuous line of tubular fluorescent lamps that give good visual guidance, minimal glare and require simple switching. Only disadvantage is close spacing. Longitudinal – light radiated parallel to the tunnel axis. It leads to high efficacy and large luminaire spacing. Counter beam is light radiated parallel to the tunnel axis against the direction of traffic flow. In Residential area, road safety, security and amenity are kept in mind. Where only pedestrians are there, security and amenity are major criteria. In such areas high pressure mercury vapour lamps or blended lamps are preferred. Sodium vapor lamps of 50 / 70W have been successfully used. Wherever light needs to serve pedestrians post top lanterns are preferred.

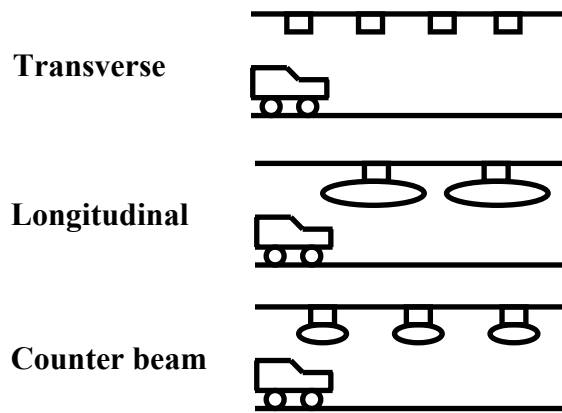

Fig. 6 Scheme for Tunnel lighting.

Summary

- Road lighting aims safe, quick and comfortable movement of traffic.
- There are five categories of Roads, A, B, C, D and E depending on the type and density of traffic.
- Mostly sodium vapor lamps are preferred on the roads.
- At junctions mercury vapor lamps may be provided.
- Tunnel lighting needs to be carried out in such a way as to gradually change the light level. Tunnels lit during the day as well as night.
- Residential areas have post top lanterns.

Tutorial Questions

- What are the factors responsible for road lighting?
- What are the various arrangements of locating lamps on roads?
- What are the various categories of the roads?
- List the various zones in a Tunnel from lighting view point
- What are the various schemes employed for tunnel lighting?

Answer to Questions of previous lecture

- Where do we use narrow beam flood lights?
Narrow beam flood lights have higher light flow. So they are used where greater distances are involved.
- Where do we use wide beam flood lights?
Wide beam flood lights have lower intensity. So they are used where large areas are involved.
- Why are lamps used for sports lighting operated at higher voltage than rated voltage?
A small increase in voltage produces higher light output & comparatively less increase in power consumption. Hence they are operated with voltage greater than rated voltage