

Implementation of Prototype Device – Off Grid - Charge Controller – Suitable for Wind Solar Hybrid

¹Geeta Laxmanrao Kale, ²N.N. Shinde

^{1,2}Dept. of Energy Technology, Shivaji University, Kolhapur, India

Abstract

A Hybrid renewable energy system utilizes two or more production methods, usually solar and wind power. A Charge Controller is a device that controls the flow of current to and from the battery subsystem to protect the batteries from overcharge and over discharge. There are different types of charge controllers such as Analog series/shunt mode charge controller, ON/ OFF charge controller, Pulse Width Modulation technique based charge controller are having efficiencies of 60% to 70%, 65% to 75% and 75% to 85% respectively. The MPPT types are newly introduced and are latest trend in market. They are more costly and better suited to large systems. The MPPT charge controllers charges the battery at full power by maintaining efficiency of 90% to 93%. Among all discussed charge controllers, the MPPTs provide excellent efficiency however they are costly.

The main disadvantage of existing type of circuitry is that their efficiency is very low as the circuits do not consider input power and output power. Thus any mismatch between input and output power may lead to loss of power resulting in lower efficiency. The status of charged battery can be known only from LED displays. Thus the actual battery voltage cannot be known. The system cannot be used for large current applications. Actual battery voltage cannot be monitored. The analog ICs have been implemented which are not intelligent devices. To overcome disadvantages of above said analog system the proposed system is developed. This system will use microcontroller which is an intelligent device, it will switch ON and OFF the MOSFET according to status of battery (whether fully charged or discharged). In addition it will also display the present voltage on battery indicating actual status of battery.

Keywords

Hybrid renewable energy system, Charge controller, MPPT algorithm, microcontroller intelligent device and MOSFET.

I. Introduction

A Hybrid renewable energy system utilizes two or more production methods, usually solar and wind power. The major advantage of Solar/wind hybrid system is that when Solar and Wind power production are used together, the reliability of the system is enhanced. Additionally, the size of battery storage can be reduced as there is less reliance on one method of power production, often when there is no Sun, there is wind.

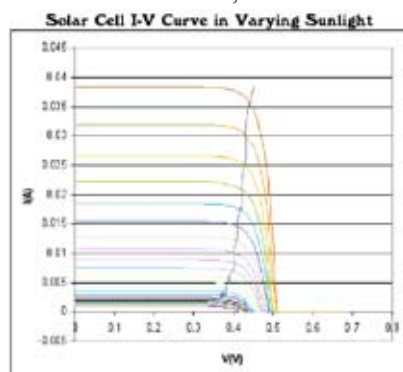

Fig.1 : Solar cell I-V characteristics

PV cells have a single operating point where the values of the current (I) and Voltage (V) of the cell result in a maximum power output. These values correspond to a particular load resistance, which is equal to V/I . PV cell has an exponential relationship between current and voltage, and the maximum power point (MPP) occurs at the knee of the curve, where the resistance is equal to the negative of the differential resistance ($V/I = -dV/dI$). Maximum power point trackers utilize control circuit or logic to search for this point and thus to allow the converter circuit to extract the maximum power available from a cell.

At night, an off-grid PV power system uses batteries to supply its loads. Although the battery pack voltage when fully charged may be close to the PV array's peak power point, this is unlikely to be true at sunrise when the battery is partially discharged. Charging may begin at a voltage considerably below the array peak power point, and MPPT can resolve this problem.

When the batteries in an off-grid system are full and PV production exceeds local loads, a MPPT can no longer operate the array at its peak power point as the excess power has nowhere to go. The MPPT must then shift the array operating point away from the peak power point until production exactly matches demand. In a grid-tied photovoltaic system, the grid is essentially a battery with near infinite capacity. The grid can always absorb surplus PV power, and it can cover shortfalls in PV production (e.g., at night). Batteries are thus needed only for protection from grid outages. The MPPT in a grid tied PV system will always operate the array at its peak power point unless the grid fails when the batteries are full and there are insufficient local loads. It would then have to back the array away from its peak power point as in the off-grid case.

MPPTs can be designed to drive an electric motor without a storage battery. They provide significant advantages, especially when starting a motor under load. This can require a starting current that is well above the short-circuit rating of the PV panel. A MPPT can step the panel's relatively high voltage and low current down to the low voltage and high current needed to start the motor. Once the motor is running and its current requirements have dropped, the MPPT will automatically increase the voltage to normal. In this application, the MPPT can be seen as an electrical analogue to the transmission in a car; the low gears provide extra torque to the wheels until the car is up to speed. The proposed charge controller will monitor the battery voltage continuously. Whenever the battery reaches the lower threshold point, immediately the microcontroller will start charging the battery. The microcontroller will periodically monitor and charge the battery. On arrival at upper threshold voltage it will disconnect the battery means it will switch OFF the MOSFET so that no battery charging will take place. The system utilizes P&O method under MPPT scheme.

The power curve of a wind turbine follows this relationship between cut-in wind speed (the speed at which the wind turbine starts to operate) and rated capacity, the wind turbine usually reaches rated capacity, at a wind speed between $12-16 \text{ ms}^{-1}$, depending on the design of the individual wind turbine.

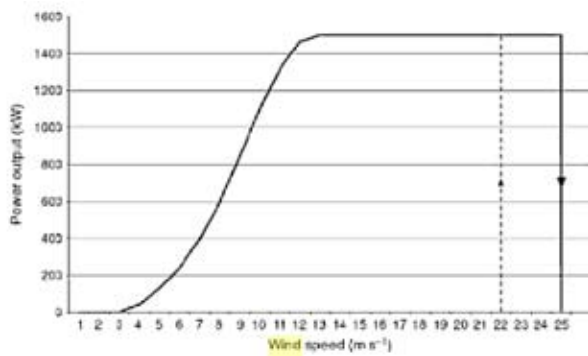

Fig. 2 : Typical power curve of a 1500 KW pitch regulated wind turbine with a cut-out speed of 25 ms^{-1} (the broken line shows hysteresis effect)

At wind speeds higher than the rated wind speed, the maximum power production will be limited, or other words, some parts of the available energy in the wind be "spilled". The power output regulation can be achieved with pitch- control (i.e. by feathering the blades in order to control the power) or with stall control (i.e. the aerodynamic design of the rotor blade will regulate the power of the wind turbine) Hence a wind turbine produces maximum power within a certain wind interval that has its upper limit at the cut-out wind speed. The cut-out wind speed is the wind speed where the wind turbine stops production and turns out of the main wind direction. Typically, the cut-out wind speed is in the range of 20 to 25 ms^{-1} .

The power curve depends on the air pressure (i.e. the power curve varies depending on the height above Sea level as well as changes in the aerodynamic shape of the rotor blades, which can be caused by dirt or ice) The power curve of fixed speed, stall-regulated wind turbines can also be influenced by the power system frequency. A Charge Controller is a device that controls the flow of current to and from the battery subsystem to protect the batteries from overcharge and over discharge. The Charge Controller may also monitor system performance and provide system protection. Charge Controller limits the rate at which electric current is drawn from the modules. Thus charge controller circuitry regulates flow of current by monitoring the battery voltage continuously. It is used to manage the electrical power produced by the modules, protect the batteries and to act as a connection point for all the system components.

There are different types of charge controllers such as Analog series/shunt mode charge controller, ON/ OFF charge controller, Pulse Width Modulation technique based charge controller of efficiencies 60% to 70% , 65% to 75% and 75% to 85% respectively. The MPPT types are newly introduced and are latest trend in market. They are more costly and better suited to large systems. The MPPT charge controllers charges the battery at full power by maintaining efficiency of 90% to 93% . Among all discussed charge controllers, the MPPTs provide excellent efficiency however they are costly.

The main disadvantage of existing type of circuitry is that their efficiency is very lower as the circuits do not consider input power and output power. Thus any mismatch between input and output power may lead to loss of power resulting in lower efficiency. The status of charged battery can be known only from LED displays. Thus the actual battery voltage cannot be known. The system cannot be used for large current applications. No display has been connected so that actual battery voltage cannot be monitored.

The analog ICs have been implemented which are not intelligent devices. To overcome disadvantages of above said analog system

the proposed system is developed. This system will use microcontroller which is an intelligent device, it will switch ON and OFF the MOSFET according to status of battery (whether fully charged or discharged). In addition it will also display the present voltage on battery indicating actual status of battery.

II. Research Work

A. Charge Controller Survey

1. It provides a central point for connecting the load, module and the battery.
2. It manages the system so that the harvested electricity is effectively used. Batteries like to be charged within a certain voltage range and regular undercharging or overcharging doesn't serve them well. So that components especially batteries are protected from damage due to overcharge, deep discharge and changing voltage level.

B. Types of Charge Controller

Charge Controller regulates the charge transfer and prevents the battery from being excessively charged and discharged. Three types of Charge controllers are commonly used.

1. Series charge Regulators
2. Shunt charge Regulators
3. DC-DC converter

Various types of charge controllers are available. Analog type charge controllers include operational amplifiers which indicate the battery status by glowing the LED. The status of battery can be known by LED. Most of the analog charge controllers glow RED LED for battery discharge and GREEN LED for battery charging.

ON/OFF charge controllers simply make ON and OFF the controlling element like MOSFET so that either full or no current will be passed to the battery.

PWM (pulse-width modulated) charge controllers which charge the battery with constant voltage or constant current are also being used. They have a power device like MOSFET which is made ON and OFF. The efficiency of PWM charge controllers is higher than analog and simple ON/OFF charge controllers. PWM have ability to recover battery capacity, to increase charge acceptance of the battery. The PWM based charge controllers provide longer battery life, saves the cost by reducing size.

The MPPT types are newly introduced and are latest trend in market. They are more costly and better suited to large systems, when the investment in an expensive MPPT regulator gives quick returns. The MPPT charge controllers charges the battery at full power by maintaining efficiency of 90% to 93% . Among all discussed charge controllers in this report, the MPPTs provide excellent efficiency however they are costly [1].

C. Efficiency of different types of charge controller

Table 2 : Efficiency of different types of charge controller.

Sr. No.	Type of charge controller	% Efficiency
1	Analog series/shunt mode charge controller	60% to 70%
2	ON/ OFF charge controller	65% to 75%
3	Pulse Width Modulation technique based charge controller	75% to 85%
4	MPPT technique based charge controller	Above 90%

D. Disadvantages of existing analog charge controller-

1. The main disadvantage of this type of circuitry is that their efficiency is very low as the circuits do not consider input power or output power. Thus any mismatch between input and output power may lead to loss of power resulting in low efficiency.
2. The status of charged battery can be known only from LED displays.
3. The system cannot be used for large current applications.
4. No display has been connected so that actual battery voltage cannot be monitored.
5. The analog ICs have been implemented which are not intelligent devices.

To overcome disadvantages of above said analog system the proposed system is developed. This system will use microcontroller which is an Intelligent device, it will switch ON and OFF the MOSFET according to status of battery (Whether fully charged or discharged). In addition it will also display the present voltage on battery indicating actual status of battery.

E. Advantages of proposed system over existing system

1. The system uses MPPT algorithm hence the efficiency of the system is higher.
2. 16 X 2 LCD display have been interfaced hence battery voltage can be displayed on it. The user will be informed regarding battery status.
3. The system shall be designed for large current ratings in Ampere.
4. Microcontrollers are implemented which are intelligent chips. Hence the system can be modified as per the need of application.
5. Use of microcontroller ensures reliability of the system.
6. The system is user friendly hence can be easily operated by users.
7. System will be compact and handy.

F. Disadvantages of proposed system over existing system

1. The system is costly as compared to existing analog charge controllers.
2. Programming of microcontrollers is required which increases the software cost and creates complexity at the time of making prototype.
3. Computers are needed to write and burn the software in microcontrollers.

Even though system is costly as compared to analog charge controllers, it provides higher efficiency, user friendliness and more accuracy in controlling the MOSFET. Hence for reliable working the proposed charge controllers can be used.

Solar wind power is uncertain sources of power as the generated power is the output which depends upon atmospheric conditions. Solar insolation and wind flow are functions of earth rotations around itself and sun respectively. However for sustained power generation, combination of solar radiation and wind can be one of the source. When output of solar / winds are connected to the battery bank directly in the system. The behavior and design of energy storage devices and energy sources are different and need to be synchronized for optimal power output.

G. Charge controller circuit block diagram

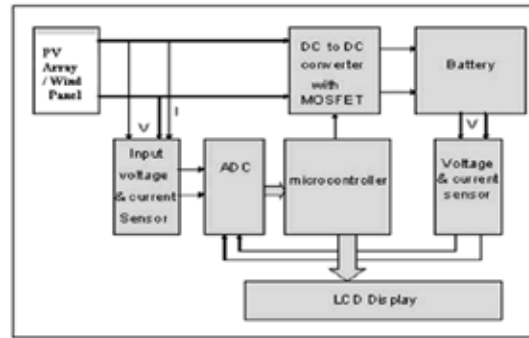

Fig.3 : reveals charge controller circuit block diagram.

Microcontroller chip P89V51RD2 is an intelligent digital chip. It continuously monitor the battery output voltage and makes ON and OFF the MOSFET STP75NF75. Voltage and current circuitry which uses OPAMP IC, resistors and capacitors is implemented. The output of voltage and current circuit is given to ADC. IC 0809, which is converted analog voltage and current to digital values. Microcontroller is read digital values at ADC output and takes the necessary action to charge the battery voltage. In addition it continuously indicates the battery voltage on LCD display.

H. DC – DC Converter Diagram

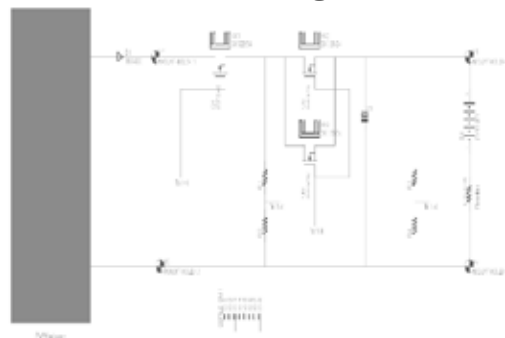

Fig.4 :

I. Software Flow

The software for microcontroller is written in assembly language/ embedded C language of MCS-51[20, 21] microcontroller. The flow chart is explained below.

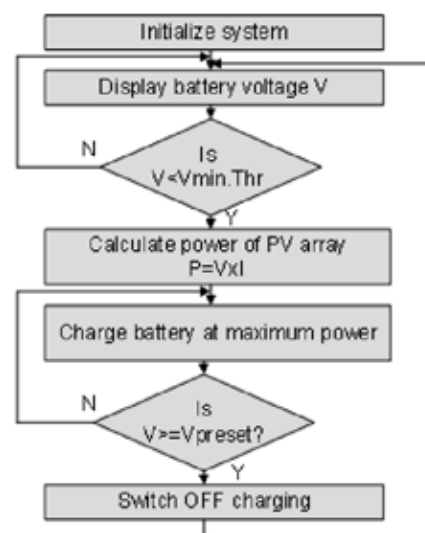

Fig. 5 : Software design

The microcontroller shall display “Charge controller on LCD display. It monitors the battery voltage and displays it on display panel. When battery voltage drops below lower threshold voltage it measure amount of current and voltage of input PV cell/ wind panel and it switch ON the MOSFET so that battery get charged through MOSFET. When battery voltage reaches upper threshold voltage it makes OFF the MOSFET so that charging stopped.

III. Conclusion

The charge controller looks at the output of the panels, and compares it to the battery voltage. It then fig.s out what is the best power that the panel can put out to charge the battery. It takes this and converts it to best voltage to get maximum current into the battery. Efficiency of charge controller varies widely depending weather, temperature, battery state of charge etc.

Reference

- [1] C. Liu, B. Wu and R. Cheung, “Advanced algorithm for MPPT control of photovoltaic systems”, Canadian solar buildings conference, Montreal, August 2004
- [2] V. Salas, E. Olias, A. Barrado, A. Lazaro, “New algorithm applied to maximum power point tracking without batteries”, 21st European photovoltaic solar energy conference, September 2006
- [3] Roberto Faranda, Sonia Leva, “Energy comparison of MPPT techniques for PV systems”, WSEAS transactions on power systems,
- [4] Yen-Jung Mark Tung, Aiguo Patrick Hu, Nirmal-Kumar Nair, “Evaluation of microcontroller based maximum power point tracking methods using dSPACE platform”, Australian university power engineering conference, 2006
- [5] M.S. Ait Cheikh, C. Larbes, G.F. Tchoketch Kebir, A. Zerguerras, “Maximum power point tracking using a fuzzy logic control scheme”, Revue des Energies Renouvelables Vol. 10 N°3 (2007) 387 – 395
- [6] H P Garg and J Prakash, “Solar Energy” Tata McGraw-Hill Publishing Company Limited.
- [7] G.D. RAI, “Non-Conventional Energy Sources” Khanna Publishers.
- [8] S.RAO, Dr. B.B.Parulekar, “Energy Technology” Khanna Publishers.
- [9] Tom P. Hough, “Solar Energy” New Research Nova Science publishers, Inc, New York.
- [10] [Online] Available : <http://www.inwea.org/>
- [11] [Online] Available : <http://www.mnre.gov.in/>