

Cotter and knuckle joint

Instructional Objectives

At the end of this lesson, the students should have the knowledge of

- A typical cotter joint, its components and working principle.
- Detailed design procedure of a cotter joint.
- A typical knuckle joint, its components and working principle.
- Detailed design procedure of a knuckle joint.

4.2.1 Cotter joint

A cotter is a flat wedge-shaped piece of steel as shown in **figure-4.2.1.1**. This is used to connect rigidly two rods which transmit motion in the axial direction, without rotation. These joints may be subjected to tensile or compressive forces along the axes of the rods.

Examples of cotter joint connections are: connection of piston rod to the crosshead of a steam engine, valve rod and its stem etc.



4.2.1.1F- A typical cotter with a taper on one side only (Ref.[6]).

A typical cotter joint is as shown in **figure-4.2.1.2**. One of the rods has a socket end into which the other rod is inserted and the cotter is driven into a slot, made in both the socket and the rod. The cotter tapers in width (usually 1:24) on one

side only and when this is driven in, the rod is forced into the socket. However, if the taper is provided on both the edges it must be less than the sum of the friction angles for both the edges to make it self locking i.e $\alpha_1 + \alpha_2 < \phi_1 + \phi_2$ where α_1, α_2 are the angles of taper on the rod edge and socket edge of the cotter respectively and ϕ_1, ϕ_2 are the corresponding angles of friction. This also means that if taper is given on one side only then $\alpha < \phi_1 + \phi_2$ for self locking. Clearances between the cotter and slots in the rod end and socket allows the driven cotter to draw together the two parts of the joint until the socket end comes in contact with the cotter on the rod end.

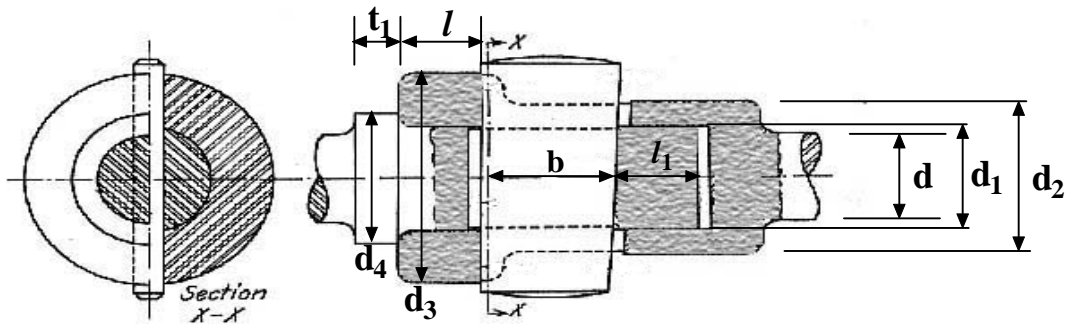

4.2.1.2F- Cross-sectional views of a typical cotter joint (Ref.[6]).

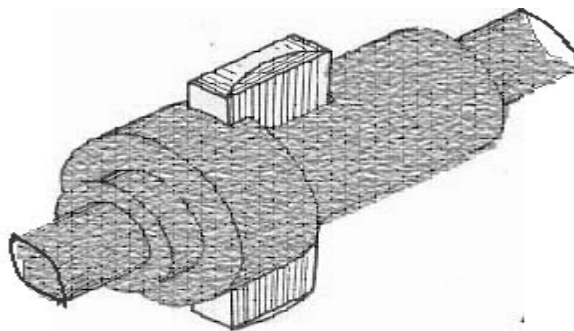

4.2.1.3F- An isometric view of a typical cotter joint (Ref.[6]).

4.2.2 Design of a cotter joint

If the allowable stresses in tension, compression and shear for the socket, rod and cotter be σ_t , σ_c and τ respectively, assuming that they are all made of the same material, we may write the following failure criteria:

1. Tension failure of rod at diameter d

$$\frac{\pi}{4} d^2 \sigma_t = P$$

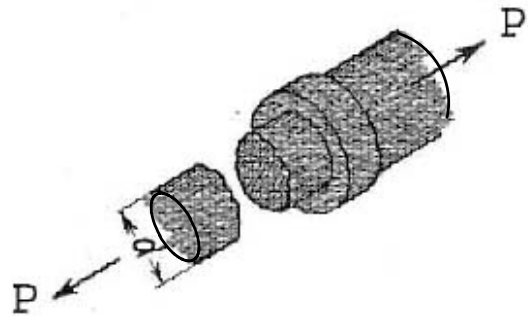

4.2.2.1F- Tension failure of the rod (Ref.[6]).

2. Tension failure of rod across slot

$$\left(\frac{\pi}{4} d_1^2 - d_1 t \right) \sigma_t = P$$

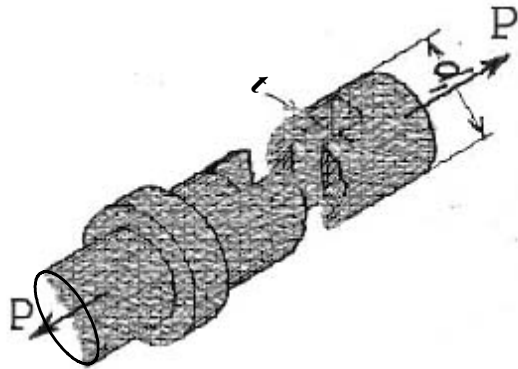

4.2.2.2F- Tension failure of rod across slot (Ref.[6]).

3. Tensile failure of socket across slot

$$\left(\frac{\pi}{4} (d_2^2 - d_1^2) - (d_2 - d_1)t \right) \sigma_t = P$$

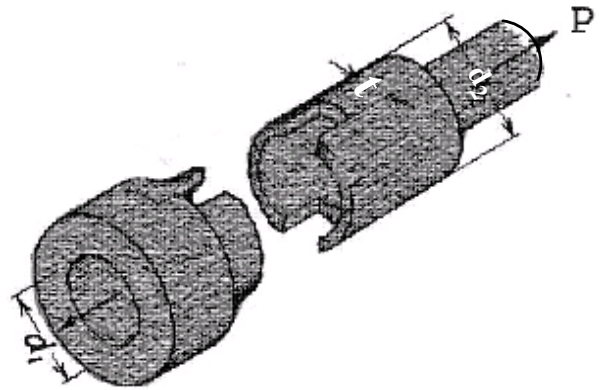

4.2.2.3F- Tensile failure of socket across slot (Ref.[6]).

4. Shear failure of cotter

$$2bt\tau = P$$

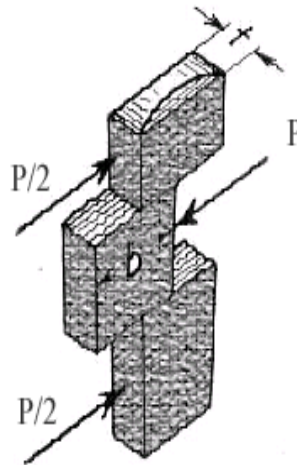

4.2.2.4F- Shear failure of cotter (Ref.[6]).

5. Shear failure of rod end

$$2l_1d_1\tau = P$$

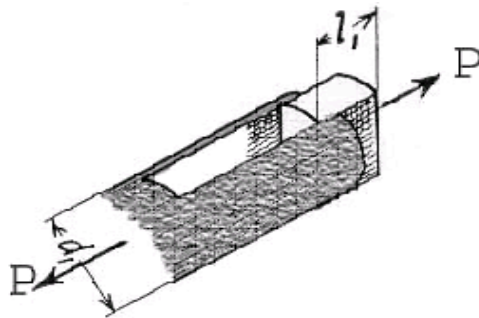

4.2.2.5F- Shear failure of rod end (Ref.[6]).

6. Shear failure of socket end

$$2l(d_3 - d_1)\tau = P$$

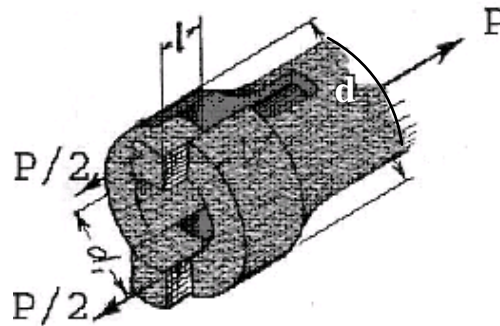

4.2.2.6F- Shear failure of socket end (Ref.[6]).

7. Crushing failure of rod or cotter

$$d_1 t \sigma_c = P$$

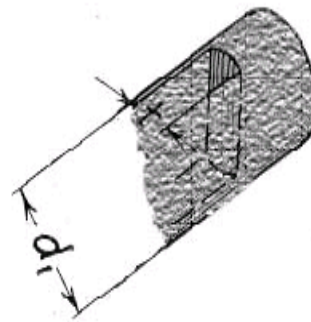

4.2.2.7F- Crushing failure of rod or cotter (Ref.[6]).

8. Crushing failure of socket or rod

$$(d_3 - d_1) t \sigma_c = P$$

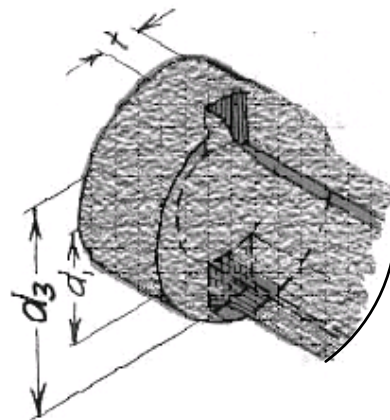

4.2.2.8F- Crushing failure of socket or rod (Ref.[6]).

9. Crushing failure of collar

$$\left(\frac{\pi}{4}(d_4^2 - d_1^2)\right)\sigma_c = P$$

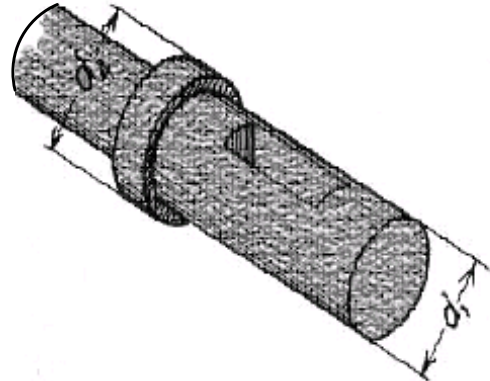

4.2.2.9F- Crushing failure of collar (Ref.[6]).

10. Shear failure of collar

$$\pi d_1 t_1 \tau = P$$

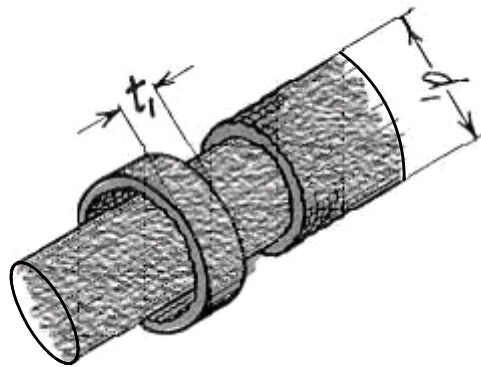

4.2.2.10F- Shear failure of collar (Ref.[6]).

Cotters may bend when driven into position. When this occurs, the bending moment cannot be correctly estimated since the pressure distribution is not known. However, if we assume a triangular pressure distribution over the rod, as shown in figure-4.2.2.11 (a), we may approximate the loading as shown in figure-4.2.2.11 (b)

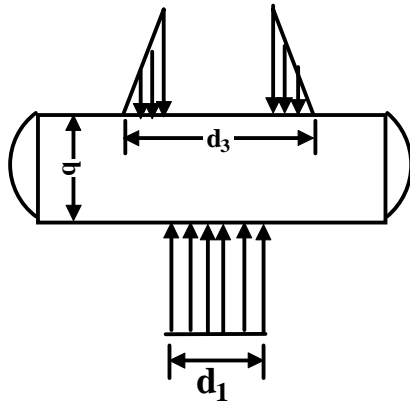

(a)

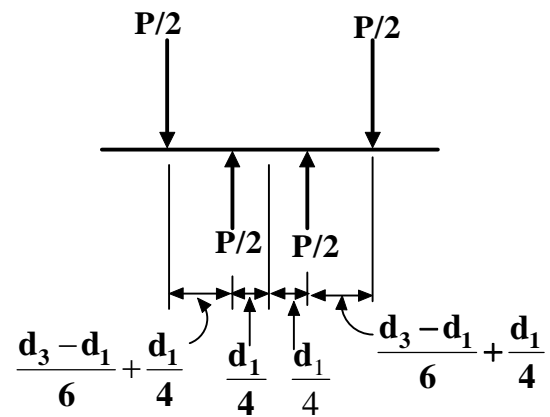

(b)

4.2.2.11F- Bending of the cotter

This gives maximum bending moment = $\frac{P}{2} \left(\frac{d_3 - d_1}{6} + \frac{d_1}{4} \right)$ and

$$\text{The bending stress, } \sigma_b = \frac{\frac{P}{2} \left(\frac{d_3 - d_1}{6} + \frac{d_1}{4} \right) \frac{b}{2}}{\frac{tb^3}{12}} = \frac{3P \left(\frac{d_3 - d_1}{6} + \frac{d_1}{4} \right)}{tb^2}$$

Tightening of cotter introduces initial stresses which are again difficult to estimate. Sometimes therefore it is necessary to use empirical proportions to design the joint. Some typical proportions are given below:

$$d_1 = 1.21.d$$

$$d_2 = 1.75.d$$

$$d_3 = 2.4 d$$

$$d_4 = 1.5.d$$

$$t = 0.31d$$

$$b = 1.6d$$

$$l = l_1 = 0.75d$$

$$t_1 = 0.45d$$

$$s = \text{clearance}$$

A design based on empirical relation may be checked using the formulae based on failure mechanisms.

4.2.3 Knuckle Joint

A knuckle joint (as shown in **figure- 4.2.3.1**) is used to connect two rods under tensile load. This joint permits angular misalignment of the rods and may take compressive load if it is guided.

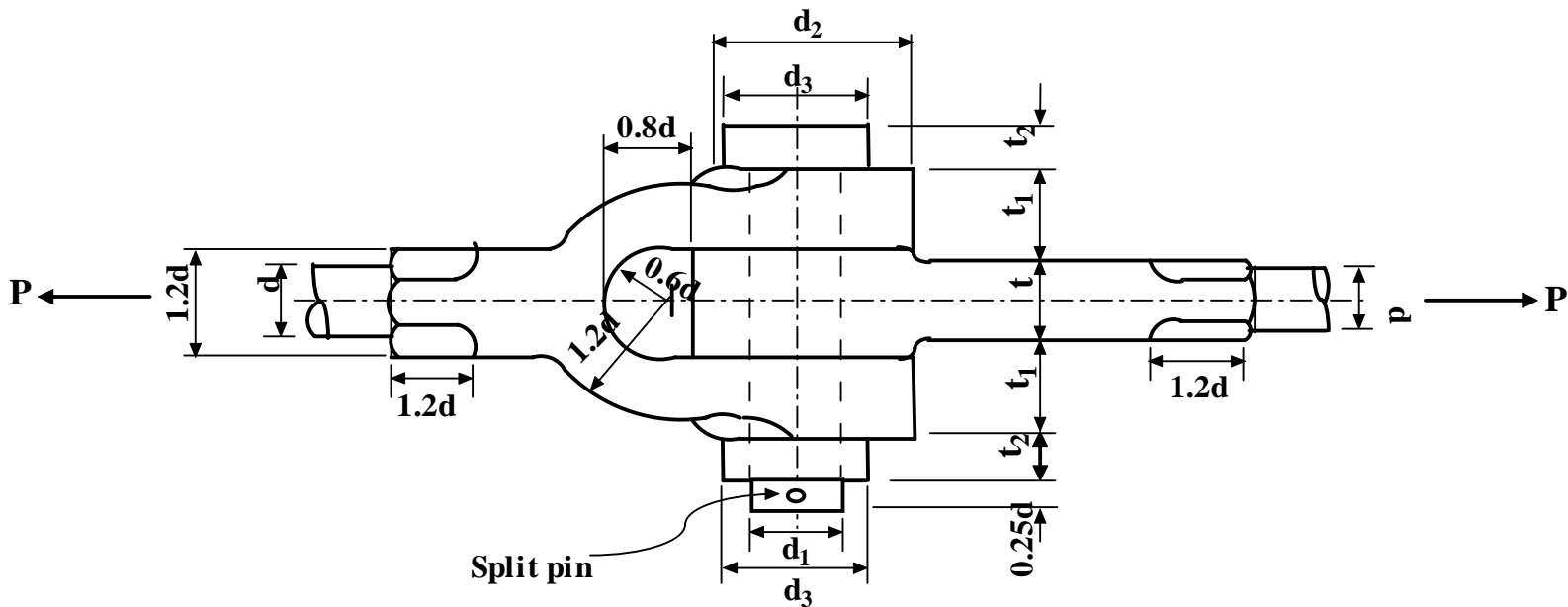

4.2.3.1F- A typical knuckle joint

These joints are used for different types of connections e.g. tie rods, tension links in bridge structure. In this, one of the rods has an eye at the rod end and the other one is forked with eyes at both the legs. A pin (knuckle pin) is inserted through the rod-end eye and fork-end eyes and is secured by a collar and a split pin.

Normally, empirical relations are available to find different dimensions of the joint and they are safe from design point of view. The proportions are given in the **figure-4.2.3.1**.

d = diameter of rod

$$d_1 = d \qquad t = 1.25d$$

$$d_2 = 2d \qquad t_1 = 0.75d$$

$$d_3 = 1.5.d \qquad t_2 = 0.5d$$

Mean diameter of the split pin = $0.25 d$

However, failures analysis may be carried out for checking. The analyses are shown below assuming the same materials for the rods and pins and the yield stresses in tension, compression and shear are given by σ_t , σ_c and τ .

1. Failure of rod in tension:

$$\frac{\pi}{4}d^2\sigma_t = P$$

2. Failure of knuckle pin in double shear:

$$2\frac{\pi}{4}d_1^2\tau = P$$

3. Failure of knuckle pin in bending (if the pin is loose in the fork)

Assuming a triangular pressure distribution on the pin, the loading on the pin is shown in figure- 4.2.3.2.

Equating the maximum bending stress to tensile or compressive yield stress we have

$$\sigma_t = \frac{16P\left(\frac{t_1}{3} + \frac{t}{4}\right)}{\pi d_1^3}$$

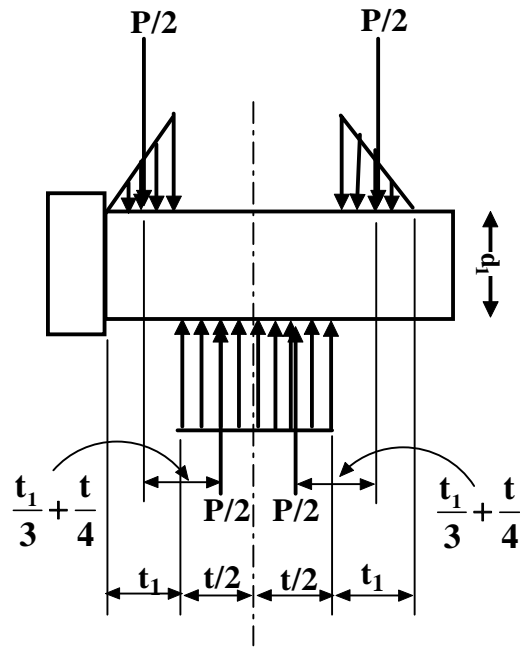

4.2.3.2F- Bending of a knuckle pin

4. Failure of rod eye in shear:

$$(d_2 - d_1) t \tau = P$$

5. Failure of rod eye in crushing:

$$d_1 t \sigma_c = P$$

6. Failure of rod eye in tension:

$$(d_2 - d_1) t \sigma_t = P$$

7. Failure of forked end in shear:

$$2(d_2 - d_1) t_1 \tau = P$$

8. Failure of forked end in tension:

$$2(d_2 - d_1) t_1 \sigma_t = P$$

9. Failure of forked end in crushing:

$$2d_1 t_1 \sigma_c = P$$

The design may be carried out using the empirical proportions and then the analytical relations may be used as checks.

For example using the 2nd equation we have $\tau = \frac{2P}{\pi d_1^2}$. We may now put value of d_1 from empirical relation and then find F.S. = $\frac{\tau_y}{\tau}$ which should be more than one.

4.2.4 Problems with Answers

Q.1: Design a typical cotter joint to transmit a load of 50 kN in tension or compression. Consider that the rod, socket and cotter are all made of a material with the following allowable stresses:

Allowable tensile stress $\sigma_y = 150$ MPa

Allowable crushing stress $\sigma_c = 110$ MPa

Allowable shear stress $\tau_y = 110$ MPa.

A.1:

Refer to figure- 4.2.1.2 and 4.2.2.1

Axial load $P = \frac{\pi}{4} d^2 \sigma_y$. On substitution this gives $d = 20$ mm. In general

standard shaft size in mm are

6 mm to 22 mm diameter	2 mm in increment
25 mm to 60 mm diameter	5 mm in increment
60 mm to 110 mm diameter	10 mm in increment
110 mm to 140 mm diameter	15 mm in increment
140 mm to 160 mm diameter	20 mm in increment
500 mm to 600 mm diameter	30 mm in increment

We therefore choose a suitable rod size to be 25 mm.

Refer to figure-4.2.2.2

For tension failure across slot $\left(\frac{\pi}{4}d^2 - d_1t\right)\sigma_y = P$. This gives $d_1t = 1.58 \times 10^{-4} \text{ m}^2$. From empirical relations we may take $t = 0.4d$ i.e. 10 mm and this gives $d_1 = 15.8 \text{ mm}$. Maintaining the proportion let $d_1 = 1.2d = 30 \text{ mm}$.

Refer to figure-4.2.2.3

The tensile failure of socket across slot $\left\{\left(\frac{\pi}{4}d_2^2 - d_1^2\right) - (d_2 - d_1)t\right\}\sigma_y = P$

This gives $d_2 = 37 \text{ mm}$. Let $d_2 = 40 \text{ mm}$

Refer to figure-4.2.2.4

For shear failure of cotter $2bt\tau = P$. On substitution this gives $b = 22.72 \text{ mm}$.

Let $b = 25 \text{ mm}$.

Refer to figure-4.2.2.5

For shear failure of rod end $2l_1d_1\tau = P$ and this gives $l_1 = 7.57 \text{ mm}$. Let $l_1 = 10 \text{ mm}$.

Refer to figure-4.2.2.6

For shear failure of socket end $2l(d_2 - d_1)\tau = P$. This gives $l = 22.72 \text{ mm}$. Let $l = 25 \text{ mm}$

Refer to figure-4.2.2.8

For crushing failure of socket or rod $(d_3 - d_1)t\sigma_c = P$. This gives $d_3 = 75.5 \text{ mm}$. Let $d_3 = 77 \text{ mm}$.

Refer to figure-4.2.2.9

For crushing failure of collar $\frac{\pi}{4}(d_4^2 - d_1^2)\sigma_c = P$. On substitution this gives $d_4 = 38.4 \text{ mm}$. Let $d_4 = 40 \text{ mm}$.

Refer to figure-4.2.2.10

For shear failure of collar $\pi d_1 t_1 \tau = P$ which gives $t_1 = 4.8$ mm. Let $t_1 = 5$ mm.

Therefore the final chosen values of dimensions are

$d = 25$ mm; $d_1 = 30$ mm; $d_2 = 40$ mm; $d_3 = 77$ mm; $d_4 = 40$ mm; $t = 10$ mm;
 $t_1 = 5$ mm; $l = 25$ mm; $l_1 = 10$ mm; $b = 27$ mm.

Q.2: Two mild steel rods are connected by a knuckle joint to transmit an axial force of 100 kN. Design the joint completely assuming the working stresses for both the pin and rod materials to be 100 MPa in tension, 65 MPa in shear and 150 MPa in crushing.

A.2:

Refer to figure- 4.2.3.1

For failure of rod in tension, $P = \frac{\pi}{4} d^2 \sigma_y$. On substituting $P = 100$ kN,

$\sigma_y = 100$ MPa we have $d = 35.6$ mm. Let us choose the rod diameter $d = 40$ mm which is the next standard size.

We may now use the empirical relations to find the necessary dimensions and then check the failure criteria.

$d_1 = 40$ mm $t = 50$ mm
 $d_2 = 80$ mm $t_1 = 30$ mm;
 $d_3 = 60$ mm $t_2 = 20$ mm;

split pin diameter = $0.25 d_1 = 10$ mm

To check the failure modes:

1. Failure of knuckle pin in shear: $P / \left(2 \cdot \frac{\pi}{4} d_1^2 \right) = \tau_y$ which gives $\tau_y = 39.8$

MPa. This is less than the yield shear stress.

2. For failure of knuckle pin in bending: $\sigma_y = \frac{16P \left(\frac{t_1}{3} + \frac{t}{4} \right)}{\pi d_1^3}$. On substitution

this gives $\sigma_y = 179$ MPa which is more than the allowable tensile yield

stress of 100 MPa. We therefore increase the knuckle pin diameter to 55 mm which gives $\sigma_y = 69$ MPa that is well within the tensile yield stress.

3. For failure of rod eye in shear: $(d_2-d_1)t\tau = P$. On substitution $d_1 = 55$ mm $\tau = 80$ MPa which exceeds the yield shear stress of 65 MPa. So d_2 should be at least 85.8 mm. Let d_2 be 90 mm.
4. For failure of rod eye in crushing: $d_1t\sigma_c = P$ which gives $\sigma_c = 36.36$ MPa that is well within the crushing strength of 150 MPa.
5. Failure of rod eye in tension: $(d_2-d_1)t\sigma_t = P$. Tensile stress developed at the rod eye is then $\sigma_t = 57.14$ MPa which is safe.
6. Failure of forked end in shear: $2(d_2-d_1)t_1\tau = P$. Thus shear stress developed in the forked end is $\tau = 47.61$ MPa which is safe.
7. Failure of forked end in tension: $2(d_2-d_1)t_1\sigma_y = P$. Tensile strength developed in the forked end is then $\sigma_y = 47.61$ MPa which is safe.
8. Failure of forked end in crushing: $2d_1t_1\sigma_c = P$ which gives the crushing stress developed in the forked end as $\sigma_c = 42$ MPa. This is well within the crushing strength of 150 MPa.

Therefore the final chosen values of dimensions are:

$d_1 = 55$ mm	$t = 50$ mm
$d_2 = 90$ mm	$t_1 = 30$ mm; and $d = 40$ mm
$d_3 = 60$ mm	$t_2 = 20$ mm;

4.2.5 Summary of this Lesson

In this lesson two well known joints viz. cotter and knuckle joints used in machinery are discussed. Their constructional detail and working principle have been described. Then the detailed design procedures of both these joints are given with suitable illustrations. Finally two examples, one on cotter joint and the other on knuckle joint have been solved.

Source:

http://nptel.ac.in/courses/Webcourse-contents/IIT%20Kharagpur/Machine%20design1/pdf/Module-4_lesson-2.pdf