

ELECTRONIC MULTIMETER

For the measurement of d.c. as well as a.c. voltage and current, resistance, an electronic multimeter is commonly used. It is also known as Voltage-Ohm Meter (VOM) or multimeter. The important salient features of YOM are as listed below.

- 1) The basic circuit of YOM includes balanced bridge d.c. amplifier.
- 2) To limit the magnitude of the input signal, RANGE switch is provided. By properly adjusting input attenuator input signal can be limited.
- 3) It also includes rectifier section which converts a.c. input signal to the d.c. voltage.
- 4) It facilitates resistance measurement with the help of internal battery and additional circuitry.
- 5) The various parameters measurement is possible by selecting required function using FUNCTION switch.
- 6) The measurement of various parameters is indicated with the help of indicating Meter.

Use of multimeter for D.C measurement:

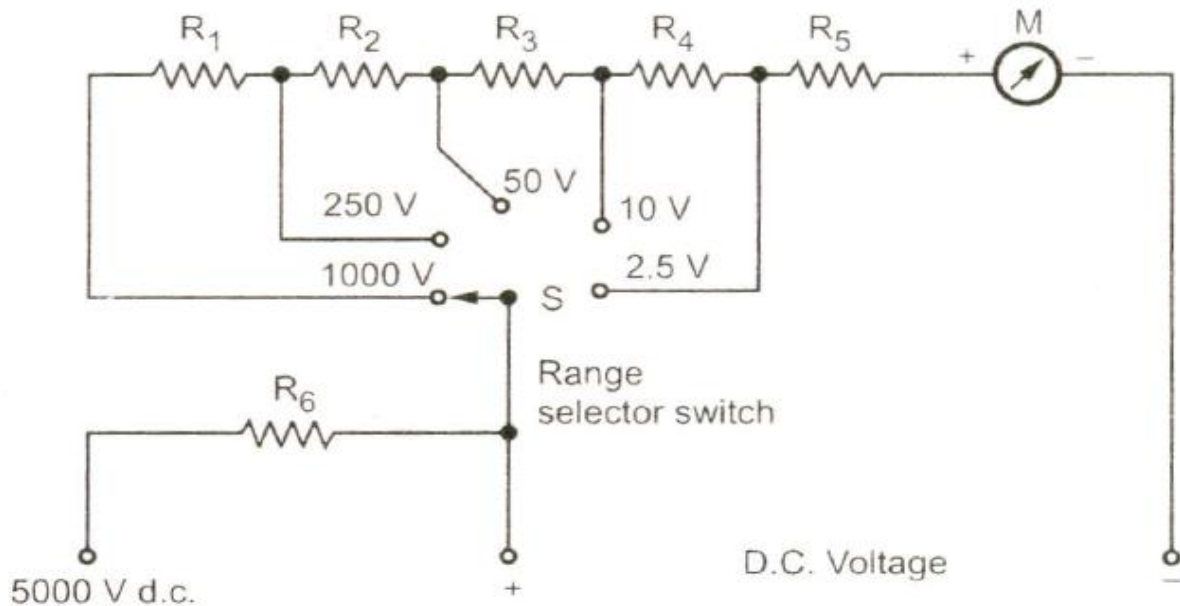

For getting different ranges of voltages, different series resistances are connected in series which can be put in the circuit with the range selector switch. We can get different ranges to measure the d.c. voltages by selecting the proper resistance in series with the basic meter.

Use of multimeter as ammeter:

To get different current ranges, different shunts are connected across the meter with the help of range selector switch. The working is same as that of PMMC ammeter

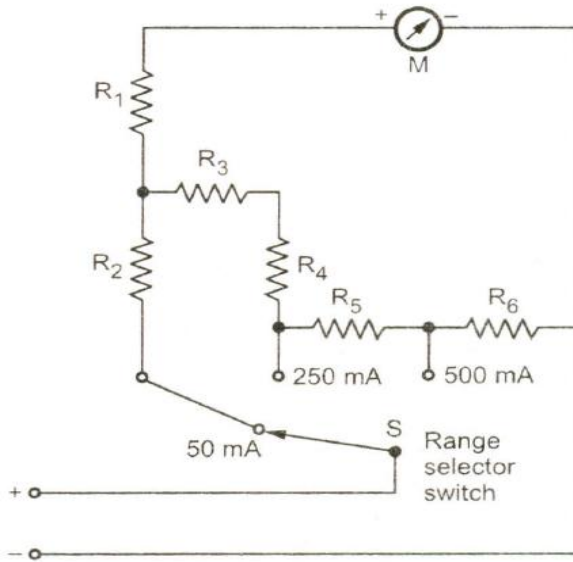

Use of multimeter for measurement of A.C voltage:

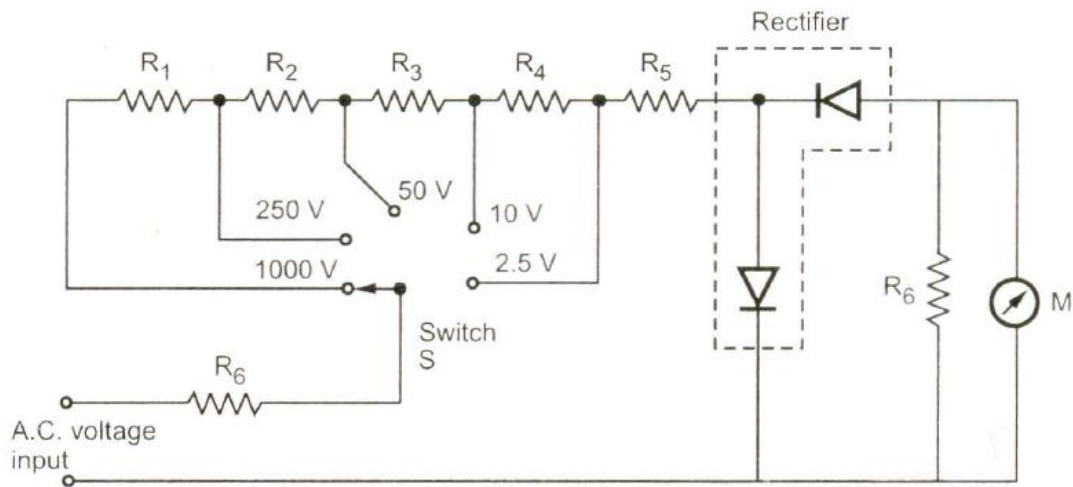

The rectifier used in the circuit rectifies a.c. voltage into d.c. voltage for measurement of a.c. voltage before current passes through the meter. The other diode is used for the protection purpose.

Use of multimeter for resistance measurement:

The Fig shows ohmmeter section of multimeter for a scale multiplication of 1. Before any measurement is made, the instrument is short circuited and "zero adjust" control is varied until the meter reads zero resistance i.e. it shows full scale current. Now the circuit takes the form of a variation of the shunt type ohmmeter. Scale multiplications of 100 and 10,000 can also be used for measuring high resistances. Voltages are applied the circuit with the help of battery.

