

ZIGBEE BASED MINE SAFETY MONITORING SYSTEM WITH GSM

RAJKUMAR BODDU, P.BALANAGU & N.SURESH BABU

Department of Electronics and Communication Engineering,
Chirala Engineering College, Chirala.

Abstract: In this work, a safe Coal Mine Monitoring system which replaces the traditional coal mine monitoring systems which tend to be wired network systems. This play an important role in coal mine safe production. With continuous enlarging of exploiting areas and extension of depth in coal mine, many laneways become monitoring blind areas, where are lots of hidden dangers. Moreover, it is inconvenient to lay cables which are expensive and consume time. In order to solve the problems, we designed a coal mine safety monitoring system based on wireless sensor network, which can improve the level of monitoring production safety and reduce accident in the coal mine. Zigbee technology provides a direction for scientists who commit to solve the safety monitoring problems of coal mine. The purpose of this study is to propose a solution suitable to mine wireless communication, safety monitoring, give a proof to the further study.

Keywords: *Zigbee, Coal Safety, GPRS.*

1. INTRODUCTION

The safe production level of coal mine is still low, especially in recent years, disasters of coal mine occur frequently, which lead to great loss of possession and life, the safety problems of coal mine has gradually become to the focus that the nation and society concern on.

The disasters of coal mine happening are due to the complexity of mine environment and the variety of work condition of coal mine, so it is very necessary to monitor mine working environment. The various environmental parameters of mine safety monitoring and controlling system, such as methane, carbon monoxide, temperature, oxygen and so on, are currently using the traditional cable transmission. Thus truly mine methane, carbon monoxide gas accumulation area mechanized mining face, such as the dead gob cable security parameters cannot be monitored, so they cannot predict the alarm. A variety of products for the current diversity of coal mine safety and underground coal mining process variability space, mine safety wireless network should be compatible with existing mine safety system with data transmission functions, has good flexibility, scalability, self-set of network capabilities. As the mine has its own special applications require a simple sensor network protocols, network easy, self-organization, self-healing ability. Zigbee is a wireless communications technology, with a short distance, safe and reliable, you can use Zigbee technology to collect the various parameters of the terminal transmitted to the sensor on the tunnel gateway, and then use a wired data transmission to the gateway on the ground central control computer, by computer analysis and comparison of the data in order to assess the security situation in the Mine. To achieve the target location underground, environmental and other parameters of the remote collection, can provide scientific basis for relief. Underground mine

environment, the complexity of the power consumption, interference immunity and so have more stringent requirements.

In [8], an agent-based wireless local positioning system with ZigBee technology is proposed, mainly for factory level applications. A cost effective ZigBee-based wireless mine supervising system with early-warning intelligence on methane, temperature, humidity in mining area is proposed in [9]. Again, another article [10] presents the development of a system integrated to a ZigBee network to measure the whole human body vibration, for the persons exposed to vibratory environment. ZigBee specification is incorporated by many manufacturers in their devices because of its low power consumption and decreasing development cost. In the work presented here, Digi make ZIGBEE24 product is used here for transmitting and receiving data wirelessly.

2. ARCHITECTURE OF THE SYSTEM

The developed system can be divided into two sections. First is a hardware circuit that will be attached with the body of the mine workers. This may be preferably fitted with the safety helmet of the workers also.

The circuit has a sensor module consisting of some MEMS based sensors that measures real-time underground parameters like temperature, humidity and gas concentration.

Gas concentration is meant for the harmful gases like methane and carbon-monoxide. A microcontroller is used with the sensors to receive the sensor outputs and to take the necessary decision.

Once temperature is more than the safety level preprogrammed at microcontroller, it decodes beep alarms through the headset speaker connected with controller as shown in Fig. 1. Again, once the measured humidity value is more than the safety level

preprogrammed at microcontroller, it decodes different type of beep alarms.

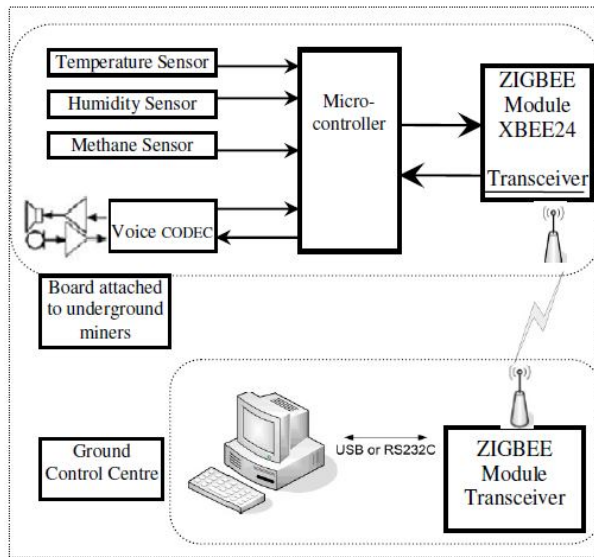

Figure 1 General Blocks in Mine Safety System

Similarly when gas concentration crosses the safety level, microcontroller decodes siren alarms. In all such cases, this will send an alarm through an urgent message and alarm sound to the ground control terminal through zigbee.

For the voice CODEC the low size, low power, CMX639 is used which is a continuously variable slope delta modulation (CVSD) digital voice communication systems. With its robust and selectable coding algorithms, 8kbps to 128kbps data/sampling rates, supported internal clock signals makes it versatile [1].

It has analog input interface with encoder that connects the microphone and microcontroller and also an analog output interface with decoder that connects speaker/headset and microcontroller. Communication through these encoding and decoding of voice and alarm signals is effectively established with the help of microcontroller.

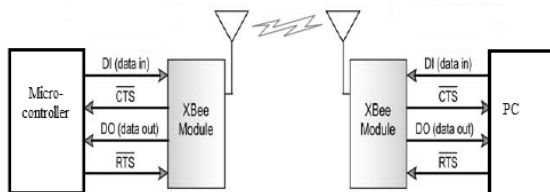

Figure 2 Connections through Zigbee module

The microcontroller data is transmitted through two separate boards i.e. ZigBee transmission module to the data collector or receiver module. The microcontroller used here is PIC 16F877A with 20MHz operating frequency. It has five I/O ports, eight A/D input channels and 368 bytes data memory. As shown in Fig. 2, the data receiving terminal of Zigbee XB_RX and data transmitting terminal XB_TX are cross connected to the microcontroller corresponding transmitter and receiver terminals TxD

and RxD respectively. No extra component like MAX 232 and MAX233 is required between these connections.

This is the advantage of PIC 16F877A .If the structure of UART (Universal Asynchronous Receiver Transmitter) system is completed, sending and receiving signal is possible using ZigBee, after installing necessary software. The RESET pin of Zigbee is used to provide an optional reset facility of user through a reset button. A transistor is used for this purpose.

The Zigbee Modules used in the interfacing boards, are engineered to meet IEEE 802.15.4 standards. It is low-cost, low-power, reliable 20 pin device that operates within the ISM 2.4 GHz frequency band. It has 30 to 100 metre data transmission capability with rate of 250,000 bps. Zigbee modules operate in five modes. When not receiving or transmitting data, the RF module is in Idle Mode. The RF module shifts into the other modes of operation under various conditions.

In transmit mode serial data is received in the DI (data in) buffer and the data is stored in the DI Buffer until it can be processed. When the DI buffer is 17 bytes away from being full, by default, the module de-asserts CTS (high) to signal to the host device to stop sending data (as shown in Fig. 2). CTS is re-asserted after the DI Buffer has 34 bytes of memory available. Smaller size data or low baud rate can be selected to avoid this state of overflow. In receive mode valid RF data is received through the antenna. When RF data is received, the data enters the DO (data out) buffer and is sent out the serial port to a host device. Once the DO buffer reaches capacity, any additional incoming RF data is lost. If RTS (hardware flow control) is enabled for flow control, data will not be sent out the DO buffer as long as RTS is de-asserted. Sleep Modes enable the RF module to enter states of low- power consumption when not in use i.e. not transmitting/receiving data for the amount of time predefined by the ST (Time before Sleep) parameter. To modify or read RF Module parameters, the module must first enter into Command Mode - a state in which incoming characters are interpreted as commands. The programming requires the installation of X-CTU software and a serial connection to a PC. The detail of the software is given in the next section. When communication occurs between two networked devices, each data packet contains a 'Source Address' and a 'Destination Address' field.

3. HARDWARE IMPLEMENTATION

ZigBee wireless sensor nodes mainly consist the sensor unit, signal conditioning circuitry, microcontroller (MCU), RF modules MC13193, timers, memory and power management module and other components shown in Fig.3.

Micro-controller is responsible for collecting environmental information (such as temperature, carbon monoxide, methane, wind speed, etc.) and do some data conversion, responsible for controlling and managing the entire nodes; RF module MC13193 is responsible for the communication between nodes by a certain protocol ; the power module provides the necessary power for the nodes separately to run the various parts.

Sensor nodes are the basis unit of wireless sensor network; node stable running ensures the reliability of the whole network. Sensor node is comprised of data acquisition module, data processing module, wireless communication module, alarm module and the power module.

Node hardware connection is shown in Fig.3. The data acquisition module is used for sensing, collecting information and converting to digital signals. According to the need for monitoring parameters of coal mine, the processor module is connected to gas sensor, pressure sensor, temperature sensor, and other kinds of sensor module, which is in charge of processing the data and coordinating the whole system.

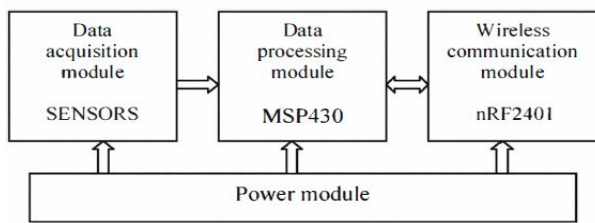

Figure 3 Wireless Sensor at Network Node

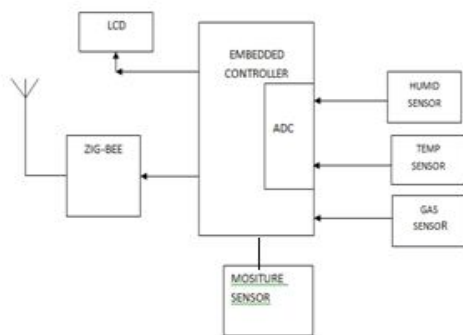

Figure 4 Block diagram for Central Monitoring System

The wireless communication module is mainly responsible for communicating with other nodes. In addition, the energy problem is the key problem, because once nodes exhaust the energy of the battery, which will drop out of the wireless sensor network, so power consumption of the wireless sensor network should be low as far as possible. Fig. 4 & Fig. 5 Shows the Block diagrams of the Present work. The

Circuit diagrams of the Present work are shown in Fig.6.

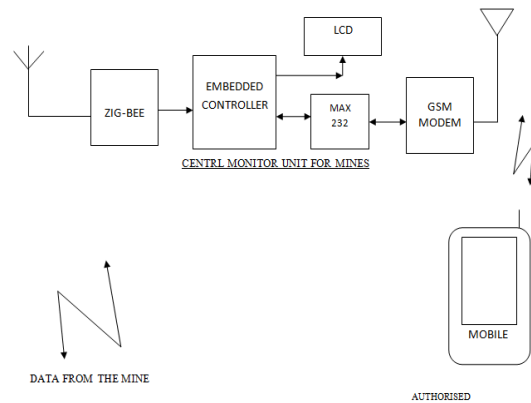

Figure 5 Block diagram for Node Equipment design

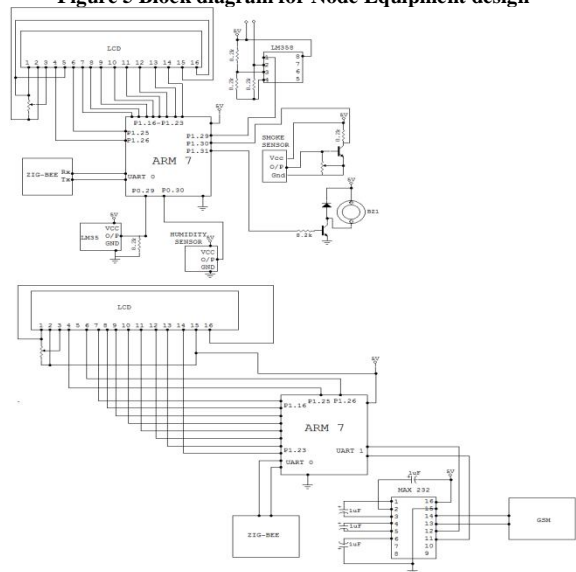

Figure 6 Circuit Implementation

4. SOFTWARE DESIGN FLOW

In software design, communication protocol layers have the energy conservation for the center. Take the communication between the sensor nodes and the network coordinator as an example to introduce the flow of communication between the ZigBee modules. Before making communication, ZigBee module need effective initialization, The initialization process between ZigBee sensor nodes and the network coordinator shown in Figure 3. During initialization, the network coordinator issues a active signaling request to connect the sensor nodes.

After the sensor nodes successfully receive and verify a data frame and MAC command frames. Return Acknowledgment frame to the sink node, the sensor node's ZigBee module is in sleep mode. After initialization, ZigBee module information processing as shown in Figure 4, the network coordinator is from the working mode to waiting for connection request signaling for the response of the sensor node, and on the regular time, the sensor nodes take the

initiative request to connect the network coordinator and report the detected security information inside the mine to the network coordinator.

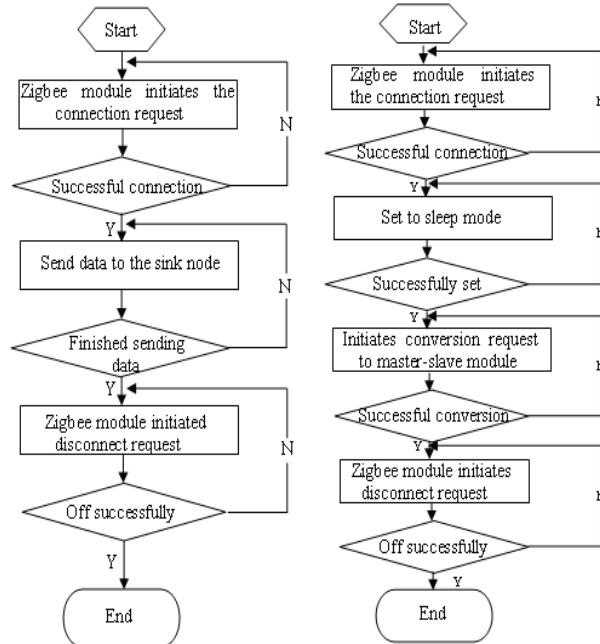

Figure 7 Design Flow for Initialization And Processing

The communication between sensor nodes and sink nodes, and exchange between sink nodes and networks coordination are similar.

Software design mainly programmed with C language combining Lab view is responsible for the collected data display, analysis and storage etc.

5. CONCLUSIONS

The Present work, coal mine safety monitoring system based on wireless sensor networks, and hardware and software design of wireless sensor network are described in detail, this system can detect concentration of the gas, temperature, humidity, wind speed and trace the location of miners in underground mine tunnels. Wireless sensor networks applied in monitoring coal mine security breaks through the traditional methods and ideas, which improves the practical ability and flexibility of monitoring system.

This system not only can monitor all kinds of parameters under the coal mine, but also can alarm automatically when environment parameters are abnormal to exceed the limitation, which help improve the level of monitoring safety production and reduce accident in the coal mine.

Therefore, the coal mine Safety Monitoring system put forward in this article quite meets the need of coal mine safety monitoring.

Traditional mine security system can be effectively replaced by the surveillance and safety system proposed in the paper.

The Example model messages to the registered mobile are shown in Fig 9 & 10. Along with

Temperature and Humidity used get the alerts regarding moistures and hazardous gases if detected at the Site of the Sensor node. This System can extended for multiple tunnels by using sensor network.

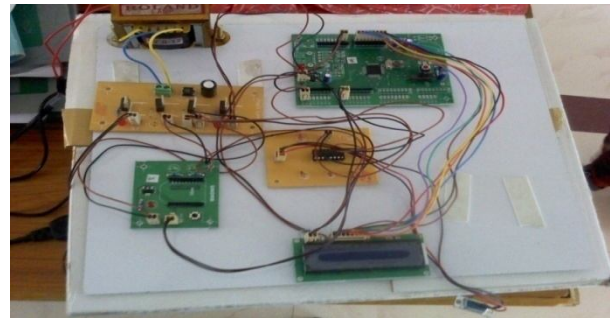

Figure 8 Implemented Mine safety Monitoring System Module

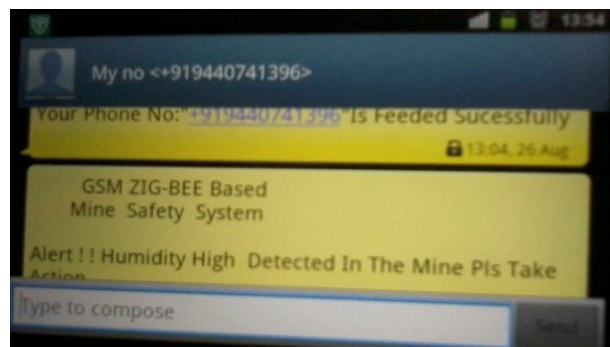

Figure 9 GSM Feedback Example Message-1

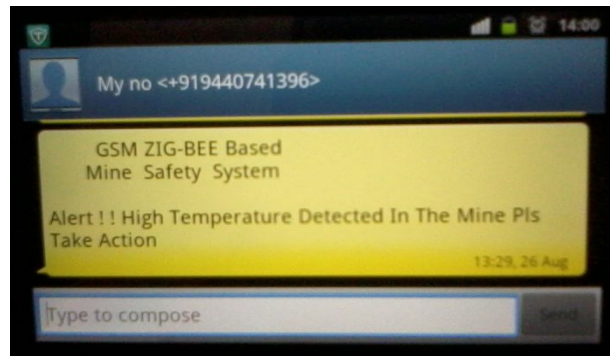

Figure 10 GSM Feedback Example Message-2

ACKNOWLEDGEMENTS

The authors would like to thank the anonymous reviewers for their comments which were very helpful in improving the quality and presentation of this paper.

REFERENCES:

- [1] Yu Hai-bin, Zeng Pengo Intelligent Wireless Sensor Network Systems [M]. Beijing: Science Press, 2006.
- [2] Zigbee Standards Organization, Zigbee Specification, Zigbee Document 053474r17, January 17, 2008.

- [3] S. Wei, L. Li-li, "Multi-parameter Monitoring System for Coal Mine based on Wireless Sensor Network Technology", Proc. international IEEE Conference on Industrial Mechatronics and Automation, pp 225-27, 2009.
- [4] N. Chaamwe, W. Liu, H. Jiang, "Seismic Monitoring in Underground Mines: A case of Mufulira Mine in Zambia Using wireless Sensor Networks for Seismic Monitoring", Proc. IEEE international Conference on Electronics and Information Engineering, vol. 1(V1), pp 310-14, 2010.
- [5] Qiao Ying-xu, Design of Wireless Sensor Networks Node Based On TinyOS Operating System. The 3th International Conference on Computer Science and Education[C] 2008.7 1201-1204
- [6] Jilin Li, "Status and Development Trend of Coal Mine Safety Monitoring System", Journal, Coal Technology, Harbin, 2008(11), pp. 4- 5.
- [7] D. Koenig, M. S. Chiamonte, A. Balbinot, "Wireless Network for Measurement of Whole-Body Vibration", J. Sensors, vol. 8, pp. 3067-81, 2008
- [8] D. Egan, "The Emergence of ZigBee in building automation and industrial controls", J. IEE Computing & Control Engineering, vol. 16(2), pp. 14-19, 2005.
- [9] Hu Huo. Kjl3 Mine Monitoring System Software Design and Implementation. Computer Development & Applications, 2008,14, (5).
- [10] Zhang Hong, Zhang Jie. Wireless sensor network technology based on coal mine safety monitoring system [J]. Microcontroller and Embedded Systems, 2009

AUTHORS PROFILE:



Rajkumar Boddu is pursuing M.Tech in VLSI &ES at Chirala Engineering College, Chirala.



P. Balanagu, M.Tech in Micro electronics from VTU, Belgam Working as Assoc. prof in ECE Dept. CEC, Chirala. He has 9 years of teaching Experience.



Prof. N. Suresh Babu is Vice- Principal & HOD of ECE Dept in CEC, Chirala. He got his M.Tech in Microwave Engineering from Birla Institute of technology, Ranchi. He has 13 years of teaching Experience and 2 Years of Industrial Experience in various organisations .

