

TYPES OF ADC

Direct-conversion ADC/Flash type ADC:

This process is extremely fast with a sampling rate of up to 1 GHz. The resolution is however, limited because of the large number of comparators and reference voltages required. The input signal is fed simultaneously to all comparators. A priority encoder then generates a digital output that corresponds with the highest activated comparator.

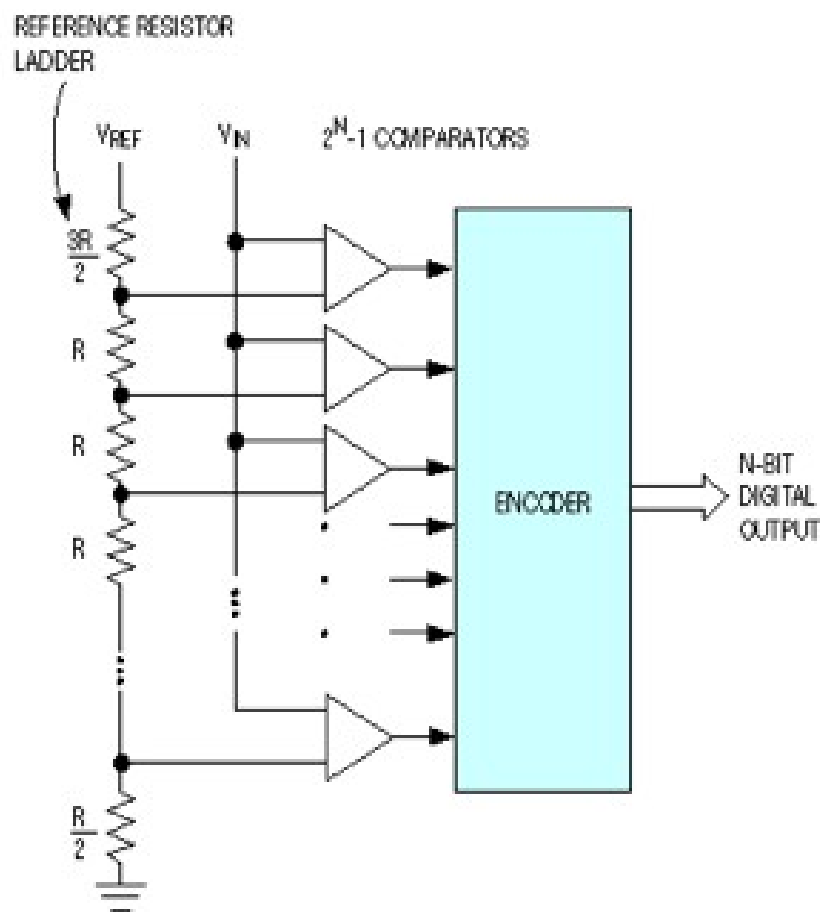

Successive-approximation ADCs

Successive-approximation ADC is a conversion technique based on a successive-approximation register (SAR). This is also called bit-weighting conversion that employs a comparator to weigh the applied input voltage against the output of an N-bit digital-to-analog converter (DAC). The final result is obtained as a sum of N weighting steps, in which each step is a single-bit conversion using the DAC output as a reference. SAR converters sample at rates up to 1Mbps, requires a low supply current, and the cheapest in terms of production cost.

A successive-approximation ADC uses a comparator to reject ranges of voltages, eventually settling on a final voltage range. Successive approximation works by constantly comparing the input voltage to the output of an internal digital to analog converter (DAC, fed by the current value of the approximation) until the best approximation is achieved. At each step in this process, a binary value of the approximation is stored in a successive approximation register (SAR). The SAR uses a reference voltage (which is the largest signal the ADC is to convert) for comparisons. For example if the input voltage is 60 V and the reference voltage is 100 V, in the 1st clock cycle, 60 V is compared to 50 V (the reference, divided by two. This is the voltage at the output of the internal DAC when the input is a '1' followed by zeros), and the voltage from the comparator is positive (or '1') (because 60 V is greater than 50 V). At this point the first binary digit (MSB) is set to a '1'. In the 2nd clock cycle the input voltage is compared to 75 V (being halfway between 100 and 50 V: This is the output of the internal DAC when its input is '11' followed by zeros) because 60 V is less than 75 V, the comparator output is now negative (or '0'). The second binary digit is therefore set to a '0'. In the 3rd clock cycle, the input voltage is compared with 62.5 V (halfway between 50 V and 75 V: This is the output of the internal DAC when its input is '101' followed by zeros). The output of the comparator is negative or '0' (because 60 V is less than 62.5 V) so the third binary digit is set to a 0. The fourth clock cycle similarly results in the fourth digit being a '1' (60 V is greater than 56.25 V, the DAC output for '1001' followed by zeros). The result of this would be in the binary form 1001. This is also called *bit-weighting conversion*, and is similar to a binary. The analogue value is rounded to the nearest binary value below, meaning this converter type is mid-rise (see above). Because the approximations are successive (not simultaneous), the conversion takes one clock-cycle for each bit of resolution desired. The clock frequency must be equal to the sampling frequency multiplied by the number of bits of resolution desired. For example, to sample audio at 44.1 kHz with 32 bit resolution, a clock frequency of over 1.4 MHz

would be required. ADCs of this type have good resolutions and quite wide ranges. They are more complex than some other designs.

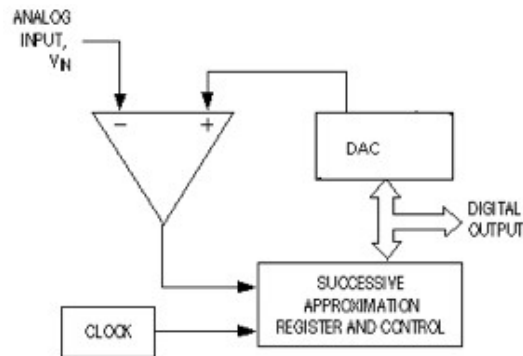

Integrating ADCs

In an integrating ADC, a current, proportional to the input voltage, charges a capacitor for a fixed time interval T charge. At the end of this interval, the device resets its counter and applies an opposite-polarity negative reference voltage to the integrator input. Because of this, the capacitor is discharged by a constant current until the integrator output voltage zero again. The T discharge interval is proportional to the input voltage level and the resultant final count provides the digital output, corresponding to the input signal. This type of ADCs is extremely slow devices with low input bandwidths. Their advantage, however, is their ability to reject high-frequency noise and AC line noise such as 50Hz or 60Hz. This makes them useful in noisy industrial environments and typical application is in multi-meters.

An integrating ADC (also dual-slope or multi-slope ADC) applies the unknown input voltage to the input of an integrator and allows the voltage to ramp for a fixed time period (the run-up period). Then a known reference voltage of opposite polarity is applied to the integrator and is allowed to ramp until the integrator output returns to zero (the run-down period). The input voltage is computed as a function of the reference voltage, the constant run-up time period, and the measured run-down time period. The run-down time measurement is usually made in units of the converter's clock, so longer integration times allow for higher resolutions. Likewise, the speed of the converter can be improved by sacrificing resolution. Converters of this type (or variations on the concept) are used in most digital voltmeters for their linearity and flexibility.

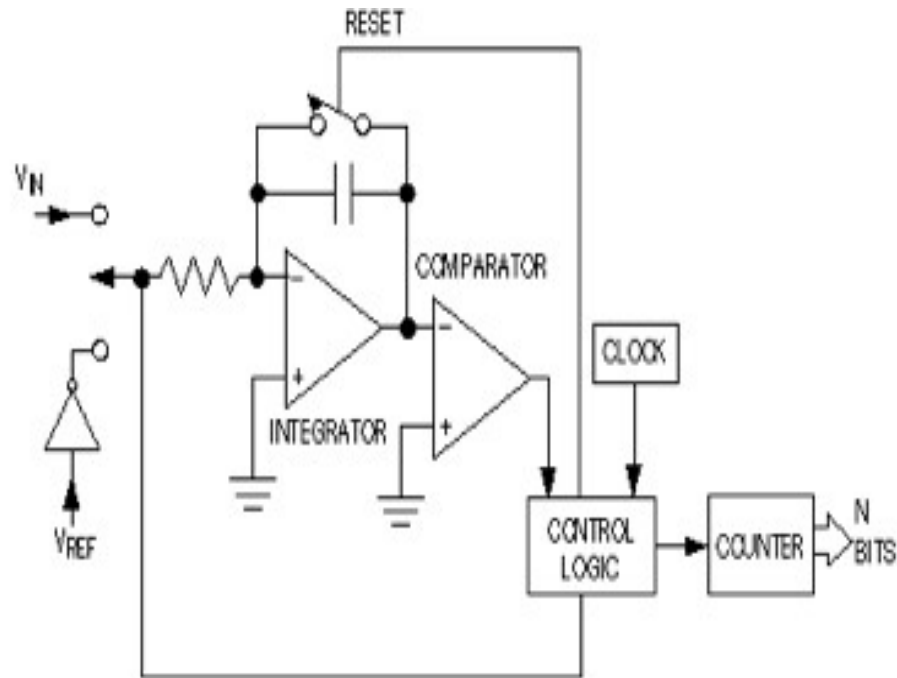

Sigma-delta ADCs/ Over sampling Converters:

It consists of 2 main parts - modulator and digital filter. The modulator includes an integrator and a comparator with a feedback loop that contains a 1-bit DAC. The modulator oversamples the input signal, converting it to a serial bit stream with a frequency much higher than the required sampling rate. This is then transformed by the output filter to a sequence of parallel digital words at the sampling rate. The characteristics of sigma-delta converters are high resolution, high accuracy, low noise and low cost. Typical applications are for speech and audio.

A **Sigma-Delta ADC** (also known as a Delta-Sigma ADC) oversamples the desired signal by a large factor and filters the desired signal band. Generally a smaller number of bits than required are converted using a Flash ADC after the Filter. The resulting signal, along with the error generated by the discrete levels of the Flash, is fed back and subtracted from the input to the filter. This negative feedback has the effect of noise shaping the error due to the Flash so that it does not appear in the desired signal frequencies. A digital filter (decimation filter) follows the ADC which reduces the sampling rate, filters off unwanted noise signal and increases the resolution of the output. (sigma-delta modulation, also called delta-sigma modulation)