

System Concept for Low Analog Complexity and High-IF Superposition Heterodyne Receivers

Marko Mailand and Hans-Joachim Jentschel

Abstract—For today’s and future wireless communications applications, more and more data traffic has to be transmitted with growing speed and quality demands. The analog front-end of any mobile device has to cope with very hard specifications regardless which transmission standard has to be supported. State-of-the-art analog front-end implementations are reaching the limit of technical feasibility. For that reason, alternative front-end architectures could support a continuing development of mobile communications e.g., six-port-based front-ends [1], [2].

In this article we propose an analog front-end with high intermediate frequency and which utilizes additive mixing instead of multiplicative mixing. The system architecture is presented and several spurious effects as well as their influence on the system dimensioning are discussed. Furthermore, several issues concerning the technical feasibility are provided and some simulation results are discussed which show the principle functionality of the proposed superposition heterodyne receiver.

Keywords—receivers, analog front-end, heterodyning, self-mixing.

I. INTRODUCTION

FUTURE mobile communications devices will have to comprise wide band and reconfiguration capability. One of the most serious bottlenecks is the integration of appropriate analog front-ends for the realization of mobile terminals which guarantee sufficient transmission quality.

Besides low intermediate frequency (IF) [3] or direct conversion techniques [4], wide-band-IF or high-IF concepts are still of interest [5]. For the latter ones, the aim is to keep the IF comparably high in order to diminish those dirty RF effects which appear at lower frequencies, e.g. DC-offsets, flicker noise influences, etc. and to enable image-signal suppression at the analog side. Additionally, with the selection of a high IF, the interest is kept on realizing analog-to-digital converters (ADC) with higher sampling rates, whose development could possibly lead to real software defined radios in future. However, the issues of integration, circuitry and system complexity as well as lowest possible power consumption have to be considered for any type of front-end.

An upcoming technology for receiver front-ends is the so called six-port receiver [1], [2], [6]-[8]. Usually, direct conversion is realized. Nevertheless, Jentschel [1] showed that the six-port is also suitable for intermediate frequency conversion concepts.

We present a six-port based superposition heterodyne receiver with low analog complexity in the following sections.

Dipl.-Ing. Marko Mailand and Prof.Dr.-Ing.habil. Hans-Joachim Jentschel are with the Institute of Traffic Communications Engineering, "Friedrich List" Faculty of Transport and Traffic Sciences of the Dresden University of Technology, 01069 Dresden, Germany. Email: {mailand, jentschel}@vini.vkw.tu-dresden.de, Telephone: +49 351 463 36753.

Important issues of the signal transmission within the receiver are investigated, such as spectral composition of the down converted signals, etc. Moreover, it will be derived for which reason higher IF reception is preferable for these systems. Further, aspects for the realization for different communication standards by different circuitry technologies are given. The general functionality will be verified by simulation results.

II. THE SUPERPOSITION HETERODYNE RECEIVER ARCHITECTURE

With the implementation of so-called six-port receiver front-ends, it is possible to enable the integration of wide band and multi-protocol devices [2], [7]. Additive mixing instead of conventional multiplicative mixing is realized for down conversion if the six-port technology was utilized.

Major advantages of six-port front-ends are that no mixers are needed and that the wide band capability is more easily achievable. Exemplarily in [7], bandwidths of up to 20 MHz with a RF-frequency region of (2-5)GHz are reported. Furthermore, such front-ends are significantly more robust against deviations of the RF-power level.

In [1], the ability of the six-port was systematically derived to perform a heterodyne or IF reception, i.e. the superposition heterodyne reception.

In order to reduce circuitry complexity of large and power consumptive devices, a five-port front-end was suggested for direct down conversion or zero-IF [8]. Within the proposed superposition heterodyne receiver (Fig. 1), the desired RF-signal¹, i.e. $s_{RF}(t) = Re\{\underline{s}_{RF}(t)\}$ with $\underline{s}_{RF}(t) = \underline{s}(t) \cdot \exp(j2\pi f_{RF}t)$ is generally superimposed by the complex scaled local oscillator (LO) signal $s_{LO}(t) = Re\{G_i \exp(-j(2\pi f_{LO}t + \varphi_i))\}$. The desired signal shall be denoted as $\underline{s}(t) = I(t) + j \cdot Q(t)$, whereas I is the in-phase and Q the quadrature-phase component. One single channel $s_{RF}(t)$ shall have the bandwidth BW_{Ch} . The intermediate frequency is $f_{IF} = f_{RF} - f_{LO}$. The RF-band filter with the bandwidth BW_{RF} is usually realized as external crystal or SAW component. The band-pass filter (BPF) at IF has the bandwidth BW_{IF} and suppresses all higher RF terms as well as DC-offsets. Usually, it realizes a partial channel filtering [5]. Within heterodyne receivers, the final channel selection happens in the digital domain (not explicitly shown in Fig. 1).

¹In this article, we denote complex signals with $\underline{x}(t)$, real signals with $x(t)$, spectral signal representations with $X(f)$ and general matrices with \mathbf{X} . For digitized signals, the correspondence $t = kT$ is used and hence continuous time signals $x(t)$ turn into their discrete time equivalents $x(k)$.

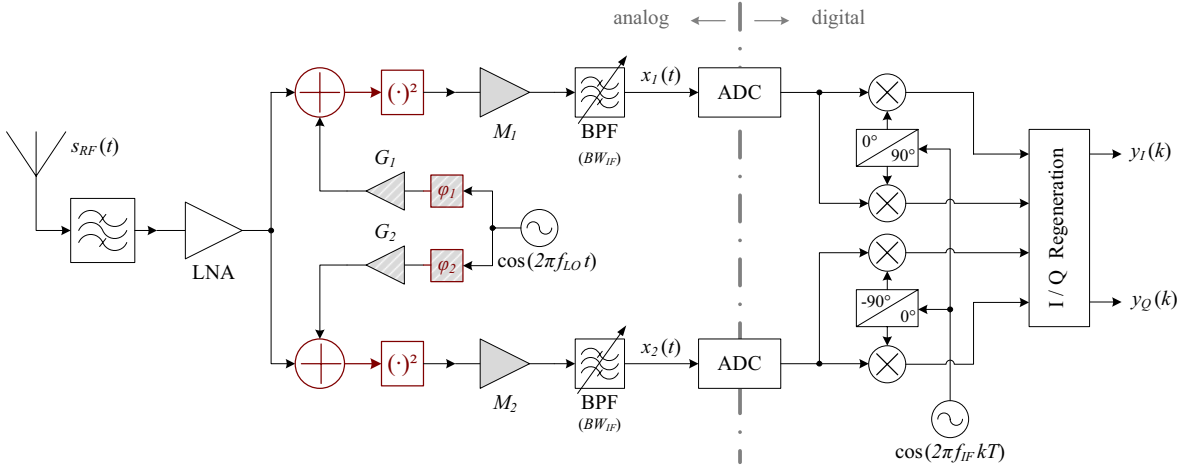

Fig. 1. Architecture of the Superposition Heterodyne Receiver with low analog complexity.

With respect to the signal transmission of the receiver, certain circuitry insufficiencies must be considered. Therefore, we included the models for phase, amplitude and path mismatches in the system architecture. It is to underline that a generally arbitrary phase difference between φ_1 and φ_2 not equaling zero is strongly required in order to have a nonsingular transmission matrix of the front-end, i.e. to be able to demodulate the IQ-signals. The best choice for $|\varphi_1 - \varphi_2|$ was exactly 90° which can not be guaranteed by integrated analog circuit implementation technologies.

For the given front-end architecture, the signal of the i -th path ($i \in \{1, 2\}$) after the square-law devices but before the BPF is:

$$\tilde{x}_i(t) = M_i \left(s_{RF}(t) + G_i \cos(2\pi f_{LO} t + \varphi_i) \right)^2. \quad (1)$$

After the BPF at IF, the output signal of the front-end can be written as:

$$x_i(t) = G_i M_i \left(I(t) \cos(2\pi f_{IF} t + \varphi_i) - Q(t) \sin(2\pi f_{IF} t + \varphi_i) \right) + \underbrace{\frac{1}{2} M_i \cdot \text{BPF} \{ I(t)^2 + Q(t)^2 \}}_{\text{remaining portions of unwanted rectified wave}}. \quad (2)$$

Hence, the digitized signal will comprise a mixture of the desired signal as well as a spurious interferer, i.e. the remaining portions of the rectified wave. Depending also on the transmission standard, the rectified wave can frustrate the reception at all.

Therefore, in state-of-the-art implementations of additive mixing or superposition receiver concepts, analog/digital compensation methods are realized in order to suppress the rectified wave. Unfortunately, additional analog circuitry as well as digital signal processing for calibration procedures are required for that purpose [1],[6]-[8].

We propose to select the IF depending on spectral width of the possible rectified waves in order to avoid such compensation methods.

III. RECTIFIED WAVE AND SELECTION OF IF

The most crucial signal component within a superposition receiver is the so-called rectified wave. Neglecting the static DC-offset, it can be interpreted as second order RF-self-mixing product (RFS2). Preferably, the RFS2 has to be attenuated or even completely compensated before the analog-to-digital conversion (ADC) to reduce the dynamic range requirements for the ADC [9]. Furthermore, there are a lot of compensation methods utilizing more than two analog IF or baseband paths to enable digital compensation of the RFS2.

If we analyze the spectral composition of the rectified wave or the RFS2, respectively, it will crop up that the total power of the RFS2 corresponds to the total power of the remaining channels after the RF-band-filter at the antenna. We consider to have an RF-signal comprising of N separate, modulated channels:

$$s_{RF}(t) = \sum_{n=1}^N \text{Re} \{ \underline{s}_n(t) \cdot \exp(j 2\pi f_{n,RF} t) \}, \quad (3)$$

which cover the whole filtered RF-band of the width BW_{RF} . Than we observe:

- a rectified wave of the spectral width $2 \cdot BW_{RF}$ around $f = 0$ including a static DC-offset which originates systematically from the squaring of the LO-signal, whereas
- the RFS2 has the power (according to remaining rectified wave in (2))

$$P_{RFS2} = \sum_{n=1}^N P_n \propto \int s_{RF}(t)^2 dt. \quad (4)$$

Generally speaking, the superposition reception realizes the wanted frequency conversion but also a power detection of the complete filtered RF-band, which can frustrate a further processing of the desired signals. Hence, the rectified wave could lead to a signal composition which is not processable by the ADC. In presence of strong in-band interferers, a weak desired signal located at zero- or low-IF could not be digitized with sufficient resolution by utilizing integrated ADCs with

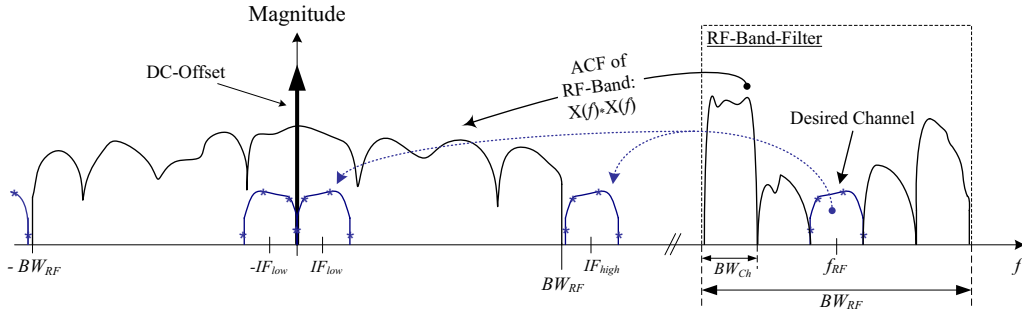

Fig. 2. Spectral composition of the IF-converted desired signal and the rectified wave which is generated by the spectral autocorrelation (ACF) of the RF-signal in frequency domain.

TABLE I
MINIMUM IF FOR DIFFERENT STANDARDS (MOBILE STATION)

Standard	BW_{RF} [MHz]	BW_{Ch} [MHz]	f_{Cs} [MHz]	Minimum f_{IF} [MHz]
GSM 900	25	0.2	0.2	25.1
DCS 1800	75	0.2	0.2	75.1
PCS 1900	60	0.2	0.2	60.1
UTRA FDD	60	3.84	5	62.5

their respective dynamic range. The spectral interrelationship of the incoming RF-band, the rectified wave and two possibilities for the intermediate frequency (low-IF... IF_{low} and high-IF... IF_{high}) are shown qualitatively in Fig. 2.

Although the power detection within the rectified wave is a serious dirty RF issue for such receivers, the spectral width of the RFS2 provides a solution to overcome this systematical impairment as well as to reduce analog/digital effort for compensation of the RFS2. Since a squaring is realized in time domain, the signals are convolved in frequency domain. Therefore, the RFS2 can be interpreted as autocorrelation function (ACF) of the filtered RF-band in frequency domain, i.e. a spectral convolution. Hence, it covers twice the bandwidth of the RF-band, i.e. $BW_{RFS2} = 2 \cdot BW_{RF}$. The respective maximum bandwidth BW_{RF} is usually determined by the communications standard being processed and therefore by the utilized RF-Filter.

No additional compensation will be required to enable sufficient signal qualities at the same time, if the IF is selected apart from the maximum frequency limit of the RFS2 followed by an appropriate IF-BPF. If we assume to have an IF-BPF which realizes a complete channel selection ($BW_{IF} = BW_{Ch}$), the minimum intermediate frequency could be determined for the respective communications standard. Table I presents several examples, whereas the minimum IF, f_{IF} is:

$$f_{IF} = BW_{RF} + \frac{1}{2} f_{Cs}, \quad (5)$$

with the carrier spacing f_{Cs} .

IV. IQ-IMBALANCE

Without the loss of general validity, we assume the first LO-signal path not to comprise phase and amplitude impairments,

i.e. $G_1 = 1$ and $\varphi_1 = 0$. Furthermore, in the following, we also consider only a relative path mismatch, such that the second path comprehends the normalized mismatch, i.e. $M_1 = 1$ and $M'_2 = M_2/M_1$. Therefore, the second path (the lower one in Fig. 1) causes the relative IQ-imbalance with respect to the first LO-path, whereas we define $\varphi_2 = \varphi$ and $G_2 \cdot M'_2 = G$. According to [10], we can denote the complex-valued LO-signal as:

$$\underline{s}_{LO}(t) = K_1 \exp(-j2\pi f_{LO}t) + K_2 \exp(j2\pi f_{LO}t) \quad (6)$$

with $K_{1,2} = 0.5 \cdot (1 \pm G \exp(\mp j\varphi))$.

Now, we consider the received RF-signal to carry two channels such that:

$$\underline{s}_{RF}(t) = \underline{z}(t) \exp(j2\pi f_{LO}t) + \underline{z}^*(t) \exp(-j2\pi f_{LO}t) \quad (7)$$

$$\underline{z}(t) = \underline{s}(t) \exp(j2\pi f_{IF}t) + \underline{i}(t) \exp(-j2\pi f_{IF}t)$$

with the desired signal $\underline{s}(t)$ and the (potential) image signal $\underline{i}(t)$. The operation $(\times)^*$ denotes complex conjugation. The intermediate frequency (IF) is situated apart from the spectral region which is covered by the rectified wave (at an appropriate IF_{high} like in Fig. 2). Hence, there will be no nonlinear influence of that kind to be considered.

With this model, the signal at the IF results in:

$$\underline{x}_{IF}(t) = BPF\{\underline{z}_{IF}\} = BPF\{\underline{s}_{RF}(t) \underline{s}_{LO}(t)\} \quad (8)$$

$$= K_1 \underline{z}(t) + K_2 \underline{z}^*(t).$$

In digital domain, the IF-signal is down-converted perfectly to baseband. Thus, we obtain finally four real valued or two complex valued observations ($d(k)$, $v(k)$) for the desired signal being somehow mixed with the image signal due to IQ-imbalance:

$$\{d(k), v(k)\} = LPF\{\underline{x}_{IF}(k) \cdot \exp(\mp j2\pi f_{IF}kT)\}, \quad (9)$$

whereas $LPF\{\times\}$ realizes the suppression of higher frequency terms by low-pass filtering. The rewriting of the baseband observations in a simple matrix notation leads to

$$\mathbf{r} = \begin{bmatrix} d(k) \\ v^*(k) \end{bmatrix} = \begin{bmatrix} K_1 & K_2 \\ K_2^* & K_1^* \end{bmatrix} \begin{bmatrix} \underline{s}(k) \\ \underline{i}^*(k) \end{bmatrix} = \mathbf{K} \mathbf{s}. \quad (10)$$

With respect to Fig. 1, the signal composition of \mathbf{r} in (10) is the input for the I/Q regeneration block (being implemented e.g., on a DSP).

Obviously, there will be two complex observations which consist of systematically complex-superimposed portions of

the desired signal $\underline{s}(k)$ and the image signal $\underline{i}(t)$. The quality of the desired signal would be insufficient in case of strong amplitude and phase imbalance.

For that reason, it is required to compensate for the IQ-imbalance. The straight forward approach is to measure various G and φ by test-tone calibration procedures after the production of the respective receiver front-end. During the reception, the *I/Q regeneration* is simply achieved by multiplying \mathbf{r} with the respective inverse of the mixing matrix \mathbf{K}^{-1} , whose values will have been obtained by the measurements. Another possibility is to include tuneable analog components with which reasonable image rejection can be realized [11].

More sophisticated methods utilize classical and unsupervised adaptive filters as well as blind prediction and blind source separation algorithms [10], [12].

However, as soon as a separation matrix $\mathbf{B} \approx \mathbf{K}^{-1}$ is obtained, the corrected IQ-components will be obtained by

$$\mathbf{y} = \begin{bmatrix} y_I(k) \\ y_Q(k) \end{bmatrix} = \text{SelWC}\left\{ \underbrace{\mathbf{B} \mathbf{K} \mathbf{s}}_{\mathbf{r}} \right\}. \quad (11)$$

$\text{SelWC}\{\times\}$ is the operator representation of the selection of the desired channel out of the *I/Q-regeneration* outputs.

V. REALIZATION ASPECTS

With the proposed superposition heterodyne receiver architecture (Fig. 1), wideband capability can be realized while less analog circuitry is required for frequency conversion. The following issues of circuitry implementation refer to the intended use of the front-end within wideband and multi-protocol mobile terminals.

The simple summing elements are realized either as a node for current technologies or as superposition of two voltage signals within one mesh-path. The square-law devices (also called *power detectors* (PD) within six-port-technology-based implementations) ought to comprehend only very low higher even-order nonlinearities. The most simple implementation of PDs are appropriate diodes [6]. On the one hand, we obtain realizations which cover only very small chip area and which do not consume valuable power while we utilize diodes. On the other hand, a diode realization will cause comparably strong higher order nonlinearities. Besides the anyway expected rectified wave, all even-order nonlinearities (NL) beyond $(\times)^2$ will cause additional distortions of spectral width being wider than the fundamental rectified wave. In [13], the influence of higher order NL within direct conversion superposition receivers was analytically derived. However, some results out of that analysis can be transferred to the proposed superposition heterodyne receiver, [13]:

- only NL of even order contribute to 'baseband'-located signals (desired signal portions as well as unwanted),
- the influence of RFS2 can be reduced by utilizing simple rectified wave attenuation like suggested in [8],
- the second order RF-self-mixing products due to a k -th-order nonlinearity are

$$x_k^{RFS}(t) = \binom{k}{\frac{k}{2}} \left(\underline{x}(t) \underline{x}^*(t) \right)^{\frac{k}{2}} = \binom{k}{\frac{k}{2}} |\underline{x}(t)|^k \quad (12)$$

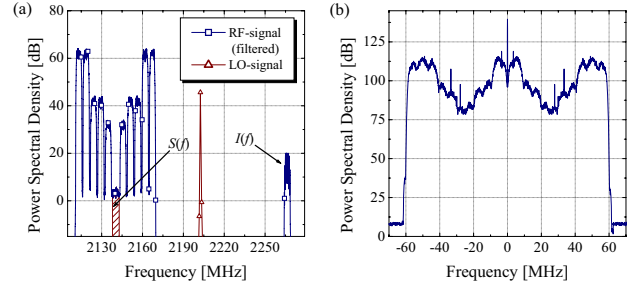

Fig. 3. Power spectral density of (a) the complete received RF-band, the image signal $I(f)$ as well as the LO-signal at 62.5MHz offset apart from the desired channel $S(f)$ and (b) the respective rectified wave.

- any NL k generates also some portions of the desired IQ-signals

$$\underline{x}_k^{IQ} = k G^{k-1} \binom{k-1}{\frac{k}{2}} \cdot \left(\underline{s}(t) \exp(j(2\pi f_{IF} - \varphi)) + \underline{s}^*(t) \exp(j(-2\pi f_{IF} + \varphi)) \right) \quad (13)$$

- and simple FET circuits can already guarantee sufficient 'square-law-quality', i.e. only marginal distortions due to higher order NL.

Moreover, a band-pass filter at an high IF with sufficient selectivity will be required. This is a very hard requirement for contemporary IC-technologies. In combination with the BPF, an analog-to-digital converter will be indispensable which is able to digitize the IF-signals with sufficient quality at the high intermediate frequencies.

With respect to the relative phase φ of the LO-paths, it was advantageous, if 90° could be realized. In such a case, no image signal would be superimposed to the desired signal. However, in practical implementations of analog front-ends, phase shifts of exactly 90° are not realizable. Usually a slightly smaller or bigger value is obtained which is additionally dependent on the environmental reception situation (eg. temperature, utilized LO-frequency, etc.). Therefore, we will have to cope with IQ-imbalance which ought to be compensated for digitally, as suggested in the previous section.

VI. SIMULATION RESULTS

In order to verify the theoretical results of the previous sections, we conducted some computer simulations. The receiver architecture of Fig. 1 was utilized as front-end within an UTRA-FDD-like system. A QPSK-modulated signal was transmitted over an AWGN channel. The spectral composition of the completely occupied RF-band (2110-2170MHz) comprises 11 separate modulated channels and is shown in Fig. 3(a). The desired channel $D(f)$ is located in the middle of the RF-band and has the lowest power with respect to the neighboring channels. The shown spectral distribution corresponds to the blocking characteristics of the UTRA FDD standard. It is to mention that this spectral scenario is only defined for single tone blockers and not for modulated blockers. By expanding it to the given situation (Fig. 3(a)), we obtain a real worst case with respect to the maximum

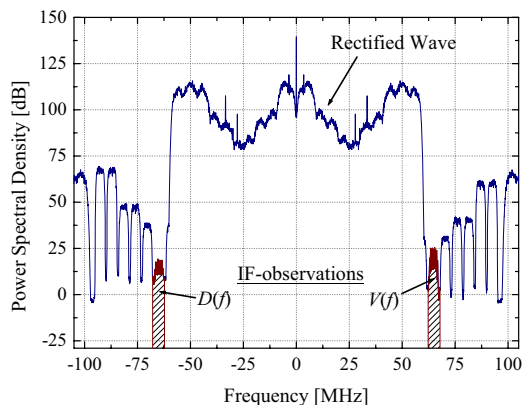

Fig. 4. Power spectral density of IF-signals (IQ-imbalanced IF-observations according to (10)) being located directly next to the rectified wave.

power level of the resulting rectified wave, which is shown in Fig. 3(b). Furthermore, the LO-signal at $f_{LO} = 2202.5\text{MHz}$ and the image signal $\hat{i}(t)$ or $I(f)$, respectively, are given in Fig. 3(a). Hence, the IF-down-conversion results in the smallest possible intermediate frequency for which the channel is not distorted by the rectified wave, i.e. $f_{IF} = 62.5\text{MHz}$. The image signal is considered to have been attenuated by the RF-band filter which results in an approximately 15dB stronger image signal compared to $S(f)$. The attenuation of $I(f)$ before the down-conversion can be realized by a typical RF-band surface acoustic wave (SAW) filter.

In Fig. 4, the spectral scenario at the intermediate frequency is shown. The IF-observations ($D(f)$, $V(f)$) are located at the minimum IF of 62.5MHz for the given system setup. Obviously, a lower IF would cause the desired signals to be distorted or even to be covered completely by the RFS2. Since the rectified wave is a convolution within frequency domain of the incoming RF-band, the power level of the rectified wave is far beyond the level of the strongest in-band signal. This is also indicated by (1)-(4). Hence, even if the strongest in-band signal was the desired one, it would have to be down-converted to a frequency apart from the rectified wave.

Due to the imbalance of the front-end ($G = 0.905$, $\varphi \approx -42^\circ$), $D(f)$ and $V(f)$ comprise a mixture of the desired signal $S(f)$ and the image signal $I(f)$ according to (10). Therefore and because the image signal after the RF-band filter was about 15dB stronger than the desired signal, we can observe $V(f)$ to be significantly stronger ($\approx 10\text{dB}$) than $D(f)$.

Without an appropriate compensation for the IQ-imbalance, the desired signal can not be separated properly. Hence, the demodulation result is insufficient, especially in presence of comparably strong image signals, Fig. 5(a). For the presented system, only linear IQ-imbalance effects are considered since it can be shown for mobile communications that the frequency dependence of the phase and amplitude impairments can be neglected. However, if a suitable de-mixing matrix was obtained (e.g., by an BSS algorithm like described in section IV), the IF-observations of the desired and the image signal can be separated from each other. The result is the expected

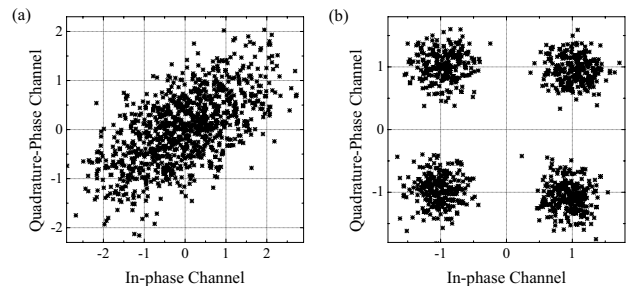

Fig. 5. IQ-constellation of (a) an imbalanced (relative amplitude error: $G = 0.905$ and phase error $\varphi \approx -42^\circ$) and of (b) the respective IQ-regenerated QPSK-signal; $E_b/N_0 = 20\text{dB}$.

QPSK-signal of the desired channel, Fig.5(b).

VII. CONCLUSION

We have presented an alternative front-end system architecture for mobile communications receiver. Instead of conventional multiplicative mixing, a superposition of the RF-signal with the LO-signal is utilized which is followed by a nonlinear processing element to down-convert the signals to an intermediate frequency. The influence of system inherent non-idealities, like the second order RF-self-mixing product and IQ-imbalance, on the architecture as well as on the selection of the IF has been discussed. The general functionality of the front-end architecture was verified within a simulation of an UTRA-FDD-like transmission.

Under the prerequisite to have appropriate IF band-pass filters and analog-to-digital converters, the theoretical investigations in combination with the simulations indicate that the system concept for low analog complexity and high-IF superposition heterodyne receivers can be utilized for mobile communications. Hence, the proposed system could become a candidate for front-end implementations of future wideband mobile communications applications.

ACKNOWLEDGMENT

This research was supported by Siemens AG Munich, Communications, Mobile Devices and Next Generation Technologies BenQ Mobile GmbH & Co. OHG, Germany. Additionally the authors would like to thank the staff of the Information Technology for Traffic Systems Chair at TU Dresden for fruitful discussions.

REFERENCES

- [1] Tim Hentschel, "The Six-Port as a Communications Receiver", IEEE Transactions on Microwave Theory and Techniques (MTT), vol. 53, no. 3, Mar. 2005, pp. 1039-1047.
- [2] Masayoshi Abe, Noboru Sasho, Veselin Brankovic, Dragan Krupcevic, "Direct Conversion MMIC based on Six-Port Technology", in Proceedings of the European Conference on Wireless Technology 2000, ECWT5-1, Paris, Oct. 2000.
- [3] Farbod Behbahani, John C. Leete, Yoji Kishigami, Andreas Roithmeier, Koichi Hoshino and Asad A. Abidi, "A 2.4-GHz Low-IF Receiver for Wideband WLAN in 0.6- μm CMOS Architecture and Front-End", IEEE Journal of Solid-State Circuits, vol. 35, no. 12, Dec. 2000, pp. 1908-1916.
- [4] Won Namgoong, Teresa H. Meng, "Direct-Conversion RF Receiver Design", IEEE Transactions on Communications, vol. 49, no. 3, Mar. 2001, pp. 518-529.

- [5] Raik Richter, Hans-Joachim Jentschel, "An Integrated Wideband-IF-Receiver Architecture for Mobile Terminals", in Proceedings of IEEE Radio Frequency Integrated Circuits (RFIC) Symposium, Philadelphia, USA, Jun. 2003, pp. 583-586.
- [6] Guillaume Neveux, Bernard Huyart, Georges J. Rodriguez-Guisantes, "Wide-band RF Receiver Using the "Five-Port" Technology", IEEE Transactions on Vehicular Technology, vol. 53, no. 5, Sept. 2004.
- [7] Mohamed Ratni, Dragan Krupcevic, Zhaocheng Wang, Jens-Uwe Jürgensen, "Broadband Digital Direct Down Conversion Receiver Suitable for Software Defined Radio", in Proceedings of the 13th IEEE International Symposium on Personal, Indoor and Mobile Radio Communications PIMRC, MPO1.5, Lisbon, Portugal, Sept. 2002, pp. 93-99.
- [8] Marko Mailand, Hans-Joachim Jentschel, "An Effort Reduced Six-Port Direct Conversion Receiver and Its Calibration", in Proceedings of the IEEE Wireless Communications and Networking Conference 2005 (WCNC'2005), New Orleans, USA, Mar. 2005.
- [9] Marko Mailand, Hans-Joachim Jentschel, "Compensation of DC-Offsets and RF-Self-Mixing Products in Six-Port-Based Analog Direct Receivers", in Proceedings of the 14th IST Mobile & Wireless Communications Summit, Dresden, Germany, 19-23 June 2005.
- [10] Mikko Valkama, Markku Renfors, and Visa Koivunen, "Advanced methods for I/Q imbalance compensation in communication receivers", IEEE Transactions on Signal Processing, vol. 49, Oct. 2001, pp. 2335 - 2344.
- [11] Magnus Wiklund, Stefan Nilsson, Christan Bjork, Sven Mattisson, "A 2GHz Image-Reject Receiver in a Low IF Architecture Fabricated in a 0.1 μ m CMOS Technology", in Proceedings of the 2003 International Symposium on Circuits and Systems, 2003(ISCAS'03), Bangkok, Thailand, May 2003.
- [12] Markus Windisch and Gerhard Fettweis, "Blind I/Q Imbalance Parameter Estimation and Compensation in Low-IF Receivers", in Proceedings of the 1st International Symposium on Control, Communications and Signal Processing (ISCCSP), Hammamet, Tunisia, March 2004.
- [13] Marko Mailand, Raik Richter and Hans-Joachim Jentschel, "Nonlinearity Analysis of Power Detectors in Direct Conversion Receivers Utilizing Six-Port Technology", in Proceedings of International Symposium on Signals, Circuits and Systems, ISSCS 2005, Iasi, Romania, 14-15 Jul. 2005.