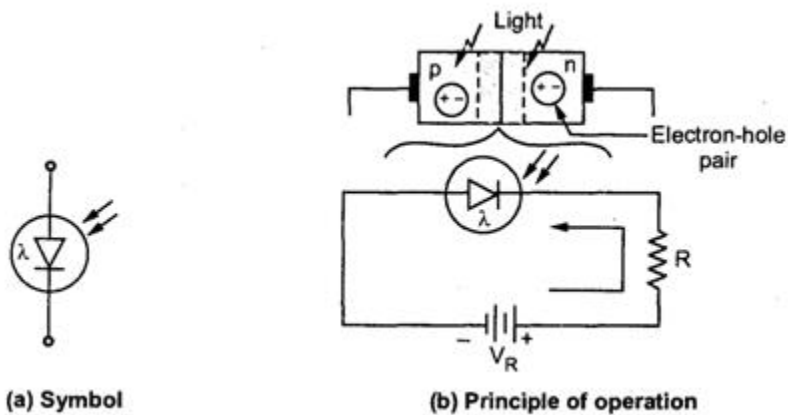

PHOTO-DIODE

The photodiode is a semiconductor p-n junction device whose region of operation is limited to the reverse biased region. The Fig shows the symbol of photodiode while the Fig shows the working principle of photodiode.

The photodiode is connected in reverse biased condition. The depletion region width is large. Under normal condition, it carries small reverse current due to minority charge carriers. When light is incident through glass window on the p-n junction, photons in the light bombard the p-n junction and some energy is imparted to the valence electrons. Due to this, valence electrons are dislodged from the covalent bonds and become free electrons. Thus more electron-hole pairs are generated. Thus total number of minority charge carriers increases and hence the reverse current increases. This is the basic principle of operation of photodiode.



The reverse current without light in diode is in the range of micro amperes. The change in this current due to the light is also in the range of micro amperes. Thus such a change can be significance observed in the reverse current. If the photodiode is forward biased, the current flow through it is in mA. The applied forward biased voltage takes the control of the current instead of the light. The change in forward current due to light is negligible and can not be noticed. The resistance of forward biased diode is not affected by the light. Hence to have significant effect of light on

the current and to operate photodiode as a variable resistance device, it is always connected in reverse biased condition.

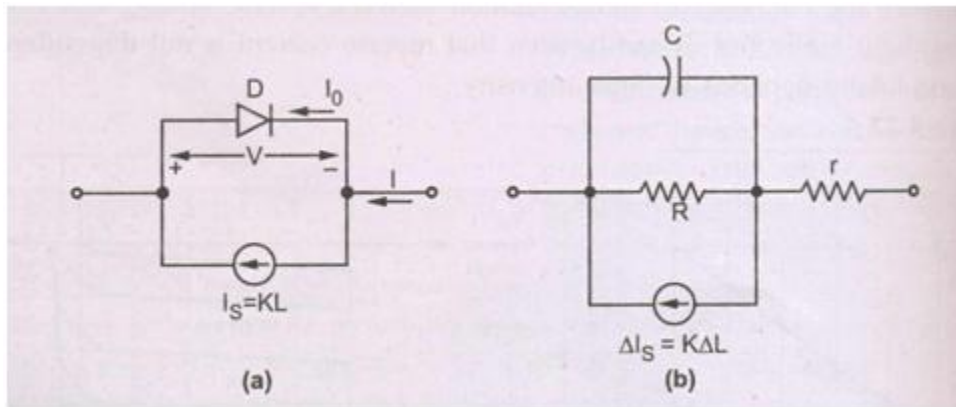

The Fig shows the small signal model for photodiode. Photodiode is represented by an ideal junction diode in parallel with a current source which is proportional to the light intensity.

Advantages

The advantages of photodiode are,

- 1.Can be used as variable resistance device.
- 2.Highly sensitive to the light.
- 3.The speed of operation is very high. The switching of current and hence the resistance value from high to low or otherwise is very fast.

Disadvantages

The various disadvantages of photodiode are,

- 1.The dark current is temperature dependent.

2.The overall photodiode characteristics are temperature dependent hence have poor

3.temperature stability.

4.The current and change in current is in the range of 1 which may not be sufficient to drive other circuits. Hence amplification is necessary.

Photodiode Applications

The two commonly used systems using photodiode are alarm system and a counting system.

Source : <http://mediatoget.blogspot.in/2011/09/photo-diode.html>