

Module 2

AC to DC Converters

Lesson

10

Single Phase Fully Controlled Rectifier

Operation and Analysis of single phase fully controlled converter.

Instructional Objectives

On completion the student will be able to

- Differentiate between the constructional and operation features of uncontrolled and controlled converters
- Draw the waveforms and calculate their average and RMS values of different variables associated with a single phase fully controlled half wave converter.
- Explain the operating principle of a single phase fully controlled bridge converter.
- Identify the mode of operation of the converter (continuous or discontinuous) for a given load parameters and firing angle.
- Analyze the converter operation in both continuous and discontinuous conduction mode and there by find out the average and RMS values of input/output, voltage/currents.
- Explain the operation of the converter in the inverter mode.

10.1 Introduction

Single phase uncontrolled rectifiers are extensively used in a number of power electronic based converters. In most cases they are used to provide an intermediate unregulated dc voltage source which is further processed to obtain a regulated dc or ac output. They have, in general, been proved to be efficient and robust power stages. However, they suffer from a few disadvantages. The main among them is their inability to control the output dc voltage / current magnitude when the input ac voltage and load parameters remain fixed. They are also unidirectional in the sense that they allow electrical power to flow from the ac side to the dc side only. These two disadvantages are the direct consequences of using power diodes in these converters which can block voltage only in one direction. As will be shown in this module, these two disadvantages are overcome if the diodes are replaced by thyristors, the resulting converters are called fully controlled converters.

Thyristors are semiconducted devices which can be turned ON by applying a current pulse at its gate terminal at a desired instance. However, they cannot be turned off from the gate terminals. Therefore, the fully controlled converter continues to exhibit load dependent output voltage / current waveforms as in the case of their uncontrolled counterpart. However, since the thyristor can block forward voltage, the output voltage / current magnitude can be controlled by controlling the turn on instants of the thyristors. Working principle of thyristors based single phase fully controlled converters will be explained first in the case of a single thyristor halfwave rectifier circuit supplying an R or R-L load. However, such converters are rarely used in practice.

Full bridge is the most popular configuration used with single phase fully controlled rectifiers. Analysis and performance of this rectifier supplying an R-L-E load (which may represent a dc motor) will be studied in detail in this lesson.

10.2 Single phase fully controlled halfwave rectifier

10.2.1 Resistive load

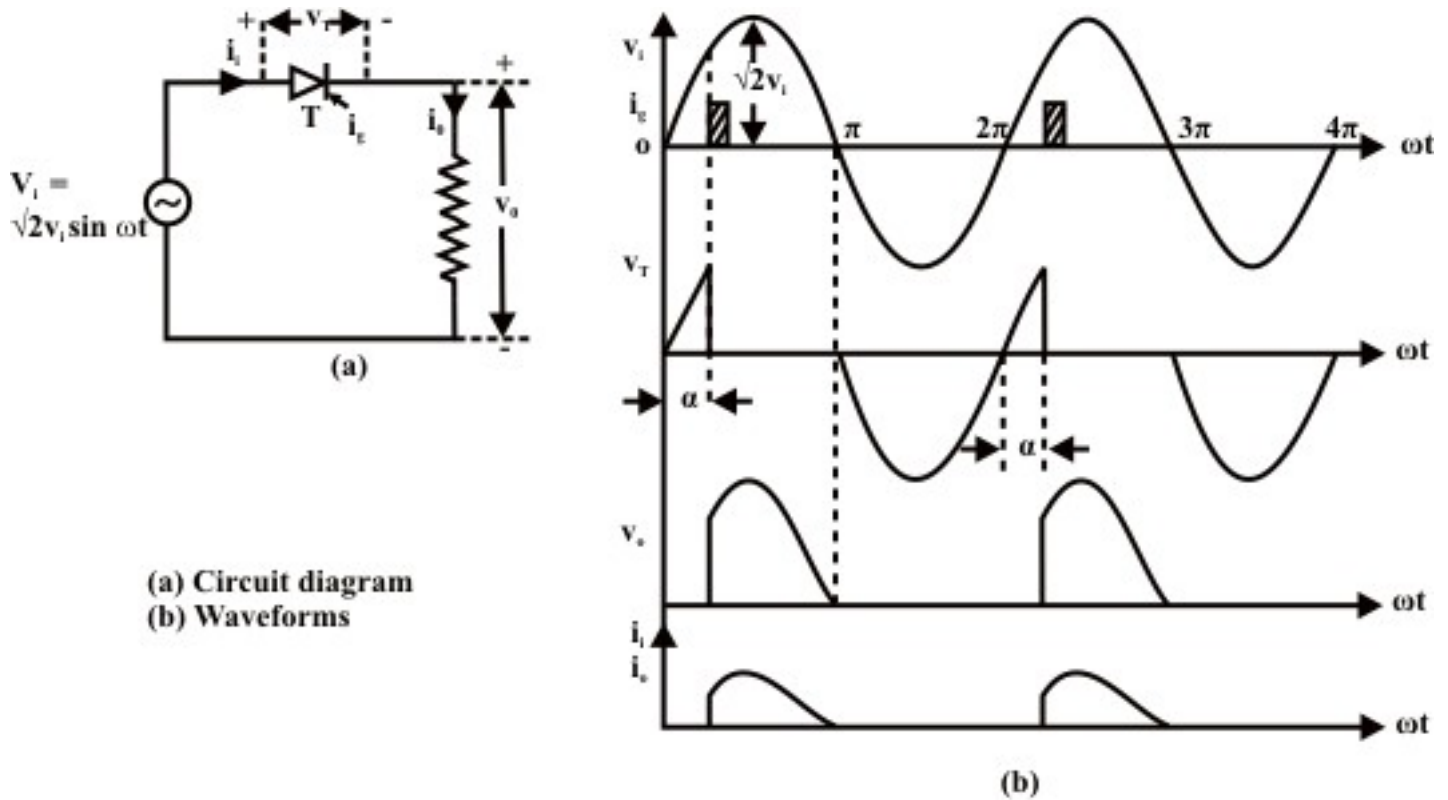

Fig. 10.1: Single phase fully controlled half wave rectifier supplying a resistive load

Fig.10. 1(a) shows the circuit diagram of a single phase fully controlled halfwave rectifier supplying a purely resistive load. At $\omega t = 0$ when the input supply voltage becomes positive the thyristor T becomes forward biased. However, unlike a diode, it does not turn ON till a gate pulse is applied at $\omega t = \alpha$. During the period $0 < \omega t \leq \alpha$, the thyristor blocks the supply voltage and the load voltage remains zero as shown in fig 10.1(b). Consequently, no load current flows during this interval. As soon as a gate pulse is applied to the thyristor at $\omega t = \alpha$ it turns ON. The voltage across the thyristor collapses to almost zero and the full supply voltage appears across the load. From this point onwards the load voltage follows the supply voltage. The load being purely resistive the load current i_o is proportional to the load voltage. At $\omega t = \pi$ as the supply voltage passes through the negative going zero crossing the load voltage and hence the load current becomes zero and tries to reverse direction. In the process the thyristor undergoes reverse recovery and starts blocking the negative supply voltage. Therefore, the load voltage and the load current remains clamped at zero till the thyristor is fired again at $\omega t = 2\pi + \alpha$. The same process repeats there after.

From the discussion above and Fig 10.1 (b) one can write

$$\text{For } \alpha < \omega t \leq \pi$$

$$v_o = v_i = \sqrt{2} V_i \sin \omega t \quad (10.1)$$

$$i_o = \frac{v_o}{R} = \sqrt{2} \frac{V_i}{R} \sin \omega t \quad (10.2)$$

$v_0 = i_0 = 0$ otherwise.

Therefore
$$V_{OAV} = \frac{1}{2\pi} \int_0^{2\pi} v_0 d\omega t = \frac{1}{2\pi} \int_\alpha^\pi \sqrt{2} V_i \sin\omega t d\omega t \quad (10.3)$$

Or
$$V_{OAV} = \frac{V_i}{\sqrt{2\pi}} (1 + \cos\alpha) \quad (10.4)$$

$$V_{ORMS} = \sqrt{\frac{1}{2\pi} \int_0^{2\pi} v_0^2 d\omega t} \quad (10.5)$$

$$= \sqrt{\frac{1}{2\pi} \int_\alpha^\pi 2V_i^2 \sin^2\omega t d\omega t}$$

$$= \sqrt{\frac{V_i^2}{2\pi} \int_\alpha^\pi (1 - \cos 2\omega t) d\omega t}$$

$$= \sqrt{\frac{V_i^2}{2\pi} \left[\pi - \alpha + \frac{\sin 2\alpha}{2} \right]}$$

$$= \frac{V_i}{\sqrt{2}} \left(1 - \frac{\alpha}{\pi} + \frac{\sin 2\alpha}{2\pi} \right)^{\frac{1}{2}}$$

$$\therefore FF_{VO} = \frac{V_{ORMS}}{V_{OAV}} = \frac{\pi \left(1 - \frac{\alpha}{\pi} + \frac{\sin 2\alpha}{2\pi} \right)^{\frac{1}{2}}}{(1 + \cos\alpha)} \quad (10.6)$$

Similar calculation can be done for i_0 . In particulars for pure resistive loads $FF_{i_0} = FF_{v_0}$.

10.2.2 Resistive-Inductive load

Fig 10.2 (a) and (b) shows the circuit diagram and the waveforms of a single phase fully controlled halfwave rectifier supplying a resistive inductive load. Although this circuit is hardly used in practice its analysis does provide useful insight into the operation of fully controlled rectifiers which will help to appreciate the operation of single phase bridge converters to be discussed later.

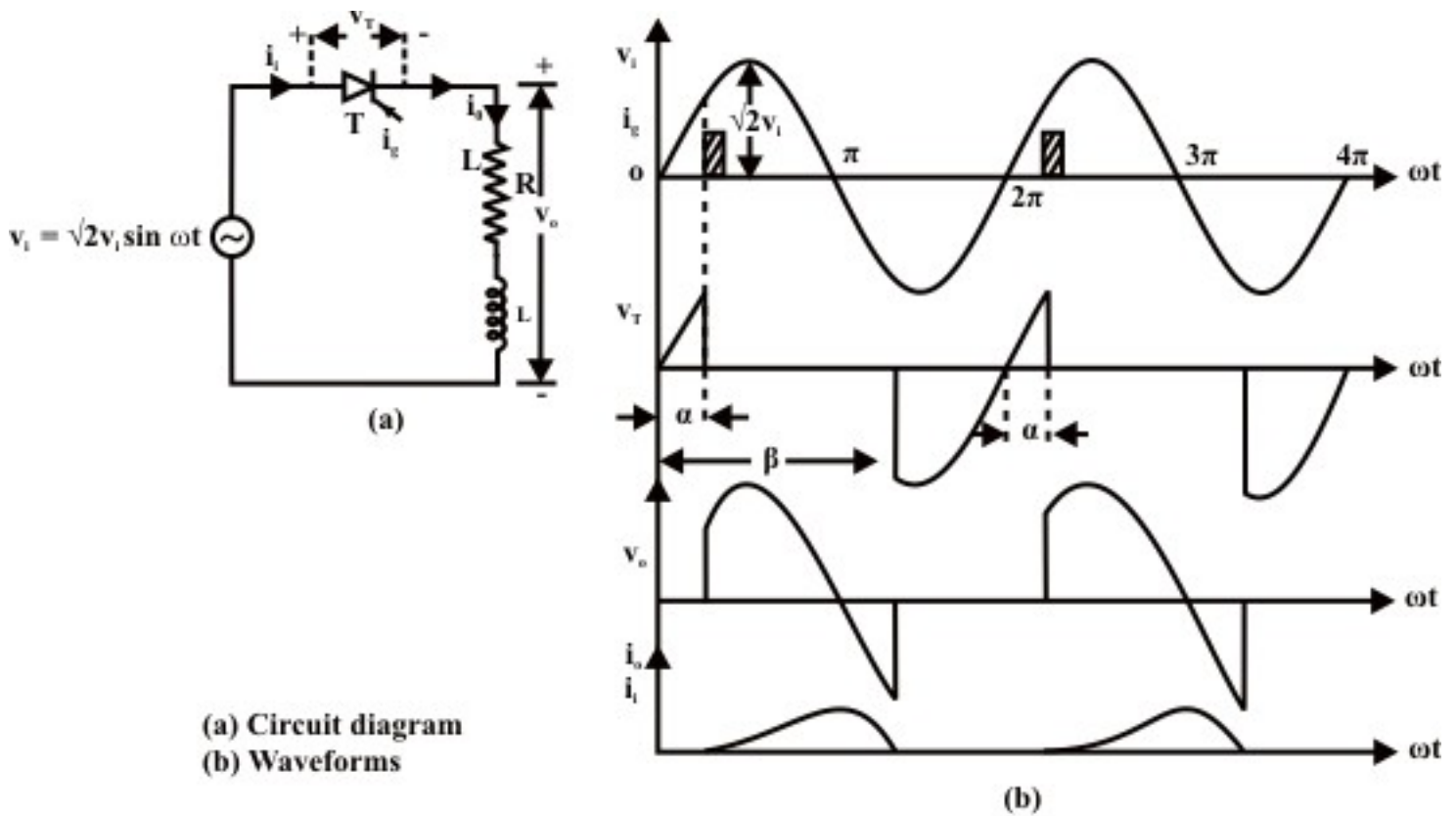

Fig. 10.2: Single phase fully controlled half wave rectifier supplying a resistive inductive load

As in the case of a resistive load, the thyristor T becomes forward biased when the supply voltage becomes positive at $\omega t = 0$. However, it does not start conduction until a gate pulse is applied at $\omega t = \alpha$. As the thyristor turns ON at $\omega t = \alpha$ the input voltage appears across the load and the load current starts building up. However, unlike a resistive load, the load current does not become zero at $\omega t = \pi$, instead it continues to flow through the thyristor and the negative supply voltage appears across the load forcing the load current to decrease. Finally, at $\omega t = \beta$ ($\beta > \pi$) the load current becomes zero and the thyristor undergoes reverse recovery. From this point onwards the thyristor starts blocking the supply voltage and the load voltage remains zero until the thyristor is turned ON again in the next cycle. It is to be noted that the value of β depends on the load parameters. Therefore, unlike the resistive load the average and RMS output voltage depends on the load parameters. Since the thyristors does not conduct over the entire input supply cycle this mode of operation is called the “discontinuous conduction mode”.

From above discussion one can write.

$$\text{For } \alpha \leq \omega t \leq \beta$$

$$v_o = v_i = \sqrt{2} V_i \sin \omega t \quad (10.7)$$

$$v_o = 0 \text{ otherwise}$$

$$\text{Therefore } V_{OAV} = \frac{1}{2\pi} \int_0^{2\pi} v_o d\omega t \quad (10.8)$$

$$= \frac{1}{2\pi} \int_{\alpha}^{\beta} \sqrt{2} V_i \sin \omega t d\omega t$$

$$= \frac{V_i}{\sqrt{2\pi}} (\cos\alpha - \cos\beta)$$

$$V_{\text{ORMS}} = \sqrt{\frac{1}{2\pi} \int_0^{2\pi} v_0^2 d\omega t} \quad (10.9)$$

$$= \sqrt{\frac{1}{2\pi} \int_\alpha^\beta 2V_i^2 \sin^2 \omega t d\omega t}$$

$$= \frac{V_i}{\sqrt{2}} \left(\frac{\beta - \alpha}{\pi} + \frac{\sin 2\alpha - \sin 2\beta}{2\pi} \right)^{\frac{1}{2}}$$

$$I_{\text{OAV}} = \frac{V_{\text{OAV}}}{R} = \frac{V_i}{\sqrt{2\pi}R} (\cos\alpha - \cos\beta) \quad (10.10)$$

Since the average voltage drop across the inductor is zero.

However, I_{ORMS} can not be obtained from V_{ORMS} directly. For that a closed form expression for i_0 will be required. The value of β in terms of the circuit parameters can also be found from the expression of i_0 .

For $\alpha \leq \omega t \leq \beta$

$$Ri_0 + L \frac{di_0}{dt} = v_0 = \sqrt{2}V_i \sin \omega t \quad (10.11)$$

The general solution of which is given by

$$i_0 = I_0 e^{-\frac{(\omega t - \alpha)}{\tan \phi}} + \frac{\sqrt{2}V_i}{Z} \sin(\omega t - \phi) \quad (10.12)$$

Where $\tan \phi = \frac{\omega L}{R}$ and $Z = \sqrt{R^2 + \omega^2 L^2}$

$$i_0 \Big|_{\omega t = \alpha} = 0$$

$$\therefore 0 = I_0 + \frac{\sqrt{2}V_i}{Z} \sin(\alpha - \phi)$$

$$\therefore i_0 = \frac{\sqrt{2}V_i}{Z} \left[\sin(\phi - \alpha) e^{-\frac{(\omega t - \alpha)}{\tan \phi}} + \sin(\omega t - \phi) \right] \quad (10.13)$$

$i_0 = 0$ otherwise.

Equation (10.13) can be used to find out I_{ORMS} . To find out β it is noted that

$$i_0 \Big|_{\omega t = \beta} = 0$$

$$\therefore \sin(\phi - \alpha) e^{\frac{\alpha - \beta}{\tan \phi}} = \sin(\phi - \beta) \quad (10.14)$$

Equation (10.14) can be solved to find out β

Exercise 10.1

Fill in the blank(s) with appropriate word(s)

- i) In a single phase fully controlled converter the _____ of an uncontrolled converters are replaced by _____.
- ii) In a fully controlled converter the load voltage is controlled by controlling the _____ of the converter.
- iii) A single phase half wave controlled converter always operates in the _____ conduction mode.
- iv) The voltage form factor of a single phase fully controlled half wave converter with a resistive inductive load is _____ compared to the same converter with a resistive load.
- v) The load current form factor of a single phase fully controlled half wave converter with a resistive inductive load is _____ compared to the same converter with a resistive load.

Answers: (i) diodes, thyristors; (ii) firing angle; (iii) discontinuous (iv) poorer; (v) better.

- 2) Explain qualitatively, what will happen if a free-wheeling diode(cathode of the diode shorted with the cathode of the thyristor) is connected across the load in Fig 10.2.(a)

Answer: Referring to Fig 10.2(b), the free wheeling diode will remain off till $\omega t = \pi$ since the positive load voltage across the load will reverse bias the diode. However, beyond this point as the load voltage tends to become negative the free wheeling diode comes into conduction. The load voltage is clamped to zero there after. As a result

- i) Average load voltage increases
- ii) RMS load voltage reduces and hence the load voltage form factor reduces.
- iii) Conduction angle of load current increases as does its average value. The load current ripple factor reduces.

10.3 Single phase fully controlled bridge converter

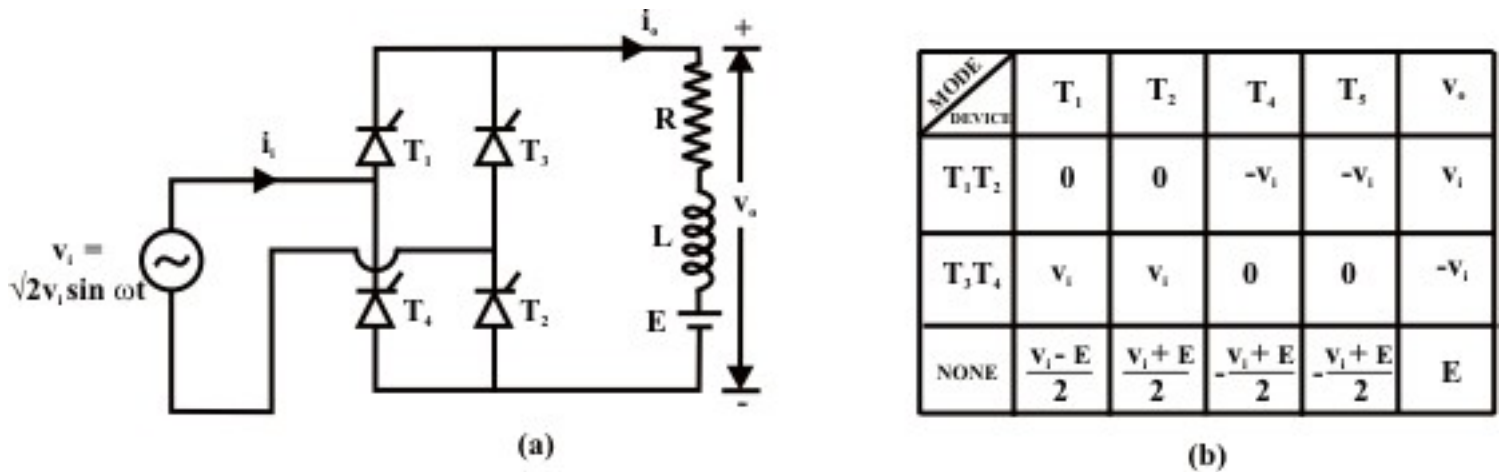

Fig 10.3: Single phase fully controlled bridge converter supplying an R - L - E load. (a) Circuit diagram, (b) Conduction table

Fig 10.3 (a) shows the circuit diagram of a single phase fully controlled bridge converter. It is one of the most popular converter circuits and is widely used in the speed control of separately excited dc machines. Indeed, the R–L–E load shown in this figure may represent the electrical equivalent circuit of a separately excited dc motor.

The single phase fully controlled bridge converter is obtained by replacing all the diode of the corresponding uncontrolled converter by thyristors. Thyristors T₁ and T₂ are fired together while T₃ and T₄ are fired 180° after T₁ and T₂. From the circuit diagram of Fig 10.3(a) it is clear that for any load current to flow at least one thyristor from the top group (T₁, T₃) and one thyristor from the bottom group (T₂, T₄) must conduct. It can also be argued that neither T₁T₃ nor T₂T₄ can conduct simultaneously. For example whenever T₃ and T₄ are in the forward blocking state and a gate pulse is applied to them, they turn ON and at the same time a negative voltage is applied across T₁ and T₂ commutating them immediately. Similar argument holds for T₁ and T₂.

For the same reason T₁T₄ or T₂T₃ can not conduct simultaneously. Therefore, the only possible conduction modes when the current i_o can flow are T₁T₂ and T₃T₄. Of course it is possible that at a given moment none of the thyristors conduct. This situation will typically occur when the load current becomes zero in between the firings of T₁T₂ and T₃T₄. Once the load current becomes zero all thyristors remain off. In this mode the load current remains zero. Consequently the converter is said to be operating in the discontinuous conduction mode.

Fig 10.3(b) shows the voltage across different devices and the dc output voltage during each of these conduction modes. It is to be noted that whenever T₁ and T₂ conducts, the voltage across T₃ and T₄ becomes -v_i. Therefore T₃ and T₄ can be fired only when v_i is negative i.e, over the negative half cycle of the input supply voltage. Similarly T₁ and T₂ can be fired only over the positive half cycle of the input supply. The voltage across the devices when none of the thyristors conduct depends on the off state impedance of each device. The values listed in Fig 10.3 (b) assume identical devices.

Under normal operating condition of the converter the load current may or may not remain zero over some interval of the input voltage cycle. If i_o is always greater than zero then the converter is said to be operating in the continuous conduction mode. In this mode of operation of the converter T₁T₂ and T₃T₄ conducts for alternate half cycle of the input supply.

However, in the discontinuous conduction mode none of the thyristors conduct over some portion of the input cycle. The load current remains zero during that period.

10.3.1 Operation in the continuous conduction mode

As has been explained earlier in the continuous conduction mode of operation i_0 never becomes zero, therefore, either T_1T_2 or T_3T_4 conducts. Fig 10.4 shows the waveforms of different variables in the steady state. The firing angle of the converter is α . The angle θ is given by

$$\sin\theta = \frac{E}{\sqrt{2}V_1} \quad (10.15)$$

It is assumed that at $t = 0^-$ T_3T_4 was conducting. As T_1T_2 are fired at $\omega t = \alpha$ they turn on commutating T_3T_4 immediately. T_3T_4 are again fired at $\omega t = \pi + \alpha$. Till this point T_1T_2 conducts. The period of conduction of different thyristors are pictorially depicted in the second waveform (also called the conduction diagram) of Fig 10.4.

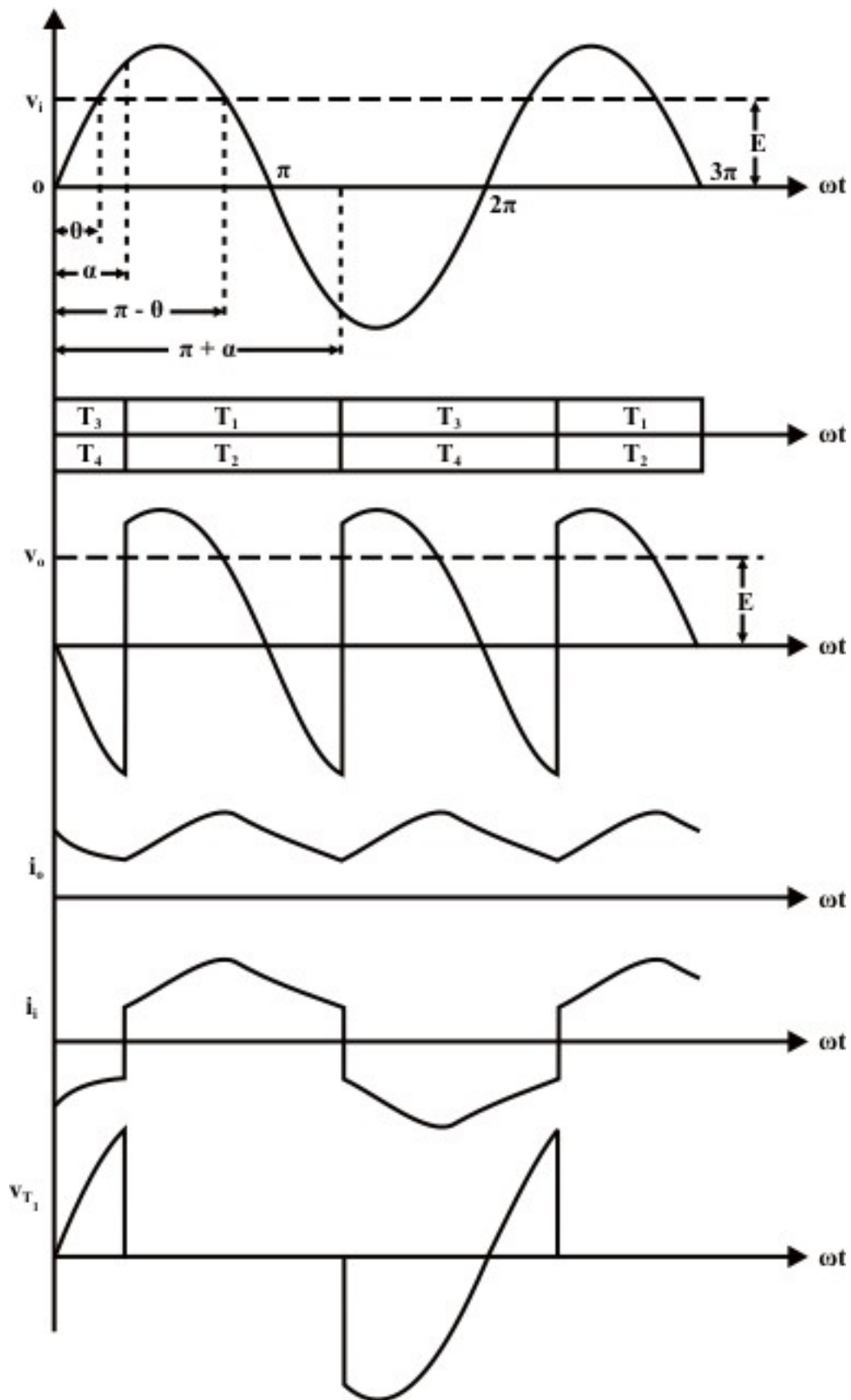

Fig. 10.4: Waveforms in Single phase fully controlled bridge converter in continuous conduction mode.

The dc link voltage waveform shown next follows from this conduction diagram and the conduction table shown in Fig 10.3(b). It is observed that the emf source E is greater than the dc link voltage till $\omega t = \alpha$. Therefore, the load current i_0 continues to fall till this point. However, as T_1T_2 are fired at this point v_0 becomes greater than E and i_0 starts increasing through R-L and E . At $\omega t = \pi - \theta$ v_0 again equals E . Depending upon the load circuit parameters i_0 reaches its maximum at around this point and starts falling afterwards. Continuous conduction mode will be possible only if i_0 remains greater than zero till T_3T_4 are fired at $\omega t = \pi + \alpha$ where upon the same process repeats. The resulting i_0 waveform is shown below v_0 . The input ac current waveform i_i is obtained from i_0 by noting that whenever T_1T_2 conducts $i_i = i_0$ and $i_i = -i_0$ whenever T_3T_4 conducts. The last waveform shows the typical voltage waveform across the thyristor T_1 . It is to be noted that when the thyristor turns off at $\omega t = \pi + \alpha$ a negative voltage is applied across it for a duration of $\pi - \alpha$. The thyristor must turn off during this interval for successful operation of the converter.

It is noted that the dc voltage waveform is periodic over half the input cycle. Therefore, it can be expressed in a Fourier series as follows.

$$v_0 = V_{OAV} + \sum_{n=1}^{\infty} [v_{an} \cos 2n\omega t + v_{bn} \sin 2n\omega t] \quad (10.16)$$

Where
$$V_{OAV} = \frac{1}{\pi} \int_{\alpha}^{\pi+\alpha} v_0 d\omega t = \frac{2\sqrt{2}}{\pi} V_i \cos \alpha \quad (10.17)$$

$$v_{an} = \frac{2}{\pi} \int_0^{\pi} v_0 \cos 2n\omega t d\omega t = \frac{2\sqrt{2}}{\pi} V_i \left[\frac{\cos(2n+1)\alpha}{2n+1} - \frac{\cos(2n-1)\alpha}{2n-1} \right] \quad (10.18)$$

$$v_{bn} = \frac{2}{\pi} \int_0^{\pi} v_0 \sin 2n\omega t d\omega t = \frac{2\sqrt{2}}{\pi} V_i \left[\frac{\sin(2n+1)\alpha}{2n+1} - \frac{\sin(2n-1)\alpha}{2n-1} \right] \quad (10.19)$$

Therefore the RMS value of the nth harmonic

$$V_{OnRMS} = \frac{1}{\sqrt{2}} \sqrt{v_{an}^2 + v_{bn}^2} \quad (10.20)$$

RMS value of v_0 can of course be completed directly from.

$$V_{ORMS} = \sqrt{\frac{1}{\pi} \int_{\alpha}^{\pi+\alpha} v_0^2 d\omega t} = V_i \quad (10.21)$$

Fourier series expression of v_0 is important because it provides a simple method of estimating individual and total RMS harmonic current injected into the load as follows:

The impedance offered by the load at nth harmonic frequency is given by

$$Z_n = \sqrt{R^2 + (2n\omega L)^2} \quad (10.22)$$

$$I_{onRMS} = \frac{V_{onRMS}}{Z_n}; I_{OHRMS} = \left[\sum_{n=1}^{\infty} I_{onRMS}^2 \right]^{\frac{1}{2}} \quad (10.23)$$

From (10.18) – (10.23) it can be argued that in an inductive circuit $I_{onRMS} \rightarrow 0$ as fast as $1/n^2$. So in practice it will be sufficient to consider only first few harmonics to obtain a reasonably accurate estimate of I_{OHRMS} from equation 10.23. This method will be useful, for example, while calculating the required current derating of a dc motor to be used with such a converter.

However to obtain the current rating of the device to be used it is necessary to find out a closed form expression of i_0 . This will also help to establish the condition under which the converter will operate in the continuous conduction mode.

To begin with we observe that the voltage waveform and hence the current waveform is periodic over an interval π . Therefore, finding out an expression for i_0 over any interval of length π will be sufficient. We choose the interval $\alpha \leq \omega t \leq \pi + \alpha$.

In this interval

$$L \frac{di_0}{dt} + Ri_0 + E = \sqrt{2}V_i \sin\omega t \quad (10.24)$$

The general solution of which is given by

$$i_0 = Ie^{-\frac{(\omega t - \alpha)}{\tan\phi}} + \frac{\sqrt{2}V_i}{Z} \left[\sin(\omega t - \phi) - \frac{\sin\theta}{\cos\phi} \right] \quad (10.25)$$

Where, $Z = \sqrt{R^2 + \omega^2 L^2}$; $\tan\phi = \frac{\omega L}{R}$; $E = \sqrt{2}V_i \sin\theta$; $R = Z \cos\phi$

Now at steady state $i_0|_{\omega t = \alpha} = i_0|_{\omega t = \pi + \alpha}$ since i_0 is periodic over the chosen interval. Using this boundary condition we obtain

$$i_0 = \frac{\sqrt{2}V_i}{Z} \left[\frac{2\sin(\phi - \alpha)}{1 - e^{-\frac{\pi}{\tan\phi}}} e^{-\frac{(\omega t - \alpha)}{\tan\phi}} + \sin(\omega t - \phi) - \frac{\sin\theta}{\cos\phi} \right] \quad (10.26)$$

The input current i_i is related to i_0 as follows:

$$\begin{aligned} i_i &= i_0 \quad \text{for } \alpha \leq \omega t \leq \pi + \alpha \\ i_i &= -i_0 \quad \text{otherwise.} \end{aligned} \quad (10.27)$$

Fig 10.5 shows the waveform of i_i in relation to the v_i waveform.

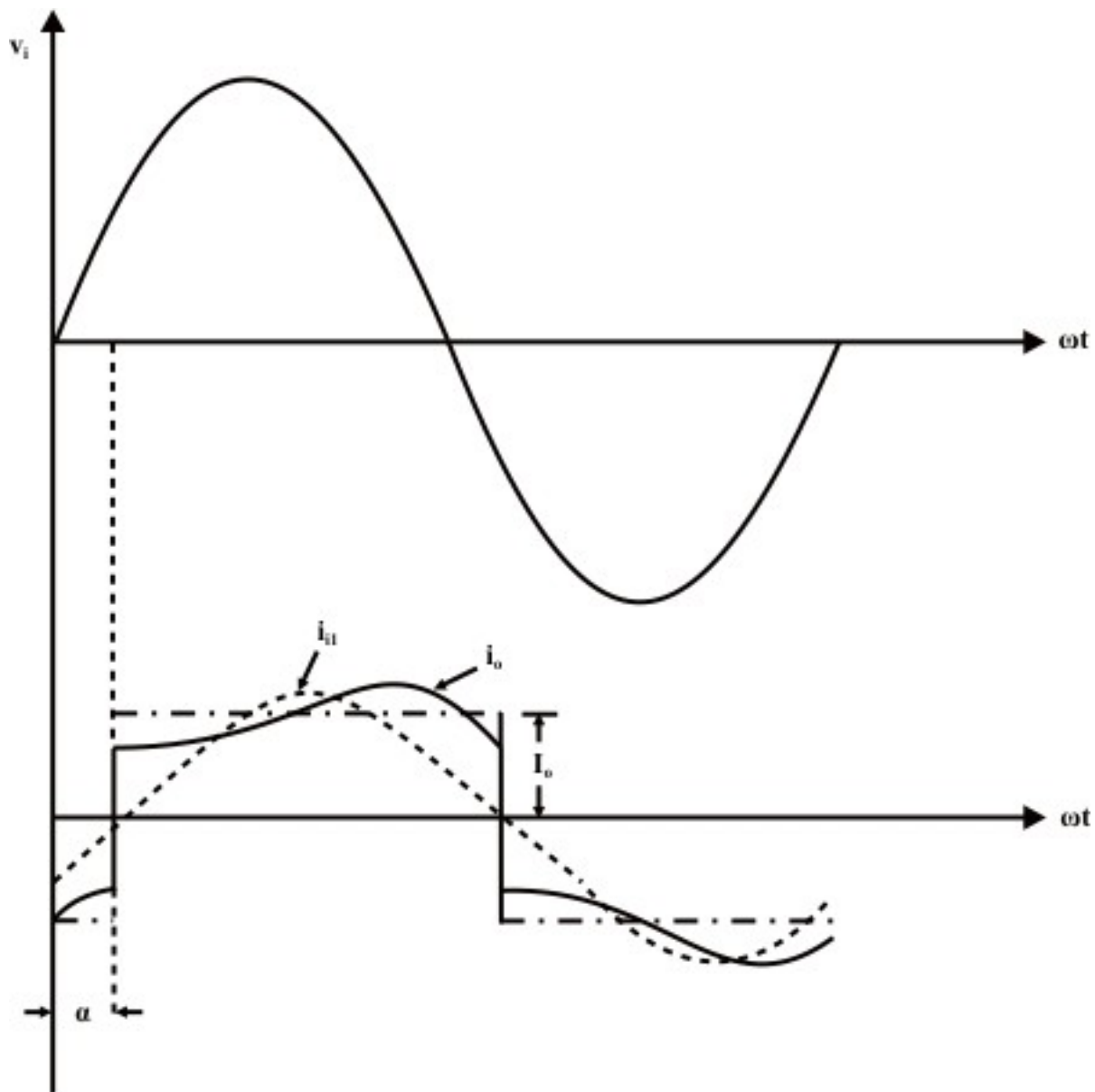

Fig. 10.5: The input current and its fundamental component

It will be of interest to find out a Fourier series expression of i_i . However, using actual expression for i_i will lead to exceedingly complex calculation. Significant simplification can be made by replacing i_0 with its average value I_0 . This will be justified provided the load is highly inductive and the ripple on i_0 is negligible compared to I_0 . Under this assumption the idealized waveform of i_i becomes a square wave with transitions at $\omega t = \alpha$ and $\omega t = \alpha + \pi$ as shown in Fig 10.5. i_{i1} is the fundamental component of this idealized i_i .

Evidently the input current displacement factor defined as the cosine of the angle between input voltage (v_i) and the fundamental component of input current (i_{i1}) waveforms is $\cos\alpha$ (lagging).

It can be shown that

$$I_{i1\text{RMS}} = \frac{2\sqrt{2}}{\pi} I_0 \quad (10.28)$$

and $I_{iRMS} = I_0$ (10.29)

Therefore the input current distortion factor $= \frac{I_{i1RMS}}{I_{iRMS}} = \frac{2\sqrt{2}}{\pi}$ (10.30)

The input power factor $= \frac{\text{Actual Power}}{\text{Apparent Power}} = \frac{V_i I_{i1RMS} \cos\alpha}{V_i I_{iRMS}}$
 $= \frac{2\sqrt{2}}{\pi} \cos\alpha$ (lagging) (10.31)

Therefore, the rectifier appears as a lagging power factor load to the input ac system. Larger the 'α' poorer is the power factor.

The input current i_i also contain significant amount of harmonic current (3rd, 5th, etc) and therefore appears as a harmonic source to the utility. Exact composition of the harmonic currents can be obtained by Fourier series analysis of i_i and is left as an exercise.

Exercise 10.2

Fill in the blank(s) with the appropriate word(s).

- i) A single phase fully controlled bridge converter can operate either in the _____ or _____ conduction mode.
- ii) In the continuous conduction mode at least _____ thyristors conduct at all times.
- iii) In the continuous conduction mode the output voltage waveform does not depend on the _____ parameters.
- iv) The minimum frequency of the output voltage harmonic in a single phase fully controlled bridge converter is _____ the input supply frequency.
- v) The input displacement factor of a single phase fully controlled bridge converter in the continuous conduction mode is equal to the cosine of the _____ angle.

Answer: (i) continuous, discontinuous; (ii) two; (iii) load; (iv) twice; (v) firing.

2. A single phase fully controlled bridge converter operates in the continuous conduction mode from a 230V, 50HZ single phase supply with a firing angle $\alpha = 30^\circ$. The load resistance and inductances are 10Ω and 50mH respectively. Find out the 6th harmonic load current as a percentage of the average load current.

Answer: The average dc output voltage is

$$V_{OAV} = \frac{2\sqrt{2}}{\pi} V_i \cos\alpha = 179.33 \text{ Volts}$$

$$\text{Average output load current} = \frac{V_{OAV}}{R_L} = 17.93 \text{ Amps}$$

$$\text{From equation (10.18) } V_{a3} = 10.25 \text{ Volts}$$

$$\text{From equation (10.19) } V_{b3} = 35.5 \text{ Volts}$$

$$\therefore V_{03RMS} = 26.126 \text{ Volts, } Z_3 = \sqrt{R_L^2 + (6 \times 2 \times \pi \times 50 \times 50 \times 10^{-3})^2} = 94.78 \text{ ohms}$$

$$\therefore I_{3\text{RMS}} = \frac{V_{03\text{RMS}}}{Z_3} = 0.2756 \text{ Amps} = 1.54\% \text{ of } I_{\text{OAV}}.$$

10.3.2 Operation in the discontinuous conduction mode

So far we have assumed that the converter operates in continuous conduction mode without paying attention to the load condition required for it. In figure 10.4 the voltage across the R and L component of the load is negative in the region $\pi - \theta \leq \omega t \leq \pi + \alpha$. Therefore i_0 continues to decrease till a new pair of thyristor is fired at $\omega t = \pi + \alpha$. Now if the value of R, L and E are such that i_0 becomes zero before $\omega t = \pi + \alpha$ the conduction becomes discontinuous. Obviously then, at the boundary between continuous and discontinuous conduction the minimum value of i_0 which occurs at $\omega t = \alpha$ and $\omega t = \pi + \alpha$ will be zero. Putting this condition in (10.26) we obtain the condition for continuous conduction as.

$$\frac{2\sin(\varphi - \alpha)}{1 - e^{-\frac{\pi}{\tan\varphi}}} - \sin(\varphi - \alpha) - \frac{\sin\theta}{\cos\varphi} \geq 0 \quad (10.32)$$

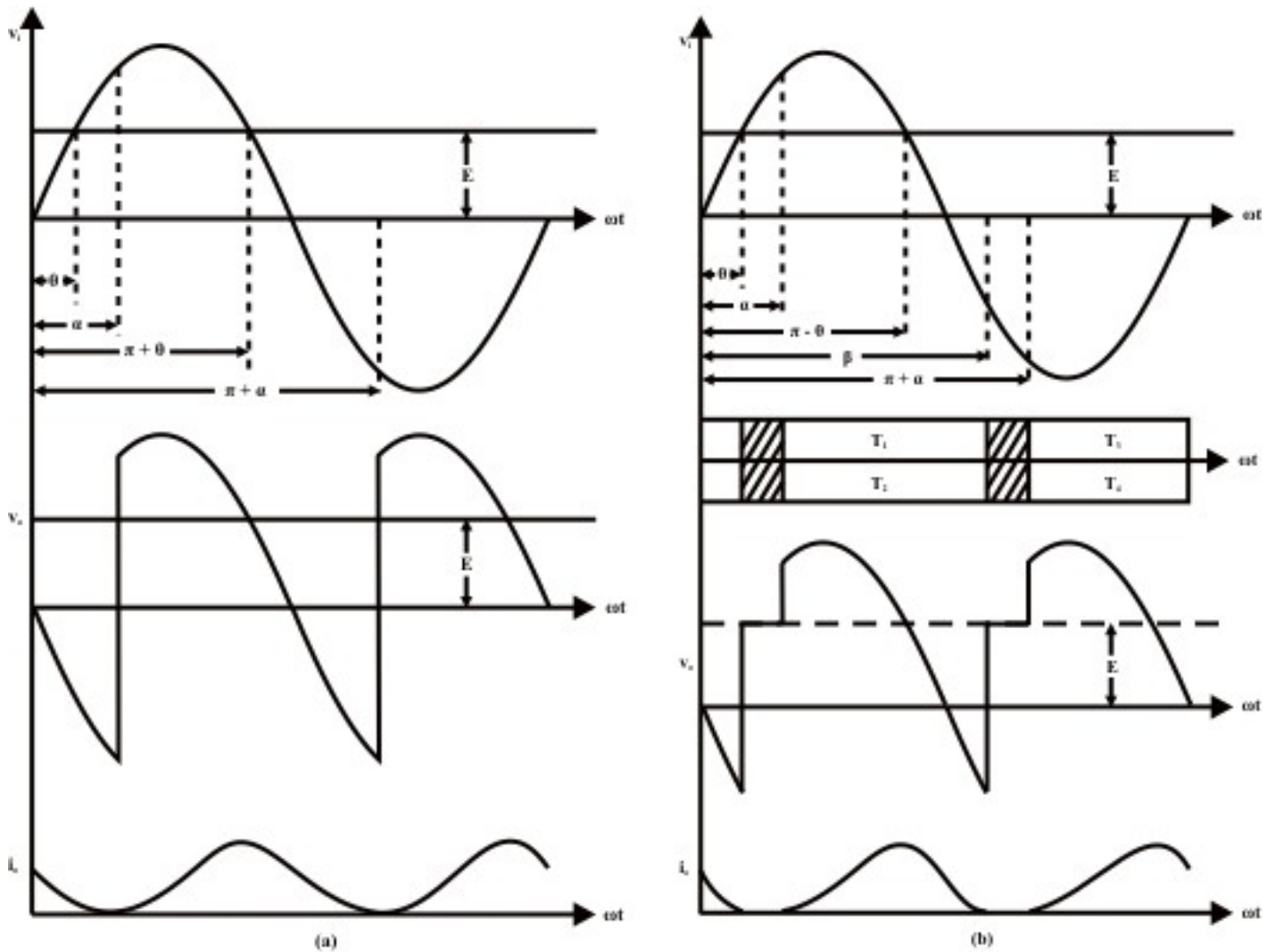

Fig. 10.6: Single phase fully controlled converter in the discontinuous conduction mode (a) on the boundary between continuous and discontinuous conduction; (b) in discontinuous conduction

Fig 10.6 shows waveforms of different variables on the boundary between continuous and discontinuous conduction modes and in the discontinuous conduction mode. It should be stressed that on the boundary between continuous and discontinuous conduction modes the load current is still continuous. Therefore, all the analysis of continuous conduction mode applies to this case as well. However in the discontinuous conduction mode i_0 remains zero for certain interval. During this interval none of the thyristors conduct. These intervals are shown by hatched lines in the conduction diagram of Fig 10.6(b). In this conduction mode i_0 starts rising from zero as T_1T_2 are fired at $\omega t = \alpha$. The load current continues to increase till $\omega t = \pi - \theta$. After this, the output voltage v_0 falls below the emf E and i_0 decreases till $\omega t = \beta$ when it becomes zero. Since the thyristors cannot conduct current in the reverse direction i_0 remains at zero till $\omega t = \pi + \alpha$ when T_3 and T_4 are fired. During the period $\beta \leq \omega t \leq \pi + \alpha$ none of the thyristors conduct. During this period v_0 attains the value E .

Performance of the rectifier such as V_{OAV} , V_{ORMS} , I_{OAV} , I_{ORMS} etc can be found in terms of α , β and θ . For example

$$V_{OAV} = \frac{1}{\pi} \int_{\alpha}^{\pi+\alpha} v_0 d\omega t = \frac{1}{\pi} \left[\int_{\alpha}^{\beta} \sqrt{2}V_i \sin\omega t d\omega t + \int_{\beta}^{\pi+\alpha} \sqrt{2}V_i \sin\theta d\omega t \right] \quad (10.33)$$

$$\text{Or } V_{OAV} = \frac{\sqrt{2}V_i}{\pi} [\cos\alpha - \cos\beta + \sin\theta(\pi + \alpha - \beta)] \quad (10.34)$$

$$I_{OAV} = \frac{V_{OAV} - E}{R} = \frac{V_{OAV} - \sqrt{2}V_i \sin\theta}{Z \cos\phi} \quad (10.35)$$

$$\text{Or } I_{OAV} = \frac{\sqrt{2}V_i}{\pi Z \cos\phi} [\cos\alpha - \cos\beta + \sin\theta(\alpha - \beta)] \quad (10.36)$$

It is observed that the performance of the converter is strongly affected by the value of β . The value of β in terms of the load parameters (i.e, θ , ϕ and Z) and α can be found as follows.

In the interval $\alpha \leq \omega t \leq \beta$

$$L \frac{di_o}{dt} + Ri_o + E = \sqrt{2}V_i \sin\omega t \quad (10.37)$$

$$i_o \Big|_{\omega t = \alpha} = 0$$

From which the solution of i_o can be written as

$$i_o = \frac{\sqrt{2}V_i}{Z} \left[\sin(\phi - \alpha) e^{-\frac{(\omega t - \alpha)}{\tan\phi}} - \frac{\sin\theta}{\cos\phi} \left\{ 1 - e^{-\frac{(\omega t - \alpha)}{\tan\phi}} \right\} + \sin(\omega t - \phi) \right] \quad (10.38)$$

$$\text{Now } i_o \Big|_{\omega t = \beta} = 0$$

$$\therefore \sin(\phi - \alpha) e^{\frac{\alpha - \beta}{\tan\phi}} - \frac{\sin\theta}{\cos\phi} \left[1 - e^{\frac{\alpha - \beta}{\tan\phi}} \right] + \sin(\beta - \phi) = 0 \quad (10.39)$$

Given ϕ , α and θ , the value of β can be found by solving equation 10.39.

10.3.3 Inverter Mode of operation

The expression for average dc voltage from a single phase fully controlled converter in continuous conduction mode was

$$V_0 = \frac{2\sqrt{2}}{\pi} V_i \cos\alpha \quad (10.40)$$

For $\alpha < \pi/2$, $V_d > 0$. Since the thyristors conducts current only in one direction $I_0 > 0$ always. Therefore power flowing to the dc side $P = V_0 I_0 > 0$ for $\alpha < \pi/2$. However for $\alpha > \pi/2$, $V_0 < 0$. Hence $P < 0$. This may be interpreted as the load side giving power back to the ac side and the converter in this case operate as a line commutated current source inverter. So it may be tempting to conclude that the same converter circuit may be operated as an inverter by just increasing α beyond $\pi/2$. This might have been true had it been possible to maintain continuous conduction for $\alpha < \pi/2$ without making any modification to the converter or load connection. To supply power, the load EMF source can be utilized. However the connection of this source in Fig 10.3 is such that it can only absorb power but can not supply it. In fact, if an attempt is made to supply power to the ac side (by making $\alpha > \pi/2$) the energy stored in the load inductor will be exhausted and the current will become discontinuous as shown in Fig 10.7 (a).

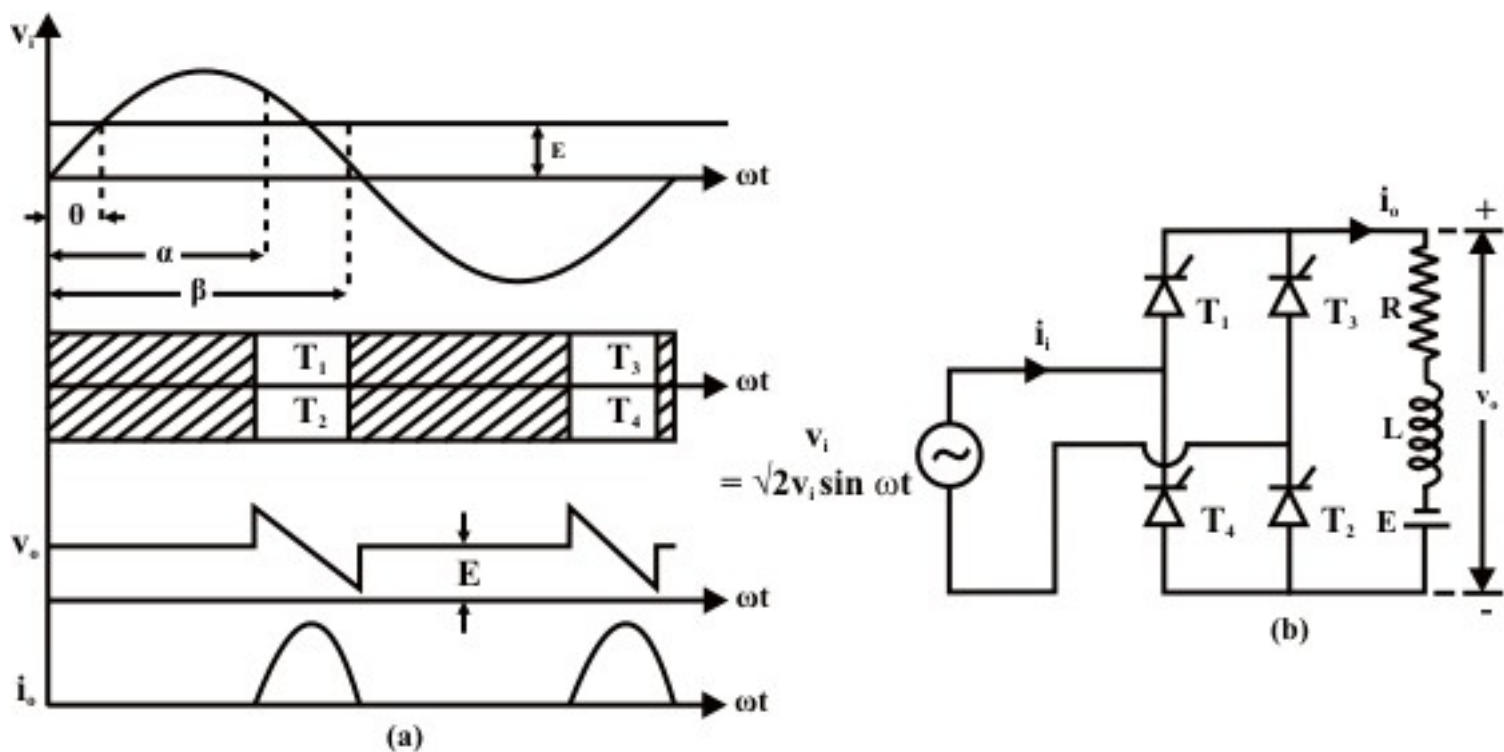

Fig. 10.7: Inverter mode of operation of single phase fully controlled converter
(a) Waveforms for $\alpha > \pi/2$ & $E > 0$
(b) Circuit connection in the inverter mode

Therefore for sustained inverter mode of operation the connection of E must be reversed as shown in Fig 10.7(b).

Fig 10.8 (a) and (b) below shows the waveforms of the inverter operating in continuous conduction mode and discontinuous conduction mode respectively. Analysis of the converter remains unaltered from the rectifier mode of operation provided θ is defined as shown.

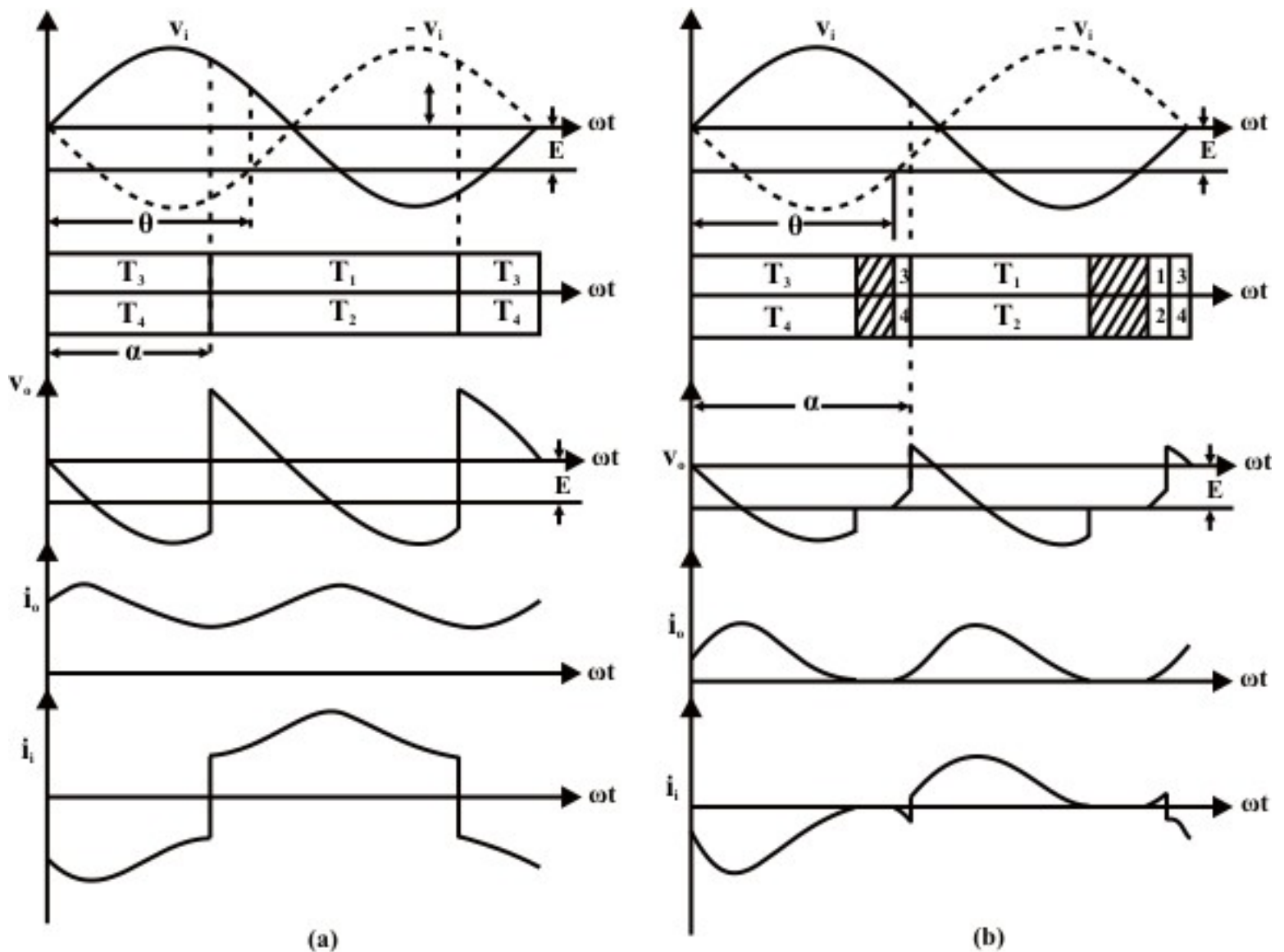

Fig. 10.8: Waveforms in the inverter mode of operation
(a) Continuous conduction;
(b) discontinuous conduction.

Exercise 10.3

Fill in the blank(s) with the appropriate word(s)

- i) In the discontinuous conduction mode the load current remains _____ for a part of the input cycle.
- ii) For the same firing angle the load voltage in the discontinuous conduction mode is _____ compared to the continuous conduction mode of operation.
- iii) The load current ripple factor in the continuous conduction mode is _____ compared to the discontinuous conduction mode.

- iv) In the inverter mode of operation electrical power flows from the _____ side to the _____ side.
- v) In the continuous conduction mode if the firing angle of the converter is increased beyond _____ degrees the converter operates in the _____ mode.

Answers: (i) zero; (ii) higher; (iii) lower; (iv) dc, ac; (v) 90, inverter.

2. A 220 V, 20A, 1500 RPM separately excited dc motor has an armature resistance of 0.75Ω and inductance of 50mH. The motor is supplied from a 230V, 50Hz, single phase supply through a fully controlled bridge converter. Find the no load speed of the motor and the speed of the motor at the boundary between continuous and discontinuous modes when $\alpha = 25^\circ$.

Answer: At no load the average motor torque and hence the average motor armature current is zero. However, since a converter carries only unidirectional current, zero average armature current implies that the armature current is zero at all time. From Fig 10.6(b) this situation can occur only when $\theta = \pi/2$, i.e the back emf is equal to the peak of the supply voltage. Therefore,

$$E_b|_{\text{no load}} = \sqrt{2} \times 230 \text{ V} = 325.27 \text{ V}, \text{ Under rated condition } E_b|_{1500} = 205 \text{ V}$$

$$\therefore N_{\text{no load}} = \frac{325.27}{205} \times 1500 = 2380 \text{ RPM}$$

At the boundary between continuous and discontinuous conduction modes from equation 10.32

$$\sin\theta = \cos\phi \sin(\phi - \alpha) \frac{1 + e^{-\pi/\tan\phi}}{1 - e^{-\pi/\tan\phi}}$$

From the given data $\phi = 87.27^\circ$, $\alpha = 25^\circ$

$$\therefore \sin\theta = 0.5632$$

$$\therefore E_b = \sqrt{2} V_i \sin\theta = 183.18 \text{ Volts}$$

$$\therefore \text{Motor speed } N = \frac{183.18}{205} \times 1500 = 1340 \text{ RPM.}$$

Summary

- Single phase fully controlled converters are obtained by replacing the diodes of an uncontrolled converter with thyristors.
- In a fully controlled converter the output voltage can be controlled by controlling the firing delay angle (α) of the thyristors.
- Single phase fully controlled half wave converters always operate in the discontinuous conduction mode.
- Half wave controlled converters usually have poorer output voltage form factor compared to uncontrolled converter.
- Single phase fully controlled bridge converters are extensively used for small dc motor drives.

- Depending on the load condition and the firing angle a fully controlled bridge converter can operate either in the continuous conduction mode or in the discontinuous conduction mode.
- In the continuous conduction mode the load voltage depends only on the firing angle and not on load parameters.
- In the discontinuous conduction mode the output voltage decreases with increasing load current. However the output voltage is always greater than that in the continuous conduction mode for the same firing angle.
- The fully controlled bridge converter can operate as an inverter provided (i) $\alpha > \frac{\pi}{2}$, (ii) a dc power source of suitable polarity exists on the load side.

References

- 1) “Power Electronics” P.C.Sen; Tata McGraw-Hill 1995
- 2) “Power Electronics; Circuits, Devices and Applications”, Second Edition, Muhammad H.Rashid; Prentice-Hall of India; 1994.
- 3) “Power Electronics; Converters, Applications and Design” Third Edition, Mohan, Undeland, Robbins, John Wileys and Sons Inc, 2003.

Practice Problems and Answers

- Q1. Is it possible to operate a single phase fully controlled half wave converter in the inverting mode? Explain.
- Q2. A 220V, 20A 1500 RPM separately excited dc motor has an armature resistance of 0.75Ω and inductance of 50 mH. The motor is supplied from a single phase fully controlled converter operating from a 230 V, 50 Hz, single phase supply with a firing angle of $\alpha = 30^\circ$. At what speed the motor will supply full load torque. Will the conduction be continuous under this condition?
- Q3. The speed of the dc motor in question Q2 is controlled by varying the firing angle of the converter while the load torque is maintained constant at the rated value. Find the “power factor” of the converter as a function of the motor speed. Assume continuous conduction and ripple free armature current.
- Q4. Find the load torque at which the dc motor of Q2 will operate at 2000 RPM with the field current and α remaining same.
- Q5. A separately excited dc motor is being braked by a single phase fully controlled bridge converter operating in the inverter mode as shown in Fig 10.7 (b). Explain what will happen if a commutation failure occurs in any one of the thyristors.

Answers

- As explained in section 10.3.3, the load circuit must contain a voltage source of proper polarity. Such a load circuit and the associated waveforms are shown in the figure next.

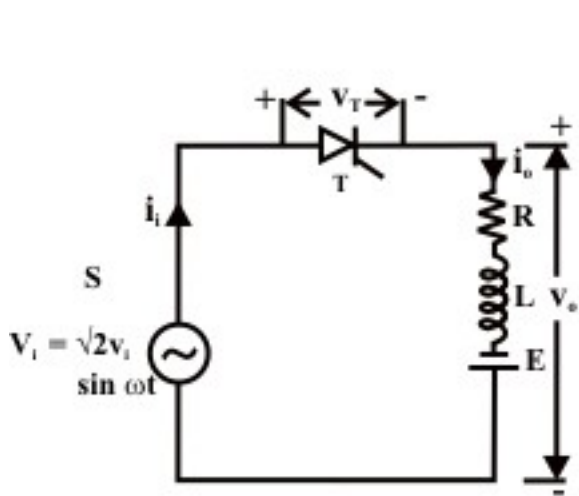

Fig. PPM1 (a)

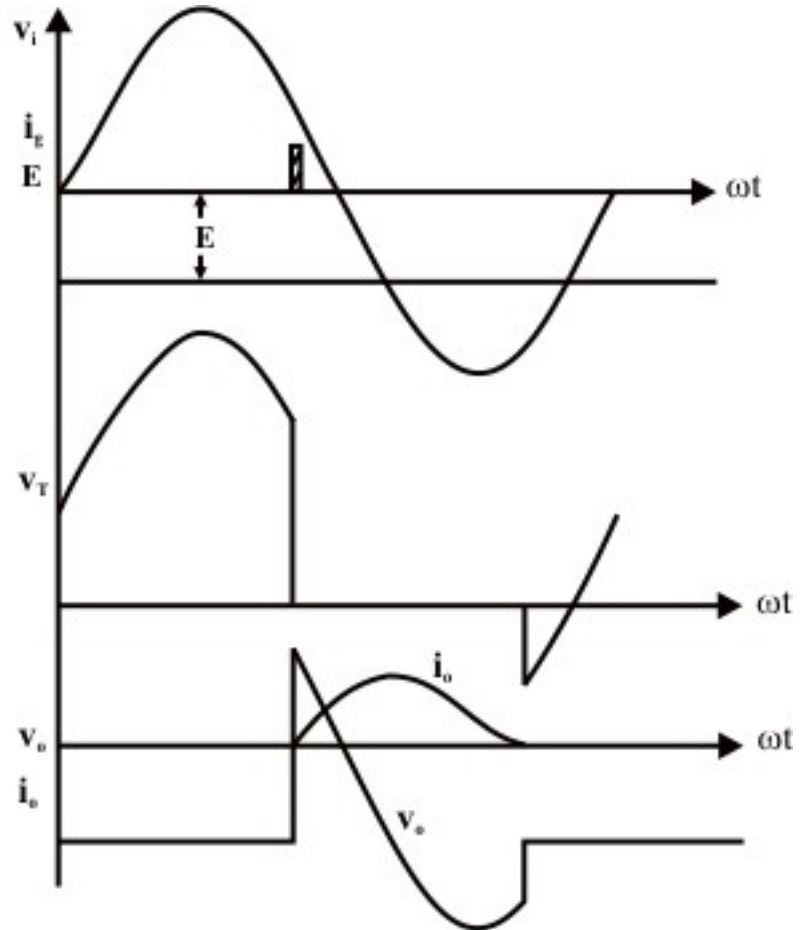

Fig. PPM1(b)

Figure shows that it is indeed possible for the half wave converter to operate in the inverting mode for some values of the firing angle. However, care should be taken such that i_o becomes zero before v_i exceeds E in the negative half cycle. Otherwise i_o will start increasing again and the thyristor T will fail to commutate.

- For the machine to deliver full load torque with rated field the armature current should be 20 Amps.

$$\text{Assuming continuous conduction } v_o = \frac{2\sqrt{2} \times 230}{\pi} \cos 30^\circ = 179.33 \text{ volts.}$$

For 20 Amps armature current to flow the back emf will be

$$E_b = V_a - I_a R_a = 179.33 - 20 \times 0.75 = 164.33 \text{ volts}$$

$$\therefore \sin \theta = \frac{E_b}{\sqrt{2} V_i} = 0.505.$$

For the given machine, $\tan\phi = \frac{\omega L_a}{R_a} = 20.944$, $\phi = 87.266^\circ$.

Now from equation (10.32)

$$\frac{2\sin(\phi - \alpha)}{1 - e^{-\pi/\tan\phi}} - \sin(\phi - \alpha) = 11.2369.$$

$$\text{and } \frac{\sin\theta}{\cos\phi} = 10.589$$

\therefore the conduction is continuous.

At 1500 RPM the back emf is $220 - 20 \times 0.75 = 205$ volts.

\therefore The speed at which the machine delivers rated torques

$$\text{is } N_r = \frac{164.33}{205} \times 1500 = 1202 \text{ RPM.}$$

3. To maintain constant load torque equal to the rated value the armature voltage should be

$$\begin{aligned} V_a &= r_a I_a \Big|_{\text{rated}} + E_b \Big|_{\text{rated}} \frac{N}{N_{\text{rated}}} \\ &= 0.75 \times 20 + 205 \times \frac{N}{1500} = 0.137 N + 15 \text{ V} \end{aligned}$$

In a fully controlled converter operating in the continuous conduction mode

$$V_a = \frac{2\sqrt{2}}{\pi} V_i \cos\alpha = 207.073 \cos\alpha$$

$$\therefore \cos\alpha = 6.616 \times 10^{-4} N + 0.0724$$

Now the power factor from equation 10.31 is

$$\text{pf} = \frac{2\sqrt{2}}{\pi} \cos\alpha = 5.9565 \times 10^{-4} N + 0.0652$$

This gives the input power factor as a function of speed.

4. At 2000 RPM, $E_b = \frac{2000}{1500} \times 205 = 273.33$ volts

$$\therefore \sin\theta = \frac{E_b}{\sqrt{2}V_i} = 0.84, \quad \phi = 87.266^\circ, \quad \alpha = 30^\circ$$

From equation 10.32 it can be shown that the conduction will be discontinuous.

Now from equation 10.39

$$\sin[(\alpha - \phi) - (\alpha - \beta)] + e^{\frac{\alpha - \beta}{\tan\phi}} \left[\frac{\sin\theta}{\cos\phi} + \sin(\phi - \alpha) \right] = \frac{\sin\theta}{\cos\phi}$$

$$\text{or } e^{0.477(\alpha - \beta)} [17.61 + 0.8412] - \sin[57.266^\circ + (\alpha - \beta)] = 17.61$$

$$18.4515 e^{0.477(\alpha - \beta)} - \sin[(\alpha - \beta) + 57.266^\circ] = 17.61$$

Solving which $\beta \approx 140^\circ$

∴ from equation 10.36

$$I_{\text{Oav}} = \frac{\sqrt{2}V_i}{\pi Z \cos\phi} [\cos\alpha - \cos\beta + \sin\theta(\alpha - \beta)] = 2.676 \text{ Amps}$$

∴ the load torque should be $\frac{2.676}{20} \times 100 = 13.38\%$ of the full load torque.

5. Referring to Fig 10.8 (a) let there be a commutation failure of T_1 at $\omega t = \alpha$. In that case the conduction mode will be $T_3 T_2$ instead of $T_1 T_2$ and v_0 will be zero during that period. As a result average value of V_0 will be less negative and the average armature current will increase. However the converter will continue to operate in the inverter mode and the motor will be braked.

Source:[http://www.nptel.ac.in/courses/Webcourse-contents/IIT%20Kharagpur/Power%20Electronics/PDF/L-10\(DK\)\(PE\)%20\(\(EE\)NPTEL\).pdf](http://www.nptel.ac.in/courses/Webcourse-contents/IIT%20Kharagpur/Power%20Electronics/PDF/L-10(DK)(PE)%20((EE)NPTEL).pdf)