

Module 7 Transformer

Version 2 EE IIT, Kharagpur

Lesson 28

Problem solving on Transformers

Contents

| | | |
|-----------|---|----------|
| 28 | Problem solving on Transformer (Lesson-28) | 4 |
| 28.1 | Introduction | 4 |
| 28.2 | Problems on 2 winding single phase transformers | 4 |
| 28.3 | Problems on 3-phase ideal transformer | 10 |
| 28.4 | Problems on ideal auto transformers | 14 |

28.1 Introduction

In this lesson some typical problems on transformer are solved with emphasis on logical steps involved. For a practical two winding transformer, the knowledge of approximate equivalent circuit is of utmost importance in order to predict its performance. Equivalent circuit parameters are either supplied directly or indirectly in terms of O.C and S.C test data. The first problem enumerates in detail how to get the equivalent circuit parameters from test data. The importance of the side (LV or HV) in which calculations are carried out is highlighted. The second problem, in fact, is an extension of the first problem. Calculation of regulation, efficiency and maximum efficiency are dealt with in these problems.

Next few problems highlight the basic calculation steps involved in *ideal* 3-phase transformer and *ideal* auto transformer since the equivalent circuit of these transformers are outside the scope of first year electrical technology course.

28.2 Problems on 2 winding single phase transformers

1. The O.C and S.C test data are given below for a single phase, 5 kVA, 200V/400V, 50Hz transformer.

| | | | |
|-------------------------|------|-------|------|
| O.C test from LV side : | 200V | 1.25A | 150W |
| S.C test from HV side : | 20VV | 12.5A | 175W |

Draw the equivalent circuit of the transformer (i) referred to LV side and (ii) referred to HV side inserting all the parameter values.

Solution

Let us represent LV side parameters with suffix 1 and HV side parameters with suffix 2.

Computation with O.C test data

Let us show the test data in the approximate equivalent circuit (Figure 28.1) of the transformer as given below.

Due to the fact that the HV side is open circuited, there will be no current in the branch $r_{e1} + jx_{e1}$. So entire power of 150W is practically dissipated in R_{c11} . The no load current $I_{01} = 1.25 A$ is divided into: magnetizing component I_{m1} and core loss component I_{c11} as depicted in the phasor diagram figure 28.1.

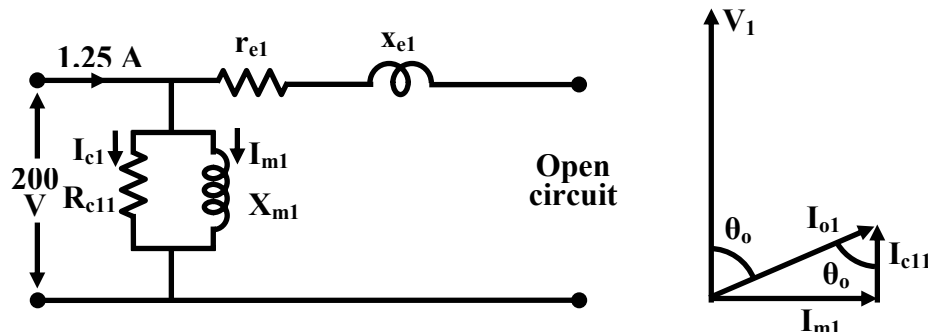

Figure 28.1: O.C equivalent circuit and phasor diagram.

$$\begin{aligned}
\text{No load (or O.C) power factor } \cos \theta_o &= \frac{150}{200 \times 1.25} \\
&= 0.6 \\
\therefore \theta_o &= \cos^{-1} 0.6 \\
&= 53.13^\circ \\
\text{Hence, } \sin \theta_o &= 0.8
\end{aligned}$$

After knowing the value of $\cos \theta_o$ and $\sin \theta_o$ and referring to the no load phasor diagram, I_{m1} and I_{cl1} can be easily calculated as follows.

$$\begin{aligned}
\text{Magnetizing component } I_{m1} &= I_{01} \sin \theta_o \\
&= 1.25 \times 0.8 \\
\therefore I_{m1} &= 1A \\
\text{core loss component, } I_{cl1} &= I_{01} \cos \theta_o \\
&= 1.25 \times 0.6 \\
\therefore I_{cl1} &= 0.75A
\end{aligned}$$

Thus the parallel branch parameters X_{m1} and R_{cl1} can be calculated.

$$\begin{aligned}
\text{Magnetizing reactance } X_{m1} &= \frac{V_1}{I_{m1}} \\
&= \frac{200}{1} \\
\therefore X_{m1} &= 200\Omega \\
\text{Resistance representing core loss } R_{cl1} &= \frac{V_1}{I_{cl1}} \\
&= \frac{200}{0.75} \\
\therefore R_{cl1} &= 266.67\Omega
\end{aligned}$$

It may be noted that from the O.C test data we can get the parallel branch impedances namely the *magnetizing reactance* and the *resistance representing the core loss* referred to the side where measurements have been taken.

Computation with S.C test data

Since the test has been carried out from the HV side with LV side shorted, we draw the equivalent circuit referred to the HV side as shown in figure 28.2. Parameter values are denoted by using suffix 2. Important point to note here is the absence of the parallel branch. The reason

being, the voltage applied during S.C test is quite low causing a low flux level. Hence magnetizing and core loss component of currents will be pretty small compared to the rated current flowing through $r_{e2} + jx_{e2}$. In this case, power drawn from the supply gets practically dissipated in winding resistances i.e., r_{e2} .

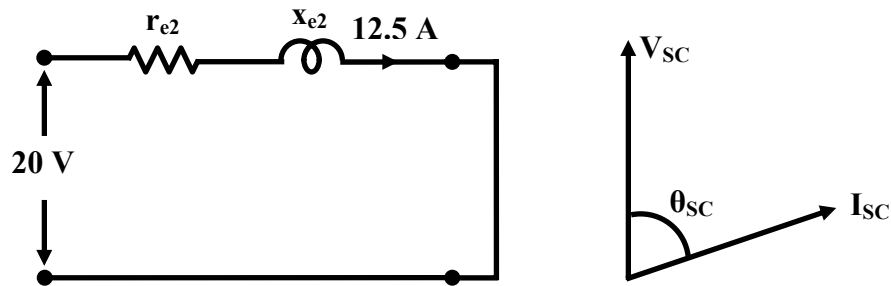

Figure 28.2: O.C equivalent circuit and phasor diagram.

Calculation of series parameters is rather simple and as follows.

$$\text{Power drawn } W_{sc} = I_{sc}^2 r_{e2}$$

$$\begin{aligned} \text{or, } r_{e2} &= \frac{W_{sc}}{I_{sc}^2} \\ &= \frac{175}{12.5^2} \end{aligned}$$

$$\therefore r_{e2} = 1.12\Omega$$

$$\begin{aligned} \text{Now S.C impedance } z_{sc} &= \frac{V_{sc}}{I_{sc}} \\ &= 20/12.5 \end{aligned}$$

$$\therefore z_{sc} = 1.6\Omega = \sqrt{r_{e2}^2 + x_{e2}^2}$$

$$\begin{aligned} \text{Thus, } x_{e2} &= \sqrt{z_{sc}^2 - r_{e2}^2} \\ &= \sqrt{1.6^2 - 1.12^2} \end{aligned}$$

$$\therefore x_{e2} = 1.14\Omega$$

Although calculation of parameters from the test results are over, it is *very important* to note that parallel branch parameters have been obtained referred to LV side and series branch parameters have been obtained referred to HV side. However to draw a meaningful equivalent circuit referred to a particular side, *all the parameters are to be represented/calculated referred to that side.*

Equivalent circuit referred LV side

The parallel branch parameters $R_{c1} = 266.67\Omega$ and $X_{m1} = 200\Omega$ have already been calculated wrt LV side. Naturally no further transformations are necessary. However, series parameters r_{e2} and x_{e2} have been calculated above from test data. So we need to calculate r_{e1} and x_{e1} in order to correctly represent the equivalent circuit referred to primary side.

$$\begin{aligned}\text{Turns ratio, } a &= 200/400 = 0.5 \\ \text{but we know, } r_{e1} &= a^2 r_{e2} \\ \text{and } x_{e1} &= a^2 x_{e2} \\ \text{Thus } r_{e1} &= 0.5^2 \times 1.12 = 0.28\Omega \\ \text{and } x_{e1} &= 0.5^2 \times 1.14 = 0.285\Omega\end{aligned}$$

So the equivalent circuit referred to LV side can now be drawn showing all the parameter values as shown below in figure 28.3.

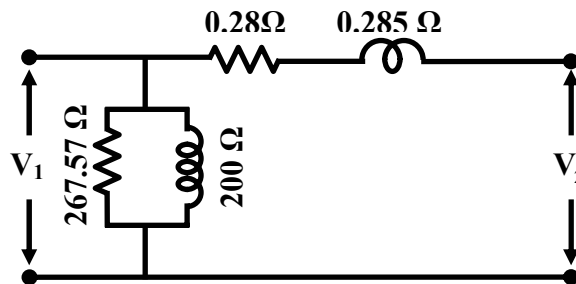

Figure 28.3: Equivalent circuit referred to LV side.

Equivalent circuit referred HV side

Here we note that series parameters referred to HV side are already known to be $r_{e2} = 1.12\Omega$ and $x_{e2} = 1.14\Omega$. However, the parallel branch parameters are to be transformed as follows.

$$\begin{aligned}\text{Turns ratio, } a &= 0.5 \\ \text{but we know, } R_{c2} &= R_{c1}/a^2 \\ \text{and } X_{m2} &= X_{m1}/a^2 \\ \text{Thus, } R_{c2} &= 266.67/0.5^2 = 1066.68\Omega \\ \text{and } X_{m2} &= 200/0.5^2 = 800\Omega\end{aligned}$$

We are now in a position to draw the equivalent circuit of the same transformer referred to the HV side as shown in figure 28.4.

After getting the equivalent circuit, regulation, efficiency of the transformer can be predicted under various loading conditions. Solution of the next problem shows how equivalent circuit can be used to predict the performance,

2. For the same transformer (single phase, 5 kVA, 200V/400V, 50 Hz) of problem 1, the equivalent circuit of which is known, calculate the following:
- the efficiency of the transformer at 75% loading with load power factor = 0.7

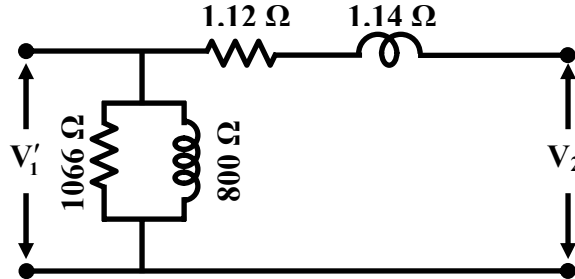

Figure 28.4: Equivalent circuit referred to HV side.

- At what load or kVA the transformer is to be operated for maximum efficiency? Also calculate the value of maximum efficiency.
- The regulation of the transformer at full load 0.8 power factor lag.
- What should be the applied voltage to the LV side when the transformer delivers rated current at 0.7 power factor lagging, at a terminal voltage of 400 V?

Solution

- From the test data of the previous problem, we have:

$$\text{Full load kVA rating, } S = 5 \text{ kVA}$$

$$\text{Core loss at rated voltage \& frequency, } P_{core} = 150 \text{ W}$$

$$\text{Full load copper loss, } P_{cu} = 175 \text{ W}$$

$$\text{We know, efficiency, } \eta = \frac{x S \cos \theta}{x S \cos \theta + P_{core} + x^2 P_{cu}}$$

$$75\% \text{ loading means, } x = 0.75$$

$$\text{load power factor, } \cos \theta = 0.7$$

$$\begin{aligned} \therefore \eta &= \frac{0.75 \times 5000 \times 0.7}{0.75 \times 5000 \times 0.7 + 150 + 0.75^2 \times 175} \\ &= 2625/2873.44 \end{aligned}$$

$$\therefore \% \text{ efficiency, } \eta = 91.35\%$$

- We know maximum efficiency occurs when $x^2 P_{cu} = P_{core}$, where P_{cu} is the full load copper loss and P_{core} is the iron loss. Now $P_{cu} = 175 \text{ W}$ and $P_{core} = 120 \text{ W}$.

$$\text{Per unit value of loading for } \eta_{max} \text{ is } x = \sqrt{P_{core}/P_{cu}}$$

$$= \sqrt{120/175}$$

$$\therefore x = 0.83$$

$$\begin{aligned} \text{Thus the load for } \eta_{max} &= x S \\ &= 0.83 \times 5\text{kVA} \end{aligned}$$

$$\therefore \text{the required load for } \eta_{max} = 4.15\text{kVA}$$

- iii. To calculate the regulation of the transformer at load current I_2 and load power factor $\cos \theta$, we use the following formula in terms of HV side parameters.

$$\text{Per unit regulation, } R = \frac{I_2 r_{e2} \cos \theta + I_2 x_{e2} \sin \theta}{V_{20}}$$

$$\text{Putting the values, } R = \frac{12.5 \times 1.12 \times 0.7 + 12.5 \times 1.14 \times 0.71}{400}$$

$$\therefore \% \text{ regulation, } R = 4.9\%$$

- iv. It is interesting to note that the difference between the reflected primary supply voltage magnitude V_1' and the secondary load terminal voltage magnitude V_2 is the numerator of the regulation formula used above.

$$V_1' - V_2 = I_2 r_{e2} \cos \theta + I_2 x_{e2} \sin \theta$$

$$\begin{aligned} \text{or, } V_1' &= V_2 + I_2 r_{e2} \cos \theta + I_2 x_{e2} \sin \theta \\ &= 12.5 \times 1.12 \times 0.7 + 12.5 \times 1.14 \times 0.71 \\ &= 400 + 19.92\text{V} \end{aligned}$$

$$\text{so, } V_1' = 419.92\text{V}$$

Remember V_1' represents the applied voltage to LV calculated in terms of HV side. So the magnitude of the actual voltage to be applied across the primary is:

$$\begin{aligned} V_1 &= a V_1' \\ &= 0.5 \times 419.92 \\ \therefore V_1 &= 210 \text{ V} \end{aligned}$$

28.3 Problems on 3-phase ideal transformer

It may be recalled that one can make a 3-phase transformer by using a bank of three numbers of identical single phase transformers or a single unit of a 3-phase transformers.

1. Three single phase *ideal* transformers, each of rating 5kVA, 200V/400V, 50 Hz are available.
 - a) The LV sides are connected in star and HV sides are connected in delta. What line to line 3-phase voltage should be applied and what will be the corresponding HV side line to line voltage will be? Also calculate and show the line and phase current magnitudes in both LV & HV sides corresponding to rated condition.
 - b) The LV sides are connected in delta and HV sides are connected in delta. What line to line 3-phase voltage should be applied and what will be the corresponding HV side line to line voltage will be? Also calculate and show the line and phase current magnitudes in both LV & HV sides corresponding to rated condition.

Solution

Here the idea is not to exceed the voltage and current rating of HV and LV coils of each single phase transformer. Now for each transformer having rating 5 kVA, 200V/100V, 50 Hz we have:

$$\text{Rated voltage of each HV coil is} = 200\text{V}$$

$$\text{Rated voltage of each LV coil is} = 100\text{V}$$

$$\text{Phase turns ratio is } a_{ph} = 200/100 = 2$$

$$\text{Rated current of each HV coil is} = 5000/200 = 25\text{A}$$

$$\text{Rated current of each LV coil is} = 5000/100 = 50\text{A}$$

Solution of (a)

In this case HV sides are connected in star and LV sides are connected in delta as shown in figure 28.5. Thus line to line voltage to be applied to HV side must not exceed $200\sqrt{3} = 346.4\text{V}$. This will ensure that rated voltage is applied across each of the HV coil and rated voltage of 100 V is induced in each of the LV coil. Obviously the available line to line voltage on the LV side will be 100 V since the coils on this side are connected in delta.

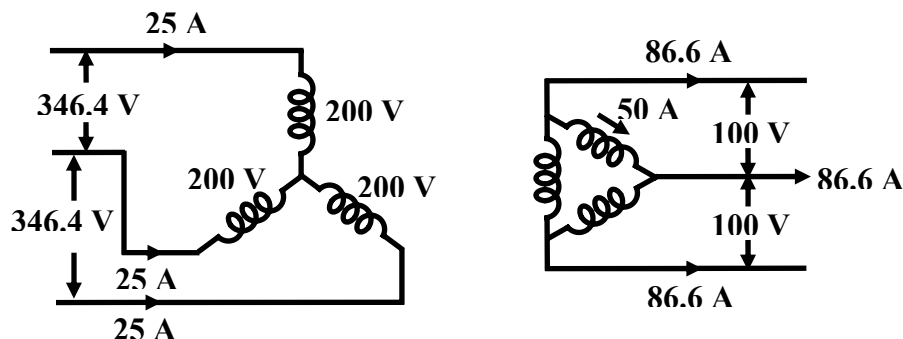

Figure 28.5: Connection of transformers for part (a).

Now the question is how much line current should be allowed to be supplied by the LV side when balanced 3-phase load is connected across it? The constrain is that we should not allow overloading of any of the coils in terms of current as well. Since rated current of each LV side coil is 50 A and the coils are connected in delta, so the corresponding allowed line current in the LV side will be $50\sqrt{3} = 86.6A$ (Note: line current = $\sqrt{3}$ phase current in delta connection).

But we know for any individual ideal transformer if LV coil carries a 50 A current, the corresponding HV coil must carry a current of $50/a_{ph} = 25$ A as shown in fig 28.5. Thus HV side line current drawn from the supply must be also 25 A as these coils are connected in star (Note: line current = phase current in star connection).

Now we are in a position to calculate the total kVA handled by the bank of 3-phase transformer. Referring to the LV side the transformers supplies 86.6 A line current at a line to line voltage of 100 V. Therefore, total kVA supplied is equal to $\sqrt{3} V_{LL} I_L = \sqrt{3} \times 100 \times 86.6 \text{ VA} = 15 \text{ kVA}$. Similarly total kVA drawn from the supply is calculated as $\sqrt{3} \times 346.4 \times 25 \text{ mbox VA} = 15 \text{ kVA}$. Thus we see the total kVA becomes 3 times the individual kVA rating of the transformers. Since the transformers are assumed to be ideal *Total kVA input = Total kVA output*.

Solution of (b)

In this case HV sides are connected in delta and LV sides are connected in star as shown in figure 28.6. Thus line to line voltage to be applied to HV side must not exceed 200V. This will ensure that rated voltage is applied across each of the HV coil and rated voltage of 100 V is induced in each of the LV coils. The available line to line voltage on the LV side will be $100 \sqrt{3} = 173.2 \text{ V}$ since coils on this side are connected in star.

Since LV coils are connected in star allowed line current to be delivered is 50 A. So total kVA output is $\sqrt{3} \times 173.2 \times 50 \text{ VA} = 15 \text{ kVA}$. In each HV coil current has to be 25 A and the corresponding supply line current is $\sqrt{3} \times 25 = 43.3A$. Total input kVA is $\sqrt{3} \times 200 \times 43.3 \text{ VA} = 15 \text{ kVA}$. Distribution of phase and line currents in LV and HV sides are shown in figure 28.6.

2. Three identical single phase transformers each of rating 5 kVA, 200V/100V, 50Hz are connected in delta-delta. Calculate what line to line voltage to be applied to the HV side? Also find out corresponding LV side line to line voltage. Find out the kVA rating of the bank such that none of the transformers get over loaded.

Solution

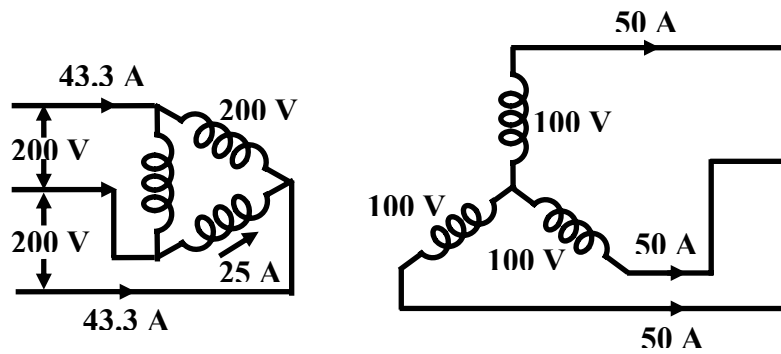

Figure 28.6: Connection of transformers for part (b).

The connection diagram of the delta-delta arrangement is shown in figure 28.7

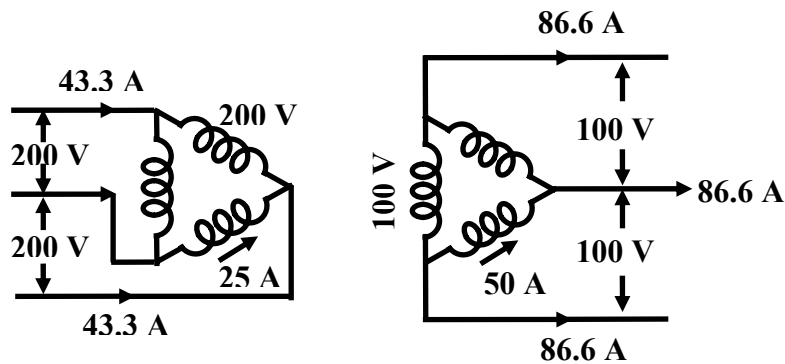

Figure 28.7: Connection of transformers for delta-delta.

As explained in the first two problems, line to line voltage to be applied to the HV side is 200 V because of delta connection. Induced voltage in each coil has to be 100 V in the LV side. Since the LV coils are also connected in delta the line to line voltage on the LV side is 100 V. Since coil current has to be rated values, line currents on HV and LV sides are obtained as 43.3 A and 86.6 A. Total kVA that can be handled by the bank is $\sqrt{3} \times 200 \times 43.3 \text{ VA} = \sqrt{3} \times 100 \times 86.6 \text{ VA} = 15 \text{ kVA}$.

- Two identical transformers each of rating 5 kVA, 200V/100V, 50 Hz transformers are connected in *open delta*. Calculate the kVA rating of the open delta bank when HV side is used as primary.

Solution: The relevant connection for open delta is shown in figure 28.8

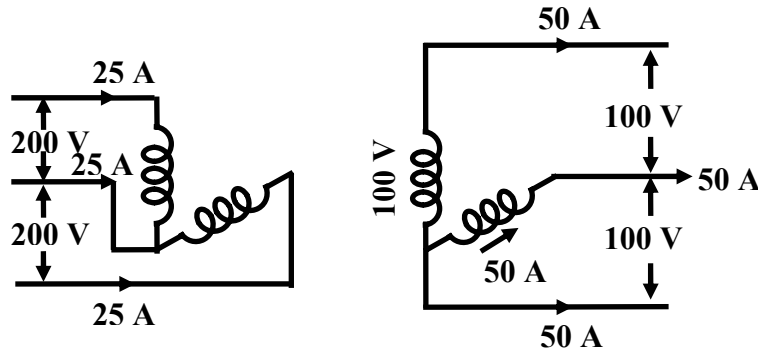

Figure 28.8: Connection of transformers for open delta.

In open delta connection each coil is connected across the lines; therefore, the line to line voltage to be applied to the HV side is 200 V. Induced voltage in the LV coils will be 100 V. Hence line to line voltage in the LV side is 100 V.

A careful look at the circuit in fig 28.8 shows that both HV and LV coils are in series with the lines. Thus if we want the transformers not to be over loaded, line currents on the LV side must be 50 A which automatically fixes the HV side line current to be 25 A.

Let us use $\sqrt{3} V_{LL} I_L$ to calculate the kVA handled by the bank of two single phase transformers i.e;

$$\text{Total kVA} = \sqrt{3} \times 100 \times 50 = \sqrt{3} \times 200 \times 25 \text{ VA} = 8.66 \text{ kVA}$$

It is interesting to note that in other types of 3-phase connection of transformers such as star-star, star-delta, delta-delta, total kVA handled without overloading any of the transformers is 3 times the individual rating of the transformers. This we learned while solving previous problems where we got the total kVA as 15 kVA ($= 3 \times 5 \text{ kVA}$). But in open delta connection where two single phase identical transformers each of rating 5 kVA has been employed we note the total kVA handled is **not** 10 kVA ($= 2 \times 5$)kVA but 8.66 kVA only. Thus total kVA available as open delta is only $\frac{8.66}{10} \times 100 = 86.6\%$ of the installed capacity.

4. A 3-phase, 500 kVA, 6000V/400V, 50Hz, delta-star connected transformer is delivering 300 kW, at 0.8 pf lagging to a balanced 3-phase load connected to the LV side with HV side supplied from 6000 V, 3- phase supply. Calculate the line and winding currents in both the sides. Assume the transformer to be ideal.

Solution

First note that it is not a bank of single phase transformers. In fact it is a single unit of 3-phase transformer with the name plate rating as 500 kVA, 6000 V/400 V, 50Hz, delta-star connected 3-phase transformer. 500 kVA represents the *total* kVA and voltages specified are always line to line. Similarly unless otherwise specified, kW rating of a 3-phase load is the total kW absorbed by the load. The connection diagram is shown in figure 28.9.

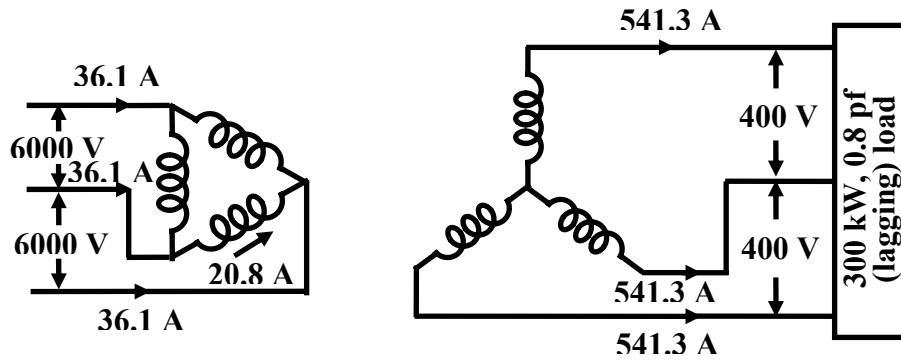

Figure 28.9: Connection diagram with 3-phase load.

Noting the relation kVA, $S = P / \cos \theta$ and $I = S / \sqrt{3} V_{LL}$ let us start out calculation.

$$\text{Load kVA} = 300/0.8 = 375 \text{ kVA} = \text{input kVA}$$

$$\text{Line current drawn by the load, } I_{2L} = 375000 / \sqrt{3} \times 400$$

$$I_{2L} = 541.3 \text{ A}$$

$$\text{Because of star connection, LV coil current} = 541.3 \text{ A}$$

$$\text{since input kVA} = 375 \text{ kVA}$$

$$\text{HV side line current, } I_{1L} = \frac{375000}{\sqrt{3} \times 6000}$$

$$\therefore I_{1L} = 36.1 \text{ A}$$

Actual phase winding currents can also be calculated as:

$$\text{LV side phase coil current} = \text{LV side line current}$$

$$\text{or, } I_{2ph} = I_{2L}$$

$$\therefore I_{2ph} = 541.3 \text{ A due to star connection.}$$

$$\text{HV side phase coil current} = \text{LV side line current} / \sqrt{3}$$

$$\text{or, } I_{1ph} = I_{1L} / \sqrt{3}$$

$$\therefore I_{1ph} = 36.1 / \sqrt{3} = 20.8 \text{ A due to delta connection.}$$

28.4 Problems on ideal auto transformers

Recall that an auto transformer essentially is essentially a single winding transformer with a portion of the winding common to both supply and the load side. In contrast to a two winding transformer it can not provide isolation between HV and LV side. Here VA is transferred from one side to the other not only by magnetic coupling but also by electrical conduction. Autotransformer becomes cheaper than a similarly rated two winding transformer when the voltage transformation ratio is close to unity. A single phase two winding transformer can be suitably connected to perform like an auto transformer.

1. A 5kVA, 200 V/ 100 V, 50 Hz, single phase ideal two winding transformer is to be used to step up a voltage of 200 V to 300 V by connecting it like an auto transformer. Show the connection diagram to achieve this. Calculate the maximum kVA that can be handled by the autotransformer (without over loading any of the HV and LV coil). How much of this kVA is transferred magnetically and how much is transferred by electrical conduction.

Solution

To connect a two winding transformer as an auto transformer, it is essential to know the dot markings on the two coils. The coils are to be now series connected appropriately so as to identify clearly between which two terminals to give supply and between which two to connect the load. Since the input voltage here is 200 V, supply must be connected across the HV terminals. The induced voltage in the LV side in turn gets fixed to 100 V. But we require 300 V as output, so LV coil is to be connected in additive series with the HV coil. This is what has been shown in figure 28.10.

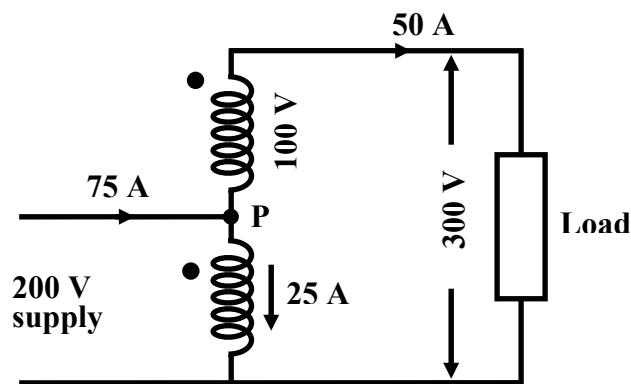

Figure 28.10: Two winding transformer as an autotransformer.

Here the idea is not to exceed the voltage and current rating of HV and LV coils of the two winding transformer. Now for the transformer having rating 5 kVA, 200 V/ 100 V, 50 Hz we have:

$$\text{Rated voltage of HV coil is} = 200 \text{ V}$$

$$\text{Rated voltage of LV coil is} = 100 \text{ V}$$

$$\text{Phase turns ratio is } a = 200/100 = 2$$

$$\text{Rated current of each HV coil is} = 5000/200 = 25 \text{ A}$$

$$\text{Rated current of each LV coil is} = 5000/100 = 50 \text{ A}$$

Since the load is in series with LV coil, so load current is same as the current flowing through the LV coil. Thus a maximum of 50 A can be drawn by the load otherwise overloading of the coils take place.

$$\text{Output kVA} = 300 \times 50 \text{ VA} = 15 \text{ kVA}$$

$$\text{input kVA} = \text{Output kVA} = 15 \text{ kVA}$$

\therefore transformer is ideal

$$\text{Current drawn from the supply} = 15000/200 = 75 \text{ A}$$

Now the question is how much current is flowing in the HV coil and in which direction? However, this is quite easy since supply and load currents are already known along with their directions as shown in figure 28.10. Applying KCL at the junction P, we get:

$$\text{Current through HV coil } I_{HV} = 75 - 50 = 25 \text{ A}$$

The direction of I_{HV} is obviously from top to bottom. No matter whether a two winding transformer is used as a two winding transformer or as an autotransformer, mmf must be balanced in the coils. If current comes out through the dot terminal in the LV coil, current must flow in through the dot of the HV coil.

It is important to note that as a two winding transformer, kVA handling capacity is 5 kVA, the rating of the transformer. However, the same transformer when connected as auto transformer, kVA handling capacity becomes 15 kVA without overloading any of the coils.

$$\begin{aligned} \text{kVA transferred magnetically} &= \text{kVA of either HV or LV coil} \\ &= 200 \times 25 \text{ VA} = 100 \times 50 \text{ VA} = 5 \text{ kVA} \\ \therefore \text{kVA transferred magnetically} &= 5 \text{ kVA} \\ \text{kVA transferred electrically} &= \text{total kVA transferred} - \text{kVA} \\ &\quad \text{transferred magnetically} \\ &= 15 - 5 = 10 \text{ kVA} \end{aligned}$$

- An autotransformer has a coil with total number of turns $N_{CD} = 200$ between terminals C and D. It has got one tapping at A such that $N_{AC} = 100$ and another tapping at B such that $N_{BA} = 50$. Calculate currents in various parts of the circuit and show their directions when 400 V supply is connected across AC and two resistive loads of 60Ω & 40Ω are connected across BC and DC respectively.

Solution

Let us first draw the circuit diagram (shown in figure 28.11) as per data given in the problem. First let us calculate the voltages applied across the loads remembering the fact that voltage per turn in a transformer remains constant.

$$\begin{aligned} \text{Supply voltage across AC, } V_{AC} &= 400\text{V} \\ \text{Number of turns between A \& C } N_{AC} &= 100 \\ \text{Voltage per turn} &= 400/100 = 4\text{V} \\ \text{Voltage across the } 40\Omega \text{ load} &= N_{DC} \times \text{Voltage per turn} \\ &= 200 \times 4 = 800\text{V} \\ \text{So, current through } 40\Omega &= 800/40 = 20\text{A} \\ \text{Voltage across the } 60\Omega \text{ load} &= N_{BC} \times \text{Voltage per turn} \end{aligned}$$

$$= 150 \times 4 = 600 \text{ V}$$

$$\text{So, current through } 60\Omega = 600/60 = 10\text{A}$$

(28.1)

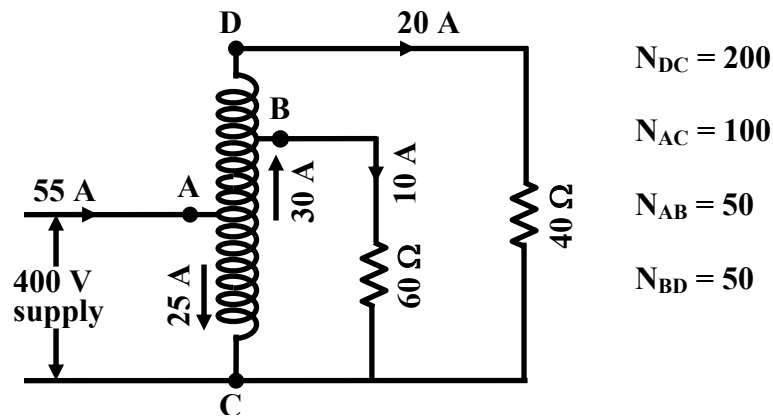

Figure 28.11: Circuit arrangement.

Total output kVA will be the simple addition of the kVAs supplied to the loads i.e.,

$$(600 \times 10 + 800 \times 20) \text{ VA} = 22000 \text{ VA} = 22 \text{ kVA}$$

Assuming the autotransformer to be ideal, input kVA must also be 22 kVA. We are therefore in a position to calculate the current drawn from the supply.

$$\text{Current drawn from the supply} = 22000/400 = 55 \text{ A}$$

Now we know all the load currents and the current drawn from the supply. Current calculations in different parts of the transformer winding becomes pretty simple-one has to apply KCL at the tap points B and A.

$$\text{Current in DB part of the winding } I_{BD} = 20 \text{ A}$$

$$\text{Applying KCL at B, current in AB part } I_{AB} = 20 + 10 = 30 \text{ A}$$

$$\text{Applying KCL at A, current in AC part } I_{AC} = 55 - 30 = 25 \text{ A}$$

It is suggested to repeat the problem if 40Ω resistor is replaced by an impedance $(30 + j40) \Omega$ other things remaining unchanged.

Source:[http://www.nptel.ac.in/courses/Webcourse-contents/IIT%20Kharagpur/Basic%20Electrical%20Technology/pdf/L-28\(TB\)\(ET\)%20\(\(EE\)NPTEL\).pdf](http://www.nptel.ac.in/courses/Webcourse-contents/IIT%20Kharagpur/Basic%20Electrical%20Technology/pdf/L-28(TB)(ET)%20((EE)NPTEL).pdf)