

HIGH FREQUENCY BOOST CONVERTER EMPLOYING SOFT SWITCHING AUXILIARY RESONANT CIRCUIT

¹G. NARESH GOUD, ²Y.LAKSHMI DEEPA, ³G.DILLI BABU, ⁴P.RAJASEKHAR & ⁵N.GANGADHER

Abstract - A new soft-switching boost converter is proposed in this paper. The conventional boost converter generates switching losses at turn ON and OFF, and this causes a reduction in the whole system's efficiency. The proposed boost converter utilizes a soft switching method using an auxiliary circuit with a resonant inductor and capacitor, auxiliary switch, and diodes. Therefore, the proposed soft-switching boost converter reduces switching losses more than the conventional hard-switching converter. The efficiency, which is about 91% in hard switching, increases to about 97% in the proposed soft-switching converter. In this paper, the performance of the proposed soft-switching boost converter is verified through the theoretical analysis, simulation, and experimental results.

I. INTRODUCTION

RECENTLY, switch-mode power supplies have become smaller and lighter due to higher switching frequency. However, higher switching frequency causes lots of periodic losses at turn ON and turn OFF, resulting in increasing losses of the whole system. Therefore, many converters have been presented that use resonance to reduce switching losses. Many researches using resonance have presented a zero-voltage and zero-current switching (ZVZCS) converter that performs zero-voltage switching (ZVS) and zero-current switching (ZCS) simultaneously. However, the auxiliary circuit for resonance

increases the complexity of the circuit, as well as its cost. For some resonant converters with an auxiliary switch, the main switch enables soft switching, while the auxiliary switch performs hard switching. These converters cannot improve the whole system's efficiency owing to the switching losses of the auxiliary switch. A new soft-switching boost converter with an auxiliary switch and resonant circuit is proposed in this paper.

The resonant circuit consists of a resonant inductor, two resonant capacitors, two diodes, and an auxiliary switch. The resonant capacitor is discharged before the main switch is turned ON and the current flows through the body diode. These resonant components make a partial resonant path for the main switch to perform soft switching under the zero-voltage condition using the resonant circuit. Compared with other soft-switching converters, the proposed converter improves the whole system's efficiency by reducing switching losses better than other converters at the same frequency.

In this paper, some simulation results are presented for a 400-W, 200-kHz prototype boost converter using MOSFET. Then, experimental results are presented to verify the steady-state operational principle of the proposed circuit. Additionally, theoretical analyses are presented.

II. LOW-LOSS SOFT-SWITCHING BOOST CONVERTER

A. Configuration of the Proposed Soft-Switching Boost Converter

The proposed converter is shown in Fig. 1. The main switch (S1) and the auxiliary switch (S2) of the proposed circuit enable soft switching through an auxiliary switching block, consisting of an auxiliary switch, two resonant capacitors (Cr and Cr2), a resonant inductor (Lr), and two diodes (D1 and D2).

B. Operational Analysis of the Proposed Converter

The operational principle of the proposed converter can be divided into nine modes. For simple analysis of each mode of the proposed converter, the following assumptions are made. 1) All switching devices and passive elements are ideal. 2) The input voltage (Vin) is constant. 3) The output voltage (Vo) is constant. (Output capacitor Co is large enough.) 4) The recovery time of all diodes is ignored. Fig. 2 shows Equivalent circuit schemes of the operation modes in the proposed converter. And Fig. 3 shows the key waveforms of operation modes.

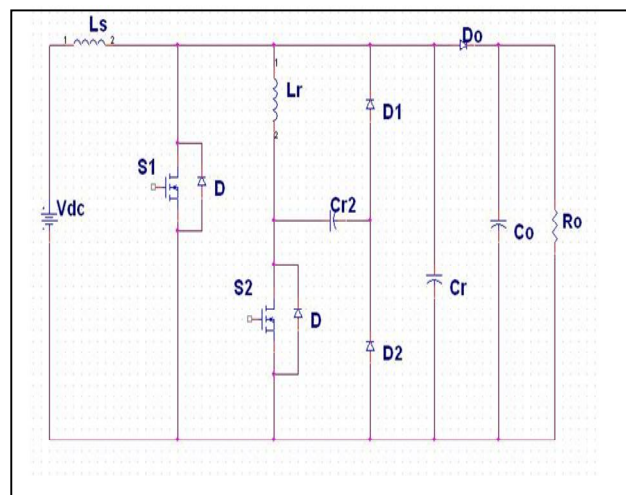

Fig1. Proposed Circuit

III. MODES OF OPERATION

Mode 1 ($t_0 \leq t < t_1$):

All of the switches are turned OFF. The accumulated energy of the main inductor (L) transfers the load through the main diode (Do).

In this mode, the main diode (Do). In this mode, the main inductor voltage and current are represented by (1) and (2), and using these equations, the inductor current can be expressed as (3). During this time, the resonant inductor current is zero, and the resonant capacitor (Cr) has been charged to the output voltage and the resonant,

$$v_L(t) = V_{in} - V_o(t) \dots\dots\dots(1)$$

$$i_{Lr} = \frac{1}{L_m} \int_{t_0}^{t_1} v_{Lr}(t) dt \dots\dots\dots(2)$$

$$i_{Lr} = \frac{V_{in} - V_o}{L_m} [t - t_0] + I(t_0) \dots\dots\dots(3)$$

$$i_{Lr}(t) = 0, \quad V_{Cr}(t) = V_o, \quad V_{Cr2}(t) = V_o \dots\dots\dots(4)$$

Mode 2 ($t_1 \leq t < t_2$):

When the auxiliary switch turns ON, mode 2 begins. After turning ON the auxiliary switch, the resonant inductor current begins to increase linearly from zero. When the resonant inductor current (i_{Lr}) is equal to the main inductor current at t_2 , mode 2 completes and the resonant inductor voltage equals the output voltage. Thus, the resonant inductor current is expressed by (5). The main inductor current decreases and, at the end of this mode, the main inductor current is equal to the minimum, as defined by (6).

$$i_{Lr} = \frac{1}{L_r} \int_{t_1}^{t_2} v_{o}(t) dt$$

$$i_{Lr} = \frac{V_o}{L_r} (t - t_1) \dots\dots\dots(5)$$

$$i_{Lr}(t) = I_{min} \dots\dots\dots(6)$$

Mode 3 ($t_2 \leq t < t_3$):

Immediately after the resonant inductor current and main inductor current have equalized, the main diode is turned OFF. The resonant capacitor Cr and the resonant inductor start their resonance, then the resonant capacitor Cr is discharged through resonant path Cr and Lr . After finishing the resonance, the resonant capacitor voltage is equal to zero. Mode 3 completes at t_3 . At t_2 , the resonant inductor voltage is equal to the output voltage. Thus, the time interval for the two currents to equalize after t_1 is determined

by (7). The resonant inductor current is the sum of the main inductor and resonant current, and is expressed by (8). The resonant capacitor Cr voltage is charged, as expressed by (9). During this mode, the resonant impedance and angular frequency are given by Zr and ω_r

$$t_1 = IL / ((V_o / L_r)) \dots\dots\dots(7)$$

$$i_{Lr}(t) = i_{min}(s) + \frac{V_o(s)\omega_r}{Z_r(S^2 + \omega_r^2)} \dots\dots\dots(8)$$

$$V_{Cr}(t) = V_o \cos(\omega_r(t - t_2)) \dots\dots\dots(9)$$

$$Z_r = \sqrt{\frac{L_r}{C_r}} \dots\dots, \quad \omega_r = \sqrt{\frac{1}{L_r * C_r}} \dots\dots\dots(10)$$

Mode 4 ($t_3 \leq t < t_4$):

As soon as the resonant capacitor (Cr) voltage has reached zero, the body diode of main switch is turned ON naturally. In this case, the main switch voltage is equal to zero and the turn-ON signal is given to the main switch under the zero-voltage condition. In this mode, the main inductor voltage is equal to the input voltage. Thus, the main inductor current is expressed by (11). After the resonance in mode 3, the resonant inductor current is constant. The resonant capacitor (Cr) voltage has been strongly discharged in mode 3. Therefore, the resonant capacitor voltage is zero

$$i_{Lr}(t) = i_{min} + \frac{V_{in}}{L_m} (t - t_3) \dots\dots\dots(11)$$

$$V_{Cr2}(t) = 0 \dots, \quad V_{Cr} = 0 \dots\dots\dots(12)$$

Mode 5 ($t_4 \leq t < t_5$):

In mode 4, the main switch turns ON under the zero-voltage condition. When the auxiliary switch is turned OFF for the same condition, mode 5 begins. In this stage, the resonant inductor and resonant capacitor (Cr2) start the resonance. After the quarter-wave resonance of Lr and Cr2, the current of Lr is zero. Mode 5 is complete and Cr2 has been fully charged by the resonance. In this mode, the resonant inductor current can be expressed as (13). In addition, the resonant impedance and angular frequency are given by Za and ω_a

$$i_{Lr}(t) = i_{Lr}(t_3) \cos(\omega_a(t - t_4)) \dots\dots\dots(13)$$

$$\omega_a = 1 / \sqrt{L_r C_{r2}} \dots\dots, \quad Z_a = \sqrt{\frac{L_r}{C_{r2}}} \dots\dots\dots(14)$$

Mode 6 ($t_5 \leq t < t_6$):

After mode 5 completes, the current flow of the resonant inductor L_r reverses and the next stage starts. In mode 6, a reverse resonance of L and Cr_2 through the main switch and D_2 occurs. When the Cr_2 voltage has reached zero by resonance, the resonance of L_r and Cr_2 is complete and the Cr_2 voltage is zero. During modes 5 and 6, the resonant capacitor voltage is charged and discharged, according to (15). Thus, the resonant capacitor voltage (v_{Cr2}) for each point of time is expressed by (16)

$$V_{Cr2}(t) = Z_a i_{Lr}(t_3) \sin(\omega_a(t-t_4)) \dots\dots\dots(15)$$

$$V_{Cr2}(t_5) = Z_a i_{Lr} \dots\dots V_{Cr2}(t_6) = 0 \dots\dots\dots(16)$$

Mode 7 ($t_6 \leq t < t_7$):

After the Cr_2 voltage has reached zero, the body diode of the auxiliary switch is turned ON. The current flows through the freewheeling path of the body diode—the resonant inductor—the main switch. By the pulsewidth modulation (PWM) algorithm, when the main switch is turned OFF, this mode is complete. In this interval, the magnitude of the resonant inductor current is equal at t_3 . However, the current flow is reversed. In this mode, the main and auxiliary inductor currents are as follows:

$$i_{Lr}(t) = i_{Lr}(t_3) + \frac{V_{in}}{L} (t-t_3) \dots\dots\dots(17)$$

$$i_{Lr}(t) = -i_{Lr}(t_3) \dots\dots\dots(18)$$

Mode 8 ($t_7 \leq t < t_8$):

When the main switch is turned OFF under the zero-voltage condition, mode 8 starts. The sum of the two inductor currents is the charging current of the resonant capacitor Cr in this mode. When the resonant capacitor (Cr) voltage is equal to the output voltage, this mode is completed. Because the two inductor currents charge the resonant capacitor Cr , the resonant inductor current is expressed by (19), and (20) represents the zero-voltage condition

$$i_{Lr}(t) = i_{Lr}(t_7) - \{i_{Lr}(t_7) + i_{Lr}(t_3)\} \cos \omega r t \dots\dots\dots(19)$$

$$Z_r \{i_{Lr}(t_7) + i_{Lr}(t_3)\} > V_o \dots\dots\dots(20)$$

Mode 9 ($t_8 \leq t < t_9$):

At t_8 , the resonant capacitor Cr has been charged and the main diode voltage is zero. Therefore, the main diode turns ON under the zero-voltage condition and the resonant inductor current decreases linearly toward zero. After the current has reached zero, mode 9 completes and the next

switching cycle starts. In this mode, the main inductor current and resonant inductor current are given by the following:

$$i_{Lr}(t) = i_{Lr}(t_7) + \frac{V_o - V_{in}}{L} * t \dots\dots\dots(21)$$

$$i_{Lr}(t) = \frac{V_o}{L_r} * t - i_{Lr}(t_3) \dots\dots\dots(22)$$

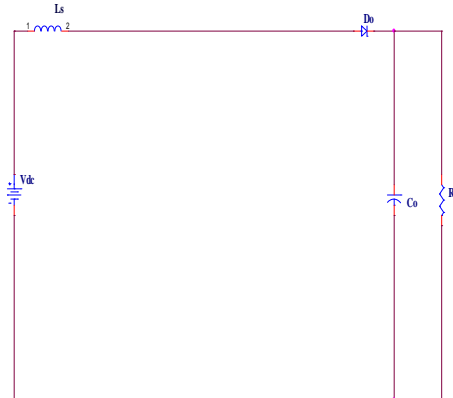

Mode: 1 ($t_0 \leq t < t_1$)

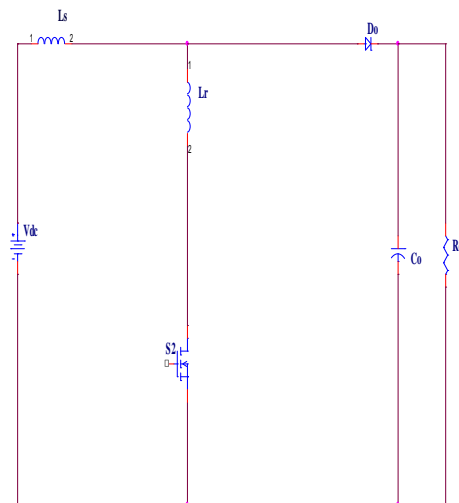

Mode: 2 ($t_1 \leq t < t_2$)

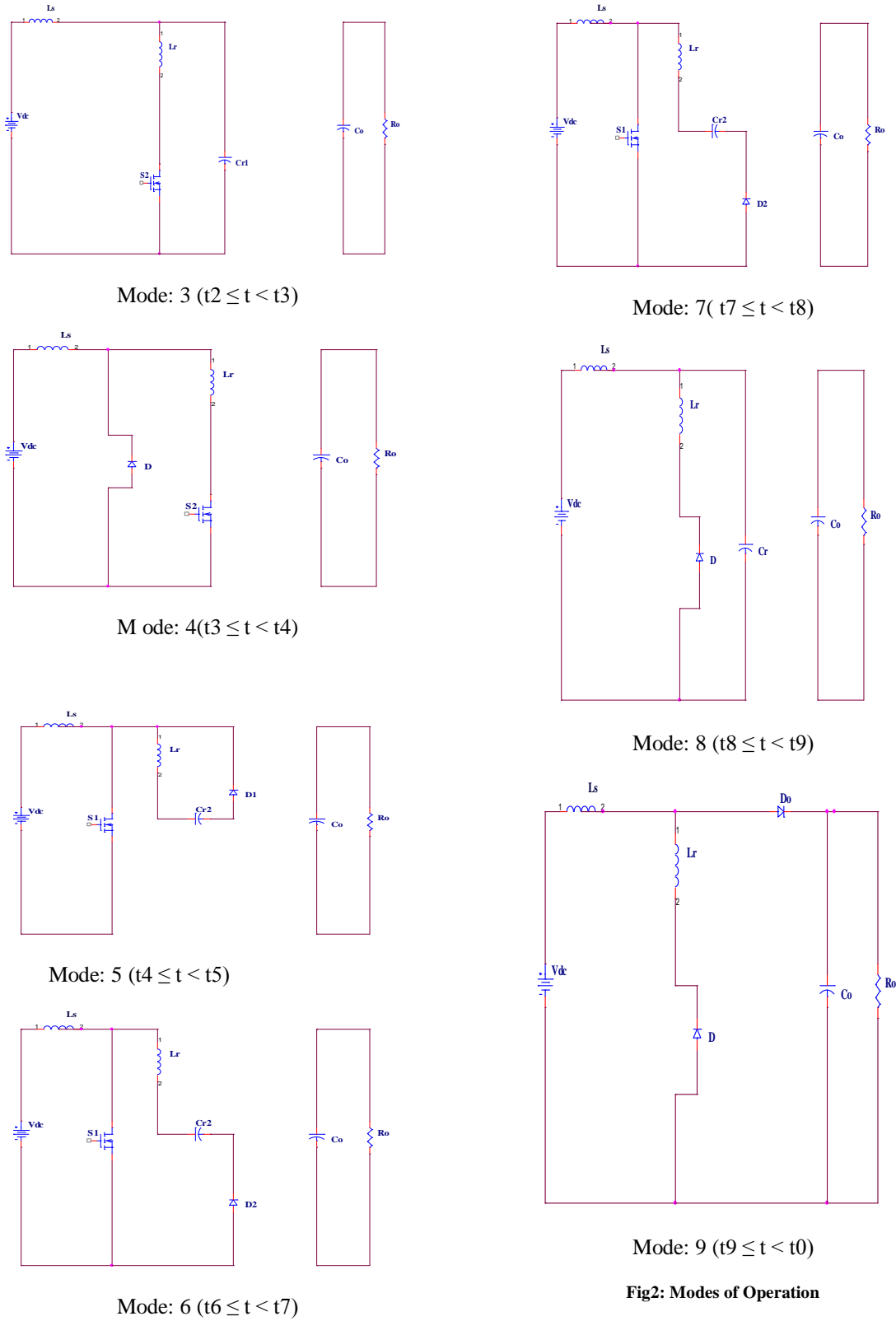

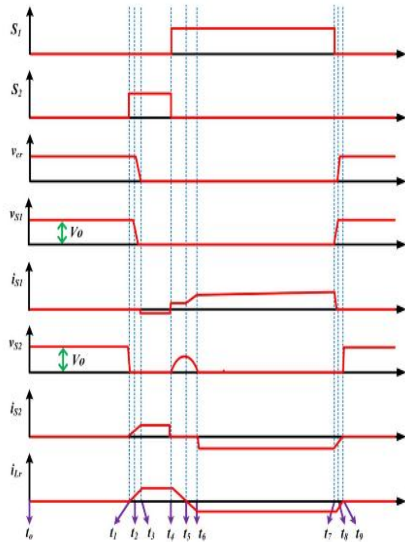

Fig3: Expected Waveforms

TABLE I

PARAMETERS OF THE PROPOSED CIRCUIT

PARAMETER	SYMBOL	VALUE
INPUT VOLTAGE	V_{DC}	50V
OUTPUT VOLTAGE	V_O	200V
SWITCHING FREQUENCY	F_r	200KHz
RESONANT INDUCTOR	L_r	16.5 μ H
RESONANT CAPACITOR	C_r	1nF
RESONANT CAPACITOR2	C_{r2}	16.5nF

IV. SIMULATION RESULTS

In this paper the proposed converter is simulated by ORCAD 16.5 software. The simulation was performed under a 200-kHz switching frequency and a 50-V input voltage. Figs. 4 and 5 show the simulation waveforms of the main gate voltage and voltage across switch S1 and current, flowing through it respectively. Before the main switch is turned ON, the body diode is turned ON. As a result, the main switch enables zero-voltage switching and the auxiliary switch performs soft switching. Fig 6 shows that output voltage V_o and output current I_o .

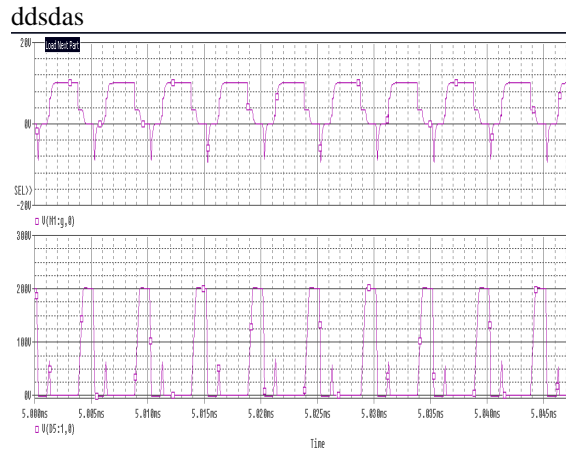

Fig4: Vgs1 and Vs1

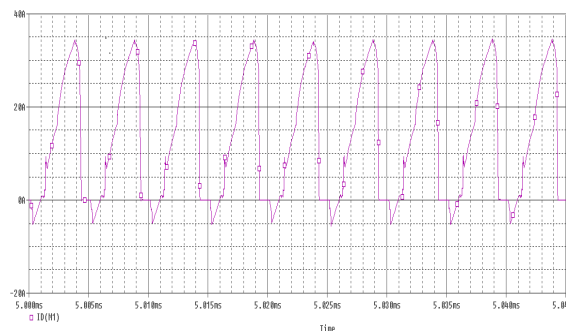

Fig5:Current across switch S1, Is1

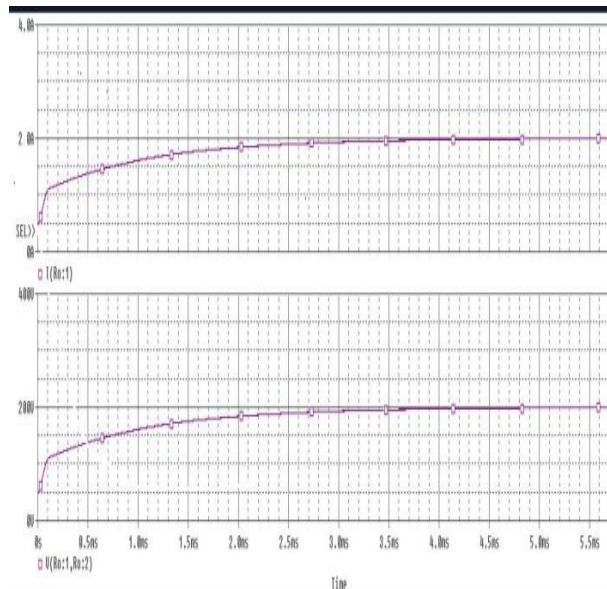

Fig6: Output current I_o and Output Voltage V_o

REFERENCES

- [1] G. Hua, C.-S. Leu, Y. Jiang, and F. C. Y. Lee, "Novel zero-voltage transition PWM converters," *IEEE Trans. Power Electron.*, vol. 9, no. 2, pp. 213–219, Mar. 1994.
- [2] G. Hua, E. X. Yang, Y. Jiang, and F. C. Y. Lee, "Novel zero-current transition PWM converters," *IEEE Trans. Power Electron.*, vol. 9, no. 6, pp. 601–606, Nov. 1994.
- [3] H. Bodur and A. F. Bakan, "A new ZVT-ZCT-PWM DC-DC converter," *IEEE Trans. Power Electron.*, vol. 19, no. 3, pp. 676–684, May 2004.
- [4] H. Bodur and A. F. Bakan, "A new ZVT-PWM DC-DC converter," *IEEE Trans. Power Electron.*, vol. 17, no. 1, pp. 40–47, Jan. 2002.
- [5] S. S. Saha, B. Majumdar, T. Halder, and S. K. Biswas, "New fully softswitched boost-converter with reduced conduction losses," in *Proc. Power Electron. Drive Syst. 2005 Int. Conf.*, Jan., 2006, vol. 1, pp. 107–112.
- [6] N. Jain, P. K. Jain, and G. Joos, "A zero voltage transition boost converter employing a soft switching auxiliary circuit with reduced conduction losses," *IEEE Trans. Power Electron.*, vol. 19, no. 1, pp. 130–139, Jan. 2004.
- [7] B. R. Lin and J. J. Chen, "Analysis and implementation of a soft switching converter with high-voltage conversion ratio," *IET Power Electron.* vol. 1, no. 3, pp. 386–394, Sep. 2008.
- [8] L. Jong-Jae, K. Jung-Min, K. Eung-Ho, and K. Bong-Hwan, "Dual series resonant active clamp converter," *IEEE Trans. Ind. Electron.*, vol. 55, no. 2, pp. 699–710, Feb. 2008.
- [9] X. Wu, J. Zhang, X. Ye, and Z. Qian, "Analysis and derivations for a family ZVS converter based on a new active clamp ZVS cell," *IEEE Trans. Ind. Electron.*, vol. 55, no. 2, pp. 773–781, Feb. 2008.
- [10] D. W. Erning and A. R. Hefner, Jr., "IGBT model validation for softswitching applications," *IEEE Trans. Ind. Appl.*, vol. 37, no. 2, pp. 650–660, Mar./Apr. 2001.
- [11] S.-R. Park, S.-H. Park, C.-Y. Won, and Y.-C. Jung, "Lowloss soft switching boost converter," in *Proc. 13th Power Electron. Motion Control Conf 2008*, Sep. 2008, pp. 181–186.

