



**Gerrit du Plessis**  
Senior Engineer: TNPA  
Port of Ngqura  
gerrit.duplessis2@transnet.net

## OTHER PROJECTS

# Construction of the Port of Ngqura

## Phase 2: Maritime and Civil Works, November 2006 to May 2011

This article follows on the overview article published in the May 2010 edition of *Civil Engineering* (pp 20 – 26) and covers a portion of the work done after completion of the Phase 1 Main Maritime Contract

### BACKGROUND, AIMS AND OBJECTIVES

The main objective of Phase 2 was to complete the remainder of the infrastructure (see Figure 1), following the completion of the Phase 1 main maritime infrastructure during February 2006, and to operationalise the Port of Ngqura (PoN) for handling of containers, as well as other bulk and breakbulk cargoes.

The Phase 2 Project involved the following:

- Maritime works
  - Extension of the 780 m container quay by 520 m.
  - Removal of a shipwreck from turning circle.
  - Dredging of a berm wall at the container quay wall extension (project has been deferred).
- Civil works
  - Provision of concrete paving, roads, a road bridge and services.
- Electrical reticulation
  - Provision of complete electrical reticulation with back-up generators.
- Buildings
  - Construction of operational buildings and sub-stations.
- Security and operational systems



- Provision of fencing and access control.
- Provision of latest technology operational systems for container handling, as well as SCADA, navigational aids and vessel tracking.
- Rail works
  - Construction of a marshalling yard and rail link to the Ngqura Container Terminal (NCT), including a rail bridge over the Coega River.
- Equipment for vessel handling and container operations
  - Provision of equipment for 720 m long container berths, such as ship to shore gantry cranes and rail-mounted gantry cranes. Provision of three tugs and a pilot boat.

This article covers only the first two items listed above, namely the maritime and civil works. Please note that not all



Phase 2 contracts / contractors could be listed in this article since a total number of 123 contracts were awarded.

### **MARITIME WORKS: CONTAINER QUAY WALL EXTENSION**

The contract for the extension of the container quay wall and associated paving, with services, was awarded to Hochtief Concor Joint Venture (HCJV) on 19 October 2007 for completion by 17 May 2011. The works included the extension of the existing 780 m container quay wall by 520 m, constructed in a dewatered excavation, to provide a total berth length of 1 300 m with a depth of -16 m CD.

The quay wall design that was finally adopted for both Phase 1 and 2 construction was a mass concrete gravity voided

quay wall comprising 20 m long sections made up of 6 x voided blocks, each 3 m high, including heavily reinforced concrete foundation and mass capping with heights of 3 m and 3,4 m respectively. Figures 2 to 6 show a typical section through the quay wall, as well as construction details.

The mass capping of the container quays comprises two service tunnels sealed with UPVC water stops between blocks with drainage, whereas the bulk berths have only one service tunnel. The dewatered quay wall construction method proved to be the most cost effective and controllable, ensuring a sound and durable structure that is properly founded and has no risk of backfill materials leaking through the joints, since all joints between blocks were sealed off by

① Phase 2 progress, May 2010

means of geofabric. The latter is critical to achieve and is much more difficult to control when constructed in the wet. The area where the 520 m quay wall extension would be constructed was reclaimed during Phase 1.

The quay wall is stepped back at the rear by means of precast elements and constructed in 3 m high lifts (see Figure 2). The total volume of concrete per 20 m block of quay wall is 2 610,3 m<sup>3</sup> or 130,5 m<sup>3</sup> per running metre. Average production rates of 600 m<sup>3</sup> per day, but up to 800 m<sup>3</sup> per day, were achieved during concrete pouring. The design also incorporated a sub-surface type drainage arrangement with 200 mm diameter UPVC pipes with stone wrapped in



- 2 Section through container quay wall
- 3 Quay wall construction in excavation pit
- 4 Quay wall foundation and scour slab construction in excavation pit

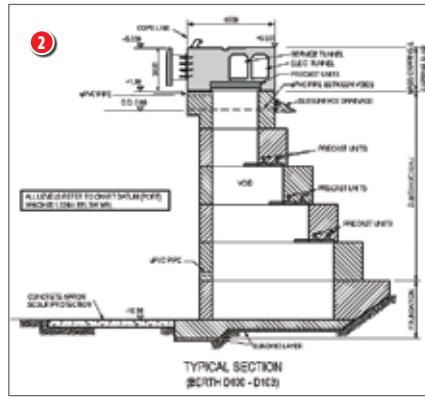

geofabric and provided at a level of 0,0 m CD to equalise the water pressures on both sides of the quay wall. The basin side of the quay wall also has 200 mm diameter openings to allow the voids in the quay wall substructure to be filled with water to increase the stability.

The cope level of the quay wall is at +5,0 m CD and the structure is founded at a level of -18 m CD in cretaceous bedrock in the form of mudstone. Due to rapid weathering of the cretaceous bedrock on exposure, concrete had to be placed as soon as possible, but not later than eight days after exposing the founding material.

The front of the quay wall foundation is protected with a 10 m wide by 0,6 m thick unreinforced concrete scour slab to prevent undermining of the quay wall foundation due to vessel/tug propeller or side-thruster action. The non-protection of quay walls against scouring action in other ports has resulted in difficult and costly repairs to rectify undermining. Undermining of quay walls reduces the Factor of Safety against overturning significantly and could result in failure of the quay wall.

Durability of the concrete in a marine environment is of critical importance. All mass and reinforced concrete therefore contained 25 to 30% fly ash to enhance the durability and workability of the concrete. Concrete with a design strength of 40 Mpa was specified for reinforced concrete and 25 Mpa for unreinforced mass concrete. A concrete cover to steel reinforcement of 100 mm was also specified on the front face of the quay wall, with a minimum of 60 mm in other areas. A maximum water / cement ratio of 0,4 was specified.

Supply and installation of the following fittings to the quay wall were also included in the scope:

- Ship to shore crane storm pin anchors
- Ship to shore crane tie-down anchors with a capacity exceeding 140 t
- Bollards spaced at 20 m with a design capacity of 150 t
- Maritime international type frictionless fenders, or similar, with polyethylene front sheeting spaced at 20 m with an energy absorption exceeding 1 100 Knm and a resultant hull pressure of less than 250 Kpa

The PoN quay walls are the strongest of all quay walls in the TNPA (Transnet National Ports Authority) port system. The bulk berths were designed for

85 000 deadweight tons (DWT) vessels and the container berths for a 6 600 TEU (Twenty Foot Equivalent Unit) vessel. Further investigations have indicated that the bulk berths could accommodate 100 000 DWT (120 000 t displacement) vessels, while the the container berths could handle super-post panamax vessels of 12 500 TEUs with a draught of 14,5 m. Any deviation from the design vessel will result in a reduced Factor of Safety and will need to be considered carefully when allowing such vessels into the port. The final decision on the maximum size vessel that can be allowed into the port would ultimately be taken by the Harbour Master, who would take into account the design capacity of the entire port infrastructure (e.g. channel, basin, berth), weather and tidal conditions, and berthing operations.

The upper 3,4 m thick section of the quay wall is capable of withstanding crane outrigger loads of 600 Kpa. The surface behind the quay wall was designed for a UDL of 80 Kpa. The quay wall has been designed for a crane wheel loading of

two bogeys each (of eight wheels) with a maximum load of 913 kN per wheel, where wheel and bogey centres are 1,2 m and 12,2 m respectively.

The quay wall excavation profile was triangular-shaped, excavated from an elevation of +4 m CD (total width of 135 m at this level) to a depth of -18 m CD (total width of 23 m at this level) with 1:2 side slopes and benches of 4 m wide (see Figure 5).

The 1,2 million m<sup>3</sup> of earthworks involved the selection of 462 000 m<sup>3</sup> of medium and coarse sand or gravel, as identified in the Unified Soil Classification system, for backfilling behind the quay walls, and the remainder was spoiled inside the port area. All sand and gravel fill was compacted to 98% and 95% MOD AASHTO respectively.

An 1 800 m long cement/bentonite slurry cut-off wall was constructed in two cells around the quay wall excavation by means of a hydrofraise cutter since many areas did not allow the use of a normal mechanical or hydraulic grab, due to very hard layers of cemented calcarenite. The

slurry cut-off wall was sealed off into the cretaceous bedrock at various levels, but generally between -18 m and -22 m CD.

Continuous dewatering of the quay wall construction pit was carried out to keep the water table below -18 m CD by a combination of deep well dewatering, well pointing and pumping from an open surface channel system behind the slurry wall. The wells were equipped with submersible pumps. The average volume of water pumped from the pit was 288 m<sup>3</sup> per day and was extremely low due to a very effective key achieved in the cretaceous mudstone material.

Upon completion of the quay wall construction to above high-water level, including backfilling, the construction pit was flooded in a controlled manner during May 2010. Figure 7 shows the schematic flooding arrangement. The methodology for the flooding of the quay excavation pit was as follows:

- The excavation pit was maintained in a dry condition after completion of the excavations to allow for the dry construction of the final works. The surface





pumps continued pumping for as long as it was required to manage the inflow from the sides of the basin, and the deep wells were kept running during a part of the flooding process in order to ensure slope stability.

- Flooding was by means of controlled gravitational flow through 3 x 450 mm diameter pipes that were fitted with valves. The pipes were connected to a water intake structure located at a level of  $-0,5$  m CD. Flooding of the pit was planned to take place over a period of 14 days.
- In order to avoid the inflow of water at the moment of the installation of the pipes, which would pass through the slurry wall, a clay core was installed at both sides of the slurry wall in the area where the pipes would be located. The clay core reached to  $-1,5$  m CD and surrounded the full area of the intake structure in order to ensure water tightness during the installation process.
- Once the water intake structure had been installed and the pipe system connected, the water channel towards the intake structure was excavated. The water intake channel was protected with rip-rap material in order to avoid scouring effect and transport of sand into the excavated basin.
- The water intake pipe was fixed on the present slope close to the existing quay wall and the water outlet located and fixed on the scour slab in such a way that no erosion would occur during the flooding process.
- Once the basin had been flooded, and after removal of the piping system for the flooding, the removal of the revetment and bund started.



Dredging of the full 700 m seaside berm will be carried out under a different contract in future when required, except for a 100 m section that forms part of the current project and will be done under a different contract for which tenders were recently advertised.



- ⑤ Quay wall foundation and scour slab construction in excavation pit with container quay walls constructed under Phase 1 in the background
- ⑥ Construction of voided quay wall substructure with 10 m wide scour slabs
- ⑦ Elevation of end of the container quay wall constructed under Phase 1, with schematic arrangement for flooding of the excavation, scheduled for May 2010



## CIVIL WORKS: CONTAINER TERMINAL

The main contract for the first part of the Phase 2 container terminal works was awarded to Grinaker-LTA on 6 December 2006 for completion by 24 June 2009. Numerous other contractors were also involved in other parts of the construction.

The works primarily involved the provision of all infrastructure for the container terminal behind the 780 m long container quay wall (constructed during Phase 1), as well as in other areas in the port. It comprised bulk earthworks, heavy-duty concrete paving behind the quay, construction of crane beams for ship to shore (STS) gantry cranes together with the construction of a rail transfer area, roads and services (e.g. storm water drainage, water supplies, sewerage, services tunnels and pipe-and-chamber systems for electrical and communication reticulation, as well as the installation of crane rails, bollards and storm bollards). Figures 9 and 10 show details of the concrete paving and other works at the container terminal.

The container terminal has been designed for the operation of heavy container handling equipment, such as rubber tyre gantries (RTG) and reach stackers. The concrete paving slopes 1:100 towards the quay wall over a distance of 400 m.

The bulk of the 35 Mpa concrete paving comprises a 450 mm thick unreinforced concrete slab that incorporates various slab jointing requirements on a 150 mm G3 layer compacted to 95% MOD AASHTO on the in situ material. The only areas where the paving slab was reinforced were at the rigid supports, e.g. the recessed roof of the service tunnel, and the slot drains. Concrete paving was constructed at an average rate of 800 m<sup>3</sup> per day and peaked at 1 300 m<sup>3</sup> per day. Very few uncontrolled cracking occurred and in most cases these cracks were reamed and sealed with a polyurethane sealant. Since reinforcing was provided in a few areas only, there was no risk of corrosion, and the aggregate interlock was sufficient for load transfer. The specification for the joint between slabs was a rectangular 8 mm wide saw cut joint. Due to undesirable edge breaking of the concrete in a number of areas after sealing with a polyurethane joint sealant, the joint design was amended to

incorporate a 3-5 mm chamfer, with the sealant slightly recessed below the surface. This amendment has shown very promising results.

In an attempt to ensure minimum settlement of the paving after construction, the in situ material which had been back-filled behind the quay wall excavation as part of the Phase 1 reclamation, was compacted by means of 45 passes or 90 runs of an impact roller delivering an energy of 25 KJ. Continuous monitoring of the compaction efficiency was done using the Continuous Impact Response method.

- 8 Container quay wall excavation pit flooded and removal of bund wall in preparation for dredging
- 9 Concrete surfacing, 40 m high-mast lights, STS cranes and RTGs



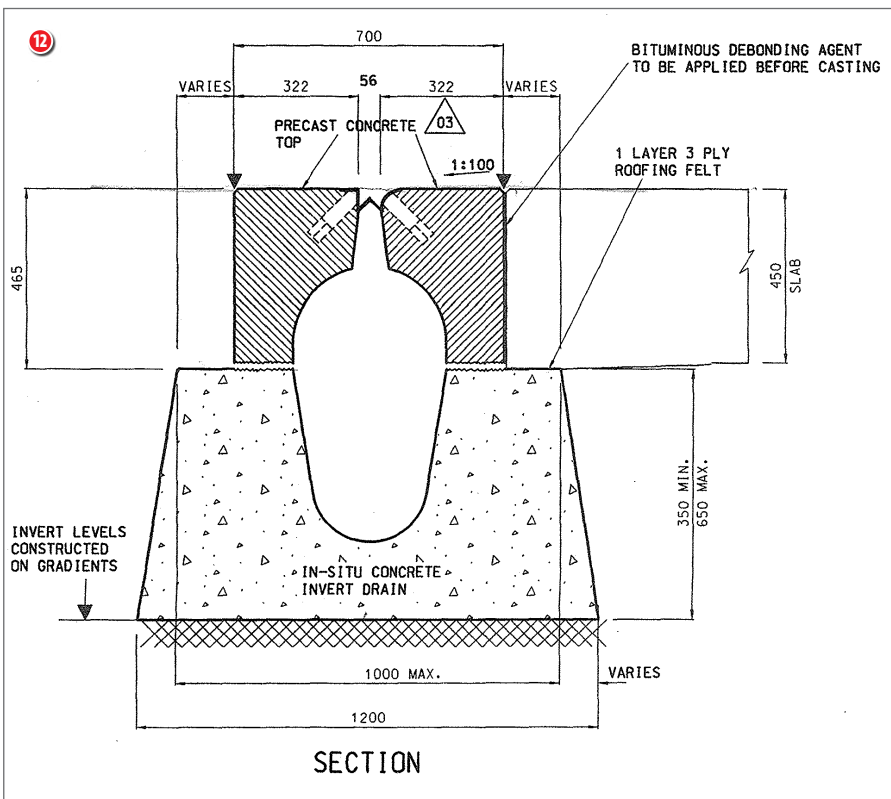

Optimum impact rolling very close to the specified 45 passes was achieved, with an average settlement of 70 mm and a maximum of 120 mm. The areas of settlement were filled in with additional G3 material before casting of concrete.

Storm bollards with a 300 t capacity were also provided at an average spacing of 70 m. The storm bollards are positioned at a distance of 77 m from the cope line and recessed into the concrete slab, so as not to hinder any operations.

The STS crane beams comprised 30 m long reinforced beams, 3,0 m wide x 1,2 m high, with crane anchor pins and earth rods. Type A120 continuously thermit welded crane rails with a yield stress of 690 Mpa were provided on a 7 mm thick Gantrex rubber pad and secured to a 20 mm thick sole plate by means of a Gantrex boltable clip assembly with a self-locking cam.

Construction tolerances of the 30,48 m gauge crane rails were extremely strict and commissioning of the STS cranes was subject to approval of the crane rail installation by the crane manufacturer.

A 10 m wide asphalt road consisting of 2 x 50 mm asphalt layers on 3 x 150 mm G3 layers, stretching between the back of the concrete mass capping and the 450 mm thick paving, extends along the length of the quay wall. The purpose of the 10 m wide asphalt road in lieu of concrete paving is to enable the easy correction of any unavoidable settlement immediately behind the quay wall.

The storm water paving, sloping in one direction towards the quay wall, comprises slot drains that run parallel to the quay wall at a spacing of 65,5 m and ties into storm water pipes that are orientated perpendicularly to the quay, spaced at 140 m centres, and discharging through the quay wall. All 1 500 mm diameter storm water pipe outlets, immediately behind the back of the quay wall, were provided with reinforced concrete collars that are capable of moving vertically where the pipes butt up against the recessed storm water outlet of the rigid

10 Concrete surfacing, rail transfer area and refrigerated container structures near rail transfer area

11 Slot drain and concrete paving with erection of STS cranes under way in the background

12 Section through storm water slot drain in container paving



quay wall to prevent shearing of the pipes. The slot drains consist of two sections. The excavation for the slot drain base was done to the required slope, whereafter an adjustable purpose-made shutter was placed on a blinding layer to form the drainage channel of the slot drain, while the outer horizontal sides of the shutter were lifted to the required level, allowing for a precast concrete top section to be grouted afterwards. Hot-dipped galvanised steel corner sections were provided to protect the corners of the slot drains against damage. Figures 11 and 12 show details of the slot drains.

The service tunnels within the terminal paving encompass 20 m long cast in situ reinforced concrete structures, that form a 1,1 m wide by 1,8 m high chamber, all sealed with UPVC water stops at the joints. These service tunnels are used for running the electrical reticulation to supply the STS cranes, refrigerated containers and other equipment.

High-mast light foundations for 40 m high-mast lights, measuring 4,5 m in diameter, were also constructed.

Durability of the concrete in a marine environment is of critical importance. All mass and reinforced concrete contained 25 – 30% fly ash by mass to assist with the workability and durability of the concrete. In the design of the works, special cognisance was taken of the aggressive marine environment. Most materials were therefore specified as Grade 316 stainless steel, 3CR12 or heavy duty hot-dipped galvanised.

## CONCLUSION

The Port of Ngqura is a new deepwater port located on South Africa's east coast. The port started operations on 4 October 2009 and consists of two container berths, with a further two due for completion in May 2011 (excluding dredging), two bulk / breakbulk berths and a liquid bulk berth. The port is ideally positioned to deal with container import and export from across the globe, as well as transshipment cargoes serving east and west coast traffic and also inter-line traffic from South America to Asia.

The container berths can handle some of the largest container vessels around the globe (12 500 TEUs with 14,5 m draught) and the bulk/breakbulk/liquid berths can handle vessels of up to 100 000 deadweight t (120 000 t displacement).

The PoN is a deepwater port and the medium to long-term expectations are:

- That the port would attract new transshipment volumes under the container hub principle, as well as handle an increasing number of Gauteng containers.
  - That the port would also serve as a bulk port to handle commodities such as manganese, chemicals, oil and refined petroleum products.
  - That the port would handle cargoes generated by the Coega industrial Development Zone (CIDZ). None of these potential cargoes have been finalised yet, but collectively indicate that the port could play a significant role as a bulk port serving the CIDZ. These projects include a possible PetroSA refinery and a range of smaller, but significant freight-generating operations.
- The Ngqura Container Terminal has a current capacity of 800 000 TEUs per annum and, once completed, the port will be one of the largest of its kind in South Africa, servicing almost 2 million TEUs per annum.

The PoN covers a total land area of 1 254 ha and is ideally situated, with a huge industrial development zone immediately adjacent to the port. The port has enormous potential for future development, with the possibility of expanding up the Coega River for bulk/breakbulk/liquid terminals, and along the coast for container terminals.

## ACKNOWLEDGEMENTS

### Phase 1 Project

#### ■ Main consultants

Prestedge, Retief, Dresner and Wijnberg (Lead consultant)  
Entech  
Protekon Design Office (a Transnet division)

#### ■ Project Management

TNPA staff

### Phase 2 Project

#### ■ Main consultants

HMG-JV (joint venture between Hatch, Mott MacDonald & Goba)  
WSP  
Prestedge, Retief, Dresner and Wijnberg  
Transnet Design Services

#### ■ Project Management

HMG-JV  
Transnet Capital Projects

The author would like to acknowledge all the above-mentioned, as well as contractors referred to in this article, for their assistance in compiling this report and releasing information. □

*The Port of Ngqura is a new deepwater port located on South Africa's east coast. The port started operations on 4 October 2009 and consists of two container berths, with a further two due for completion in May 2011 (excluding dredging), two bulk / breakbulk berths and a liquid bulk berth. The port is ideally positioned to deal with container import and export from across the globe, as well as transshipment cargoes serving east and west coast traffic and also inter-line traffic from South America to Asia*



Source:

[http://www.saice.org.za/downloads/monthly\\_publications/2010/2010-Civil-Engineering-aug/#/0](http://www.saice.org.za/downloads/monthly_publications/2010/2010-Civil-Engineering-aug/#/0)