

CONTROL VALVE SIZING, SELECTION AND MAINTENANCE

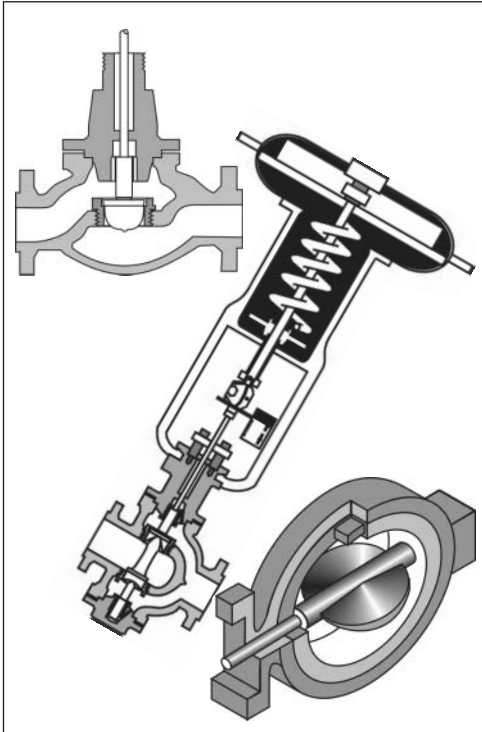

WHO SHOULD ATTEND:

- Control Valve Specialists
- Plant Safety Specialists
- Instrumentation and Control Engineers and Technicians
- Electrical Engineers
- Project Engineers
- Process Control Engineers
- Consulting Engineers
- Maintenance Engineers and Technicians
- Maintenance Planners
- Systems Engineers



THE WORKSHOP

It is claimed that the majority of control valves throughout the world have not been correctly sized and that large numbers operate on manual mode. Whether this is true or not is difficult to establish but we do know that the method of sizing and selecting a control valve for a specific application is generally not well understood. Although there are many factors that need to be taken into account the subject is not difficult to understand if dealt with in a logical manner.

We also find that many maintenance problems result from people treating the symptoms of a problem rather than tackling the true cause - a basic understanding of the principles is all that is usually needed to solve the problem for good.

TRAINING METHODOLOGY

The latest educational methods and strategies will be employed. The course is designed to maximise delegate benefit from the outset. Questions are encouraged throughout. This provides opportunities for participants to discuss with the presenter and others, specific problems and appropriate solutions. All delegates take away a detailed and comprehensive copy of the material presented, therefore minimal note taking is encouraged to ensure maximum delegate participation and attention. Practical hands-on training ensures knowledge retention

PRE-REQUISITES

No specialist knowledge or skills are required - only a technical background so that there is an understanding for such factors as the difference between pressure and force.

This course is a good introduction to someone who has had no dealings with control valves in the past as well as an important refresher course for control valve specialists who benefit from the back-to-basics approach.

WORKSHOP OBJECTIVES

At the end of this workshop participants will be able to:

- Understand what happens inside a control valve from basic fluid mechanics point of view
- Appreciate the difference between cavitation and flashing, and know what choked flow is
- Do simple calculations to determine CV values
- Recognise severe service applications and have an appreciation for the methods of tackling the problems associated with such applications
- Know about all the different types of control valves commonly in use and understand the relative advantages of each
- Choose between different characteristics on offer and specify seat leakage rates
- Size actuators for linear and rotary applications and know the relative advantages of pneumatic, hydraulic and electric types
- Have a basic understanding on how to select materials for bodies, trims, packing boxes, and gaskets
- Make use of a computer sizing program to assist with the selection of control valves
- Understand the failure modes for control valves and demonstrate new approaches to troubleshooting

THE PROGRAM

DAY ONE

INTRODUCTION TO CONTROL VALVE THEORY

- Introduction
- Definition of a control valve
- Energy types
- What is happening inside a control valve
- Cavitation
- Flashing
- Choked Flow
- Valve Coefficient Cv

DIFFERENT TYPES OF CONTROL VALVES

- Globe Valves
- Butterfly
- Eccentric disk
- Ball
- Rotary Plug
- Diaphragm and Pinch

CHARACTERISTICS

- Equal percent
- Linear
- Quick opening
- Selection method

HIGH PRESSURE DROP APPLICATIONS

- Cavitation Control
- Cavitation Elimination
- Low Noise
- Diffuser Plates
- Chokes
- Disk Stack Technology
- Pressure Balanced Trim

USE OF COMPUTER PROGRAM FOR VALVE SIZING

EXAMPLES OF HIGH PRESSURE DROP APPLICATIONS

- Water - pump bypass
- Steam - turbine bypass
- Gas - pressure reducing
- Oil - choke valve

DAY TWO

ACTUATORS

- Pneumatic
- Hydraulic
- Electric
- Sizing on rotary valves
- Sizing on linear valves
- Mounting considerations
- Manual overrides
- Accessories

POSITIONERS

- Basic principles
- Conventional pneumatic
- Conventional electro-pneumatic
- Smart Positioners
- Feedback options

PNEUMATIC CIRCUITS

- Volume tank fail system
- Fail fix
- Volume boosters

MATERIALS

- Body materials and pressure ratings
- Trim
- Packing
- Guides and gaskets

QUALITY STANDARDS

- ASME
- NACE
- ISO 9000/2000
- PED
- NAMUR

INSTALLATION / MAINTENANCE

- Installation
- Commissioning
- Routine Maintenance
- Fault finding
- Modes of failure

SUMMARY, OPEN FORUM & CLOSING

ON-SITE TRAINING

— contact us for a proposal today

IDC Technologies unique on-site training delivery service can save your company up to 50%, or more, off the total per-head costs associated with delegates attending a public workshop. One of our qualified and experienced Instructors can discuss the content with you, then come to your venue and present a workshop designed to your own specifications!

Why not call or e-mail and ask about having components from a number of courses combined together? It's affordable, effective, convenient and much easier than you may have thought.

"Technology Training that Works" we mean it! Try us soon and see the difference. For more information, or a customized proposal to run any of our practical workshops at your own venue, contact your nearest business development manager for manager (see page 32).