

Practical Pumps: Design, Operation and Maintenance for  
Centrifugal and Positive Displacement Pumps

## **THIS BOOK WAS DEVELOPED BY IDC TECHNOLOGIES**

### **WHO ARE WE?**

IDC Technologies is internationally acknowledged as the premier provider of practical, technical training for engineers and technicians.

We specialize in the fields of electrical systems, industrial data communications, telecommunications, automation and control, mechanical engineering, chemical and civil engineering, and are continually adding to our portfolio of over 60 different workshops. Our instructors are highly respected in their fields of expertise and in the last ten years have trained over 200,000 engineers, scientists and technicians.

With offices conveniently located worldwide, IDC Technologies has an enthusiastic team of professional engineers, technicians and support staff who are committed to providing the highest level of training and consultancy.

### **TECHNICAL WORKSHOPS TRAINING THAT WORKS**

We deliver engineering and technology training that will maximize your business goals. In today's competitive environment, you require training that will help you and your organization to achieve its goals and produce a large return on investment. With our 'training that works' objective you and your organization will:

- Get job-related skills that you need to achieve your business goals
- Improve the operation and design of your equipment and plant
- Improve your troubleshooting abilities
- Sharpen your competitive edge
- Boost morale and retain valuable staff
- Save time and money

### **EXPERT INSTRUCTORS**

We search the world for good quality instructors who have three outstanding attributes:

1. Expert knowledge and experience – of the course topic
2. Superb training abilities – to ensure the know-how is transferred effectively and quickly to you in a practical, hands-on way
3. Listening skills – they listen carefully to the needs of the participants and want to ensure that you benefit from the experience.

Each and every instructor is evaluated by the delegates and we assess the presentation after every class to ensure that the instructor stays on track in presenting outstanding courses.

### **HANDS-ON APPROACH TO TRAINING**

All IDC Technologies workshops include practical, hands-on sessions where the delegates are given the opportunity to apply in practice the theory they have learnt.

### **REFERENCE MATERIALS**

A fully illustrated workshop book with hundreds of pages of tables, charts, figures and handy hints, plus considerable reference material is provided FREE of charge to each delegate.

### **ACCREDITATION AND CONTINUING EDUCATION**

Satisfactory completion of all IDC workshops satisfies the requirements of the International Association for Continuing Education and Training for the award of 1.4 Continuing Education Units.

IDC workshops also satisfy criteria for Continuing Professional Development according to the requirements of the Institution of Electrical Engineers and Institution of Measurement and Control in the UK, Institution of Engineers in Australia, Institution of Engineers New Zealand, and others.

## **CERTIFICATE OF ATTENDANCE**

Each delegate receives a Certificate of Attendance documenting their experience.

## **100% MONEY BACK GUARANTEE**

IDC Technologies' engineers have put considerable time and experience into ensuring that you gain maximum value from each workshop. If by lunchtime on the first day you decide that the workshop is not appropriate for your requirements, please let us know so that we can arrange a 100% refund of your fee.

## **ONSITE WORKSHOPS**

All IDC Technologies Training Workshops are available on an on-site basis, presented at the venue of your choice, saving delegates travel time and expenses, thus providing your company with even greater savings.

## **OFFICE LOCATIONS**

AUSTRALIA • CANADA • INDIA • IRELAND • MALAYSIA • NEW ZEALAND • POLAND •  
SINGAPORE • SOUTH AFRICA • UNITED KINGDOM • UNITED STATES

**idc@idc-online.com**

**www.idc-online.com**

Visit our website for **FREE** Pocket Guides

**IDC Technologies produce a set of 6 Pocket Guides used by thousands of engineers and technicians worldwide.**

Vol. 1 – **ELECTRONICS**

Vol. 4 – **INSTRUMENTATION**

Vol. 2 – **ELECTRICAL**

Vol. 5 – **FORMULAE & CONVERSIONS**

Vol. 3 – **COMMUNICATIONS**

Vol. 6 – **INDUSTRIAL AUTOMATION**

To download a **FREE** copy of these internationally best selling pocket guides go to:

**[www.idc-online.com/downloads/](http://www.idc-online.com/downloads/)**





*Technology Training that Works*

**Presents**

**Practical Pumps**  
***Design, Operation and Maintenance for Centrifugal  
and Positive Displacement Pumps***

*Website: [www.idc-online.com](http://www.idc-online.com)*

*E-mail: [idc@idc-online.com](mailto:idc@idc-online.com)*

IDC Technologies Pty Ltd  
PO Box 1093, West Perth, Western Australia 6872  
Offices in Australia, New Zealand, Singapore, United Kingdom, Ireland, Malaysia, Poland, United States of America, Canada, South Africa and India

Copyright © IDC Technologies 2011. All rights reserved.

First published 2009

All rights to this publication, associated software and workshop are reserved. No part of this publication may be reproduced, stored in a retrieval system or transmitted in any form or by any means electronic, mechanical, photocopying, recording or otherwise without the prior written permission of the publisher. All enquiries should be made to the publisher at the address above.

### **Disclaimer**

Whilst all reasonable care has been taken to ensure that the descriptions, opinions, programs, listings, software and diagrams are accurate and workable, IDC Technologies do not accept any legal responsibility or liability to any person, organization or other entity for any direct loss, consequential loss or damage, however caused, that may be suffered as a result of the use of this publication or the associated workshop and software.

In case of any uncertainty, we recommend that you contact IDC Technologies for clarification or assistance.

### **Trademarks**

All logos and trademarks belong to, and are copyrighted to, their companies respectively.

### **Acknowledgements**

IDC Technologies expresses its sincere thanks to all those engineers and technicians on our training workshops who freely made available their expertise in preparing this manual.

# Contents

<b>1</b>	<b>Introduction</b>	<b>1</b>
1.1	Introduction	1
1.2	Applications	3
1.3	Types of pumps	3
1.4	Reciprocating pumps	4
1.5	Other types of pumps	11
1.6	Centrifugal pumps	12
<b>2</b>	<b>Centrifugal Pumps: Design and Construction</b>	<b>19</b>
2.1	Introduction	19
2.2	Impellers	19
2.3	Pump casings	25
2.4	Wearing rings	31
2.5	Shaft	34
2.6	Stuffing boxes	35
2.7	Mechanical seals and seal housings	38
2.8	Bearing housing / bearing isolators	52
2.9	Couplings	56
<b>3</b>	<b>Pump Hydraulics</b>	<b>63</b>
3.1	Introduction	63
3.2	Specific gravity	63
3.3	Viscosity	63
3.4	Vapor pressure	64
3.5	Flow	65
3.6	Head	65
3.7	System resistance	65
3.8	Pump efficiency	68
3.9	Hydraulic power	68
3.10	Pump characteristic curve	68
3.11	Curve corrections	71
3.12	Specific speed	73
3.13	Cavitation, recirculation, and Net Positive Suction Head (NPSH)	77
3.14	Suction specific speed	89
3.15	Performance calculation procedure	90

<b>4</b>	<b>Forces in Centrifugal Pumps</b>	<b>93</b>
4.1	Introduction	93
4.2	Axial thrust	93
4.3	Radial loads	99
<b>5</b>	<b>Centrifugal Pumps: Operation and Characteristics</b>	<b>107</b>
5.1	Introduction	107
5.2	Behavior of hydraulic properties of pumps	108
5.3	Non-dimensional characteristics	113
5.4	The cause of the QH curve	114
5.5	The inlet velocity triangle	115
5.6	What shapes the PQ curve?	116
5.7	The effect of speed changes on characteristic curves	117
5.8	The complete characteristic curve	118
5.9	Multiple pump operation	119
5.10	Pump characteristics - Viscous liquids, liquids with considerable solids	123
5.11	Pump characteristics - Abnormal operation	124
5.12	Pump characteristics – Speed torque curve	125
5.13	Discharge regulation of pumps	129
5.14	Range of pump operation	136
<b>6</b>	<b>Pump Specification and Selection</b>	<b>139</b>
6.1	Introduction	139
6.2	System analysis	140
6.3	Data sheet – The pump specification document	146
6.4	Bid request	147
6.5	Bid review / analysis	147
6.6	Conclusion	149
<b>7</b>	<b>Pump Testing and Inspection</b>	<b>151</b>
7.1	Introduction	151
7.2	Material inspection requirements	152
7.3	Shop tests	154
7.4	Performance test procedure	156



<b>8</b>	<b>Pump Installation and Commissioning</b>	<b>161</b>
8.1	Introduction	161
8.2	Site location	161
8.3	Receipts and physical inspection	162
8.4	Pre-alignment checks	162
8.5	Location of pump foundation	162
8.6	Design and dimensions of pump foundation	163
8.7	Excavation and forms for pump foundation	163
8.8	Rebar and anchor bolts	164
8.9	Pouring	165
8.10	Base plate and sole plate preparation	166
8.11	Grouting	167
8.12	Installation of pump and driver	170
8.13	Associated piping and fittings	171
8.14	On site installation and commissioning of the pump set	174
8.15	Pre-operational checks	175
8.16	Preparation for start-up	175
8.17	Pump in operation	176
<b>9</b>	<b>Centrifugal Pump Maintenance</b>	<b>177</b>
9.1	Introduction	177
9.2	Pump breakdown and removal	181
9.3	Single stage pumps dismantling and repair	181
9.4	Preparation for reassembly	186
9.5	Pump assembly	191
9.6	Vertical pump repair	195
9.7	Multistage pump repair	201
9.8	Optimum time to maintain pumps	205
<b>10</b>	<b>Positive Displacement Pumps</b>	<b>211</b>
10.1	Introduction	211
10.2	Reciprocating pumps	213
10.3	Diaphragm pumps	229
10.4	Rotary pumps	239
10.5	References	278

<b>Appendix A – Pump Types</b>	<b>281</b>
<b>Appendix B – Data Sheets</b>	<b>283</b>
<b>Appendix C – Tutorials (Questions)</b>	<b>285</b>
<b>Appendix D – Answers to Tutorials</b>	<b>321</b>
<b>Appendix E - References</b>	<b>357</b>

---

# 1

---

## Introduction

In this chapter, you will be introduced to different types of centrifugal and positive displacement pumps and their various distinguishing external features such as their construction and components.

### 1.1 Introduction

Transfer of liquids against gravity has occurred from time immemorial. A pump is a device that expends energy to raise, transport, or pressurize liquids. The earliest known pump devices go back to a few thousand years. One such early pump device was called Noria, a water wheel with buckets attached to the rim, used to raise water for transfer to an irrigation channel, similar to the Persian and the Roman waterwheels (see Figure 1.1).



**Figure 1.1**  
*Noria water wheel (From Ripley's Believe it or Nnot)*

Ancient Egyptians invented water wheels with buckets mounted on them to transfer water for irrigation. Over 2000 years ago, Ctesibius, a Greek inventor, made a similar pump for pumping water (Figure 1.2).

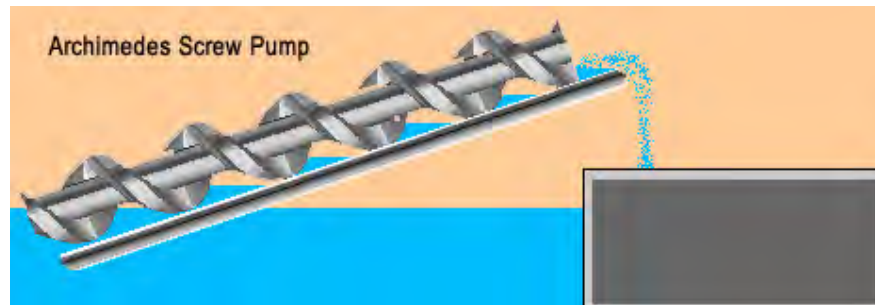

**Figure 1.2**  
*Model of a piston pump made by Ctesibius*

During the same period, Archimedes, a Greek mathematician, invented what is now known as the Archimedes screw — a pump designed like a screw rotating within a cylinder. The spiral tube, set at an incline and hand-operated, was used to drain and irrigate the Nile valley.

In fourth-century Rome, the Archimedes Screw (Figure 1.3), was used for the Roman water supply systems – highly advanced for that time. The Romans also used screw pumps for irrigation and drainage work.

Screw pumps can also be traced to the ore mines of Spain. These early units were all driven by either man or animal power.



**Figure 1.3**  
*Archimedes screw pump*

The mining operations of the Middle Ages led to the development of the suction (piston) pump (Figure 1.4), types of which are described by Georgius Agricola in *De re metallica* (1556). Force pumps, utilizing a piston-and-cylinder combination, were used in Greece to raise water from wells.

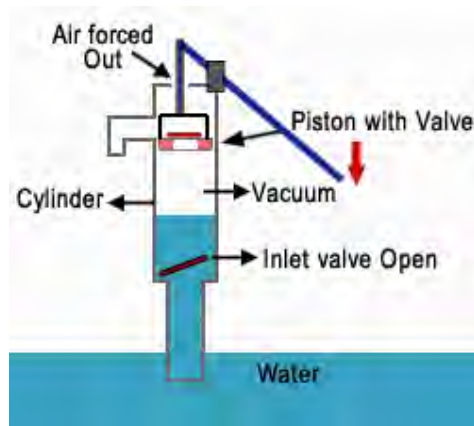

**Figure 1.4**  
*Reciprocating hand pump in suction stroke*

Adopting a similar principle, air pumps operated spectacular musical devices such as the ‘water organ’ in Greek temples and amphitheaters.

## 1.2 Applications

Times have changed, but pumps still operate on the same fundamental principle – expend energy to raise, pressurize and transport liquids. Over time, the application of pumps in the agricultural domain has expanded to cover other areas as well. The following are a few main domains that use pumps extensively:

- **Water Supply** – To supply water to inhabited areas.
- **Drainage** – To control the level of water in a protected area.
- **Sewage** – To collect and treat sewage.
- **Irrigation** – To make dry lands agriculturally productive.
- **Chemical Industry** – To transport fluids to and from various sites in the chemical plant.
- **Petroleum Industry** – Used in every phase of petroleum production, transportation, and refinery.
- **Pharmaceutical and Medical Field** – To transfer of chemicals in drug manufacture; pump fluids in and out of the body.
- **Steel Mills** – To transport cooling water.
- **Construction** – Bypass pumping, well-point dewatering, remediation, general site pumping applications.
- **Mining** – Heavy-duty construction, wash water, pumping of dust control fines and tailings, site dewatering, groundwater control and water runoff.

Pumps are also used for diverse applications ranging from transfer of potatoes to peeling the skin of hazelnuts in chocolate manufacture, and to cut metal sheets in areas that are too hazardous to cut by a gas flame torch. The artificial heart is also a mechanical pump. The heart-lung machines used during open heart surgeries perform the function of the heart using roller pumps.

## 1.3 Types of pumps

Pumps can be classified in various ways. A typical classification of rotating shaft (kinetic) pumps is given in Appendix A

Pumps based on their principle of operation are primarily classified into:

- Positive displacement pumps (reciprocating, plunger type of pumps)
- Roto-dynamic pumps (Centrifugal pumps)
- Other pumps

### 1.3.1 Positive displacement pumps

Positive displacement pumps, which lift a given volume of the fluid for each cycle of operation, can be divided into two main classes, Reciprocating and Rotary.

Reciprocating pumps include piston, plunger, and diaphragm types. Rotary pumps include gear, lobe, screw, vane, peripheral and progressive cavity pumps.

### 1.3.2 Rotodynamic pumps

Rotodynamic pumps, also called Centrifugal pumps, raise the pressure of a liquid by imparting velocity energy to it, and then converting it to pressure energy. Centrifugal pumps include radial, axial, and mixed flow types.

A radial flow pump is commonly referred to as a straight centrifugal pump; the most common type is the volute pump. Fluid enters the pump through the eye of impeller, which is rotating at high speed. The fluid is accelerated *radially* outwards into the pump casing. A partial vacuum is created that continuously draws more fluid into the pump, provided it is properly primed.

In the axial flow centrifugal pumps, the rotor is a propeller, and the fluid flows parallel to the axis of the shaft. In a mixed flow pump, the direction of the liquid from the impeller is between that of the radial and axial flow pumps.

### 1.3.3 Other types of pumps

Many other types of pumps exist, including electromagnetic pumps, jet pumps and hydraulic ram pumps.

## 1.4 Reciprocating pumps

Reciprocating pumps are positive displacement pumps based on the principle of the 2000-year-old pump made by the Greek inventor, Ctesibius.

### 1.4.1 Plunger pumps

Plunger pumps comprise a cylinder with a reciprocating plunger (Figure 1.5). The head of the cylinder houses the suction and the discharge valves.

In the suction stroke, the suction valve opens as the plunger retracts, and the liquid is taken into the cylinder.

In the forward stroke pump, the plunger pushes the liquid forward within the cylinder, which raises the pressure of the liquid. When the liquid pressure in the cylinder exceeds the pressure in the discharge system, the discharge valve opens and allows the liquid to flow from the pump into the system.

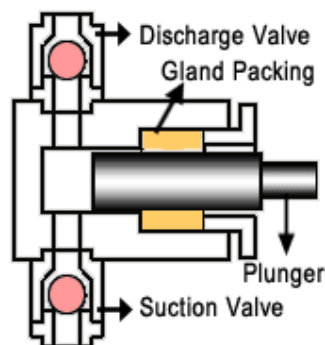

Figure 1.5  
Plunger pump

The gland packings help to contain the pressurized fluid within the cylinder. The plungers are operated using a slider-crank mechanism. Usually two or three cylinders are placed alongside and their plungers derive motion from the same crankshaft. These are called duplex or triplex plunger pumps respectively.

### 1.4.2 Diaphragm pumps

Diaphragm pumps are inherently plunger pumps (Figure 1.6A). The plunger pressurizes the hydraulic oil and this pressurized oil is used to flex the diaphragm. The motion of the diaphragm causes pumping of the process liquid.

Diaphragm pumps are primarily used when the liquids to be pumped are hazardous or toxic. These pumps are often provided with diaphragm rupture indicators.

Diaphragm pumps that are designed to pump hazardous fluids usually have a double diaphragm, separated by a thin film of liquid which must be compatible to the pumped liquid (Figure 1.6B). A pressure sensor gauges the pressure of this liquid. Under normal conditions, the pressure on the process and oil sides of the diaphragms is always the same and the pressure between the diaphragms is zero.

However, as soon as one of the diaphragms ruptures, the pressure sensor records a maximum of process discharge pressure. The rising of this pressure is an indicator of the diaphragm rupture.



**Figure 1.6A**  
*Diaphragm pump*

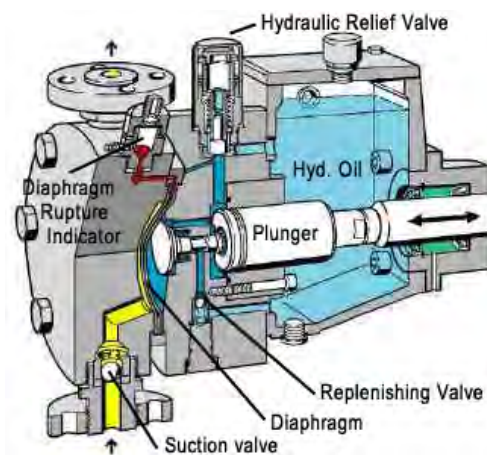
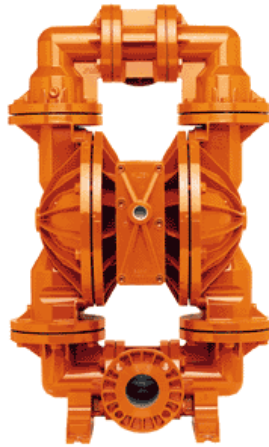

**Figure 1.6B**  
*Double diaphragm pumps (Lewa Pumps)*

Even with the rupture of one diaphragm, the process liquid does not come into contact with the atmosphere.

### 1.4.3 Air-operated diaphragm pumps

Air-operated Diaphragm pumps (Figure 1.6C) are a variation of the diaphragm/double diaphragm pumps. These are flexed back and forth by compressed air. This allows these pumps to be used where electric drives are considered unsafe. For example, these may be installed in areas where hazardous or explosive gases may be present. These pumps are self-priming, can run dry for brief periods, and can handle hazardous liquids of high viscosity. Another utility is that it can pump solids up to certain sizes.



**Figure 1.6C**  
*Air-operated diaphragm pump*

### 1.4.4 Positive displacement pumps (Rotary)

Gear pumps are of two types:

- External Gear Pump
- Internal Gear Pump

#### External gear pump

In external gear pumps, two identical gears rotate against each other (Figure 1.7). The motor provides the drive for one gear. This gear in turn drives the other gear. A separate shaft supports each gear, which contains bearings on both its sides.

As the gears come out of the mesh, they create expanding volume on the inlet side of the pump. The liquid flows into the cavity and is trapped by the gear teeth and pump casing while they rotate.

The liquid travels around the interior of the casing in the pockets between the teeth and the casing. The fine side clearances between the gear and the casing minimize recirculation of the liquid between the gears and between gears and the casing.



**Figure 1.7**  
*External gear pump*



Finally, the meshing of the gears forces the liquid through the outlet port under pressure. As the gears are supported on both sides, the noise levels of these pumps are lower and are typically used for high-pressure applications such as hydraulic systems.

### Internal gear pump

Internal gear pumps (Figure 1.8) have only two moving parts. They can operate in either direction, which allows maximum utility with a variety of application requirements.

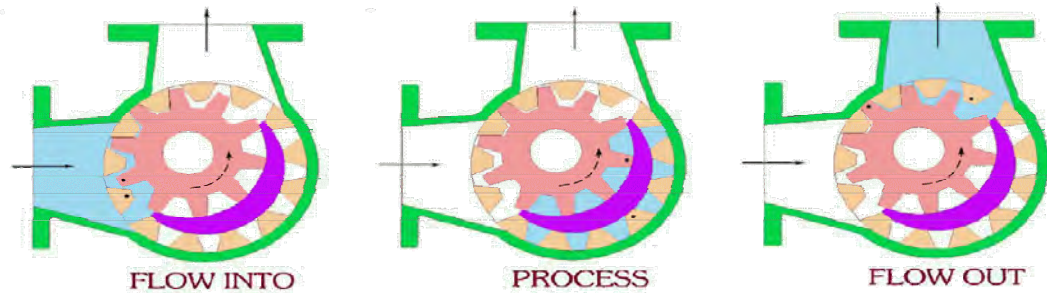

**Figure 1.8**  
*Internal gear pump*

In these pumps, the liquid enters the suction port between the large exterior gear (called the rotor) and the idler (the smaller interior gear teeth.) The arrows indicate the direction of the pump rotation and the flow of the liquid.

The liquid travels through the pump between the gear teeth, obeying the “gear-within-a-gear” principle. The crescent shape divides the liquid and acts as a seal between the suction and the discharge ports.

The pump head is now nearly flooded as it forces the liquid out of the discharge port. Rotor and idler teeth mesh completely to form a seal equidistant from the discharge and suction ports. This seal forces the liquid out of the discharge port.

The internal gear pumps are capable of handling liquids with very low to very high viscosities. In addition to superior high-viscosity handling capabilities, internal gear pumps offer a smooth, non-pulsating flow. Internal gear pumps are self-priming and can run dry.

The operation of the lobe pumps shown in Figure 1.9 is similar to the operation of the external gear pumps. Here, each of the lobes is driven by external timing gears. As a result, the lobes do not make contact.

Bearings supporting the pump shafts are located in the gearbox. Since the bearings are not within the pumped liquid, pressure is limited by the location of the bearing and shaft deflection.

As the lobes come out of mesh, they create an expanding volume on the inlet side of the pump. The liquid then flows into the cavity and is trapped by the lobes as they rotate.

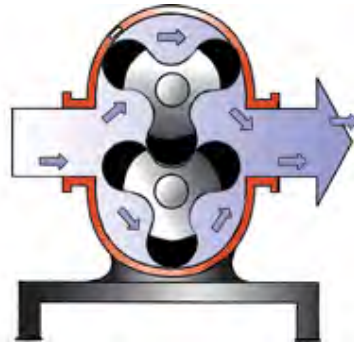

**Figure 1.9**  
*Lobe pump*

The liquid travels around the interior of the casing in the pockets between the lobes and the casing and it does not pass between the lobes.

Finally, the meshing of the lobes forces the liquid through the outlet port under pressure. Lobe pumps are frequently used in food applications because they can handle solids without damaging the product. The size of particle pumped can be much larger in lobe pumps than in any other of the PD types.

A vane pump, too, traps the liquid by forming a compartment comprising vanes and the casing (Figure 1.10). As the rotor turns, the trapped liquid is traversed from the suction port to the discharge port.

A slotted rotor or impeller is eccentrically supported in a cycloidal cam. The rotor is located close to the wall of the cam to form a crescent-shaped cavity. The rotor is sealed into the cam by two side plates. Vanes or blades fit in the slots of the impeller. As the impeller rotates and the fluid enters the pump, centrifugal force, hydraulic pressure springs, and/or pushrods push the vanes to the walls of the housing. The tight seal among the vanes, rotor, cam, and side plate is the key to good suction — the common vane pumping principle.

The housing and cam force the fluid into the pumping chamber through holes in the cam. The fluid enters the pockets created by the vanes, rotor, cam, and side plate.

As the impeller rotates, the vanes sweep the fluid to the opposite side of the crescent where it is squeezed through the discharge holes of the cam as the vane approaches the point of the crescent. The fluid then exits the discharge port.

Vane pumps are ideally suited for low-viscosity, non-lubricating liquids.

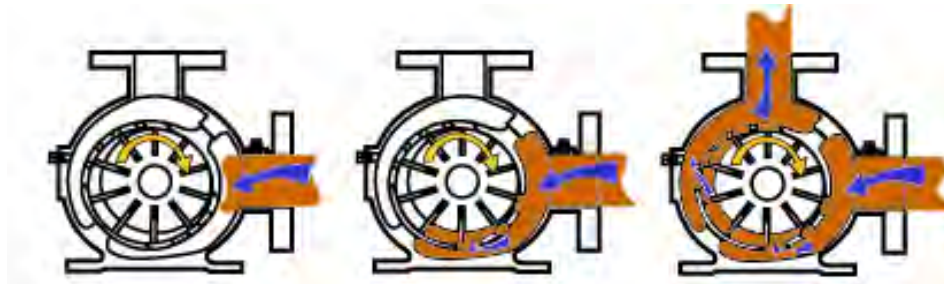

**Figure 1.10**  
*Vane pump*

The impeller of the Flexible Rotor pump is made of flexible material. Each vane begins to flex as it moves up the eccentric at the centre of the discharge hole, and flexing extends along the whole vane length as it moves away from the eccentric after passing through the inlet port. Increasing the

volume between two adjacent vanes at the inlet port produces a vacuum which leads the fluid to circulate towards the larger space. Reducing the volume at the discharge port forces the fluid out through the discharge tube (see Figure 1.11).



**Figure 1.11**  
*Flexible rotor pump*

Flexible impeller pumps are used for viscous fluids which cannot be handled by centrifugal pumps. They are also used for highly abrasive fluids which require hardened contact surfaces on the rotary elements.

A progressive cavity pump as shown in Figure 1.12 consists of only one basic moving part, which is the driven metal rotor rotating within an elastomer-lined (elastic) stator.

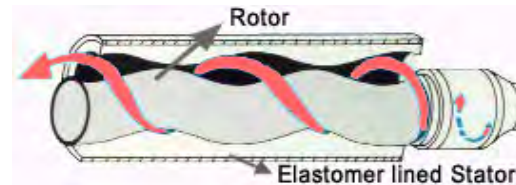

**Figure 1.12**  
*Progressive cavity pump*

As the rotor turns, chambers are formed between the rotor and stator. These chambers progress axially from the suction to the discharge end, moving the fluid. By increasing the pitch of the rotor and stator, additional chambers or stages are formed.

These pumps have solved the special pumping problems of municipal and industrial wastewater and waste processing operations. Industries such as chemical, petrochemical, food, paper and pulp, construction, mining, cosmetic and industrial finishing find these pumps ideally suited for pumping fluids with non-abrasive material inclusion.

As shown in Figure 1.13, the impeller has a large number of small radial vanes on both sides. The impeller runs in a concentric circular casing. The fluid enters between two impeller vanes and is set into a circular motion; this adds energy to the fluid that travels in a spiral-like path from the inlet to the outlet. Each set of vanes continuously adds energy to the fluid particles.

Peripheral pumps are more efficient than centrifugal pumps at low flow, high head conditions. They have a lower NPSHr than an equivalent centrifugal pump. They can also handle liquids with up to 20% entrained gases.

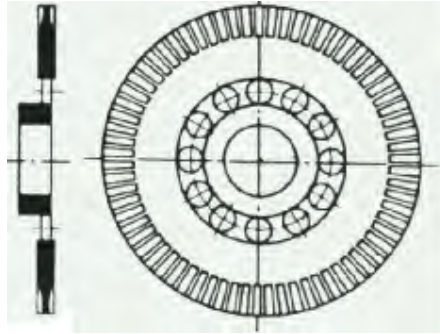

**Figure 1.13**  
*Peripheral pump impeller*

In addition to the previously described pumps based on the Archimedes Screw, there are pumps fitted with two or three spindle screws housed in a casing. Pumps with a twin screw design, mesh with close clearances and are mounted on parallel shafts. Drive is given to one shaft and through timing gears, drive is transmitted to the other. They are usually of a finer pitch compared to the three-screw design. The screws have opposite hand threads.

Three-spindle screw pumps (Figure 1.14) are ideally suited for a variety of marine and offshore applications such as fuel-injection, oil burners, boosting, hydraulics, fuel, lubrication, circulating, feed and many more. While pumping such liquids, timing gears may be absent and the central screw may directly drive the other two screws. The pumps deliver pulsation-free flow with low noise levels. They are self-priming with high efficiency. They are also ideal for highly viscous liquids.

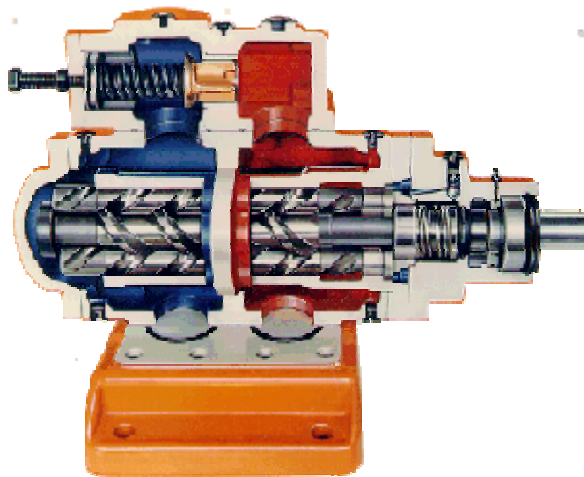

**Figure 1.14**  
*Three-spindle screw pump – Alweiller pumps*

Peristaltic Pumps use a turning mechanism to move media through a tube (see Figure 1.15). The tube is compressed at a number of points in contact with the rollers or shoes. The media is moved through the tube with each rotating motion. The fluid does not contact any internal parts. Seals and valves are not needed as in other pumps. Peristaltic pumps are used in hospitals and pharmaceutical, chemical, and food and beverage applications.

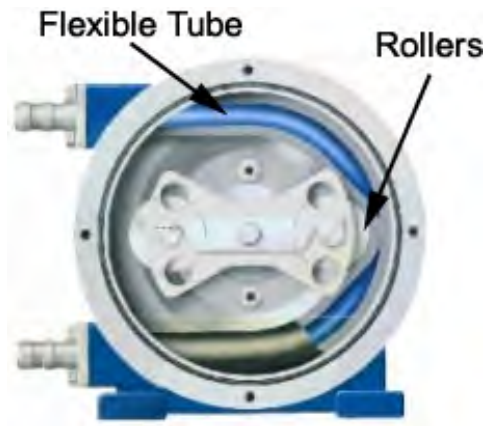

**Figure 1.15**  
*Roller or peristaltic pump*

## 1.5 Other types of pumps

### 1.5.1 Electromagnetic pump

Electromagnetic pumps operate on the principle that a force is exerted on a current-carrying conductor in a magnetic field. These can be used only when the fluid is a conductor of electricity. When liquid metals with high electrical conductivity are pumped (as in nuclear applications), a pumping force develops within the metals when they are confined in a duct or channel and subjected to a magnetic field and to an electric current.

Other metallic and nonmetallic liquids with good electrical conductivity, such as mercury or molten aluminum, lead, and bismuth can be pumped in non-nuclear applications. The absence of moving parts within the pumped liquid eliminates the need for seals and bearings as in conventional pumps, thus improving reliability.

### 1.5.2 Jet pumps

Jet pumps work on the principle of an ejector. A centrifugal pump is used in conjunction with a venturi. The high pressure liquid from the centrifugal pump is made to pass through the nozzle of the venturi. The jet thus formed creates a low pressure area at its throat. This low pressure area is used to enhance the suction capacity of the pump. Its typical application is to pump out water from shallow and deep wells. Often used in place of submersible pumps, it has poor efficiency.

### 1.5.3 Hydraulic ram pump

Ram pumps need no external source of power and have a relatively simple construction. The principle behind a ram pump is that it uses the momentum of a relatively large amount of moving fluid to pump a relatively small amount of fluid to a much higher gradient.

A ram pump needs a large source of water above the pump. Water is led through a pipe from the source to the pump. The pump has a valve in the pipe that allows water to flow and build up momentum. Once the water reaches its maximum momentum, this valve slams shut. Now the flowing water develops a great deal of pressure in the pump because of its inertia, which forces open a second valve. Water under high pressure flows through the second valve to the discharge pipe. The discharge pipe has an air chamber to allow the discharge pipe to collect as much high-pressure water as possible during the impulse. When the pressure in the pump falls, the first valve re-opens to allow water to flow and build up momentum again. Now the second valve closes, and the cycle repeats itself. The discharge pipe can rise some distance above both the pump and the source of the water. If the pump was located three meters below the source, it could lift the water to nearly 30 meters.

## 1.6 Centrifugal pumps

The centrifugal pumps are by far the most commonly used of all the pump types. Amongst all the installed pumps in a typical petroleum plant, almost 80 to 90% are centrifugal pumps. Centrifugal pumps are widely used because of their design simplicity, high efficiency, wide capacity and head ranges, smooth flow rate, and ease of operation and maintenance.

The “modern” era pumps began during the late 17th and early 18th centuries. British engineer Thomas Savery, French physicist Denis Papin, and British blacksmith and inventor Thomas Newcomen contributed to the development of a water pump that used steam to power the pump’s piston. The steam-powered water pump’s first wide use was in pumping water out of mines.

The origin of the centrifugal impeller is attributed to French physicist and inventor Denis Papin in 1689, shown in Figure 1.16.

Papin’s contribution lies in his understanding of the concept of creating a forced vortex within a circular or spiral casing by means of blades. The pump he made had straight vanes.

Following Papin’s theory, Combs presented a concept in 1838 on curved vanes and the effect of curvature, which subsequently proved to be an important factor in the development of the centrifugal impeller. In 1839, W.H. Andrews introduced the proper volute casing and in 1846, he used a fully shrouded impeller.



**Figure 1.16**  
*Denis Papin*

In 1846, W.H. Johnson constructed the first three-stage centrifugal pump. James S. Gwynne constructed a multistage centrifugal pump in 1849 and began the first systematic examination of these pumps.

Around the same time, British inventor John Appold conducted an exhaustive series of empirically directed experiments to determine the best shape of the impeller, which led to his discovery that efficiency depends on blade curvature. Appold’s pump of 1851, with curved blades showed an efficiency of 68%, improving pump efficiency three-fold.

The subsequent development of the centrifugal pump was very rapid due to its relatively inexpensive manufacture and its ability to handle voluminous amounts of fluid. However, it has to be noted that the popularity of the centrifugal pump has been made possible by major developments in the fields of electric motors, steam turbines and internal combustion engines. Prior to this, positive displacement type pumps were more widely used.



The centrifugal pump has a simple construction, essentially comprising a volute (1) and an impeller (2). Refer to Figure 1.17. The impeller is mounted on a shaft (5), which is supported by bearings (7) assembled in a bearing housing (6). A drive coupling is mounted on the free end of the shaft.

The prime mover, which is usually an electrical motor, steam turbine or an IC engine, transmits the torque through the coupling.

As the impeller rotates, it accelerates and displaces the fluid within itself, and more fluid is drawn into the impeller to take its place if the pump is properly primed. Thus, the impeller imparts kinetic or velocity energy to the fluid through mechanical action. This velocity energy is then converted to pressure energy by the volute. The pressure of the fluid formed in the casing has to be contained. This is achieved by an appropriate sealing arrangement (4). The seals are installed in the seal housing (3).

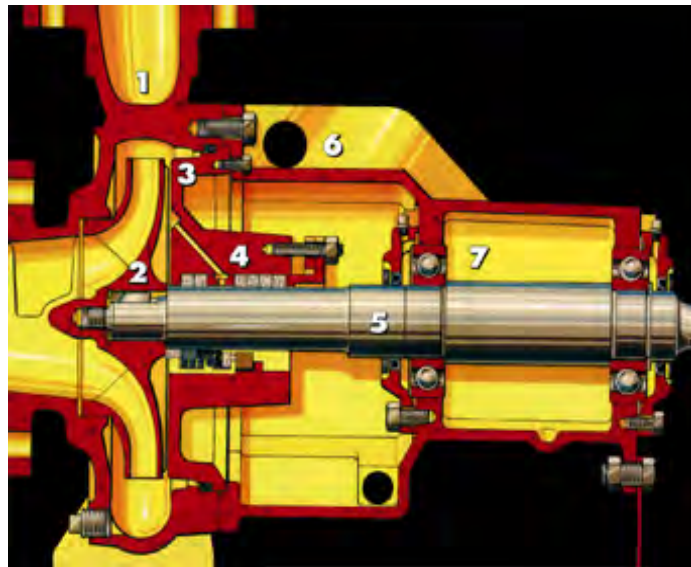

**Figure 1.17**  
*Centrifugal pump – basic construction*

The normal operating speed of pumps is 1500 rpm (1800 rpm) and 3000 rpm (3600 rpm). However, there are certain designs of pumps that operate at speeds in the range from 5000 rpm to excess of 25000 rpm.

### 1.6.1 Types of centrifugal pumps

Centrifugal pumps can be classified on the basis of various factors. Some of the main ways of classification are:

#### Orientation of the pump shaft axis

This factor refers to the plane on which the shaft axis of the pump is placed. It is either horizontal or vertical as shown in Figure 1.18.

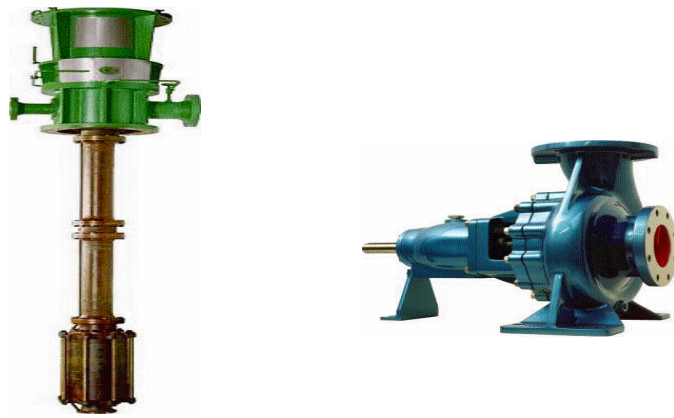

**Figure 1.18**  
*Vertical pump and horizontal pump*

### Number of stages

This refers to the number of sets of impellers and diffusers in a pump. A set forms a stage and it is usually single, dual or multiple (more than two) stages. Figure 1.19 shows the multistage pump.

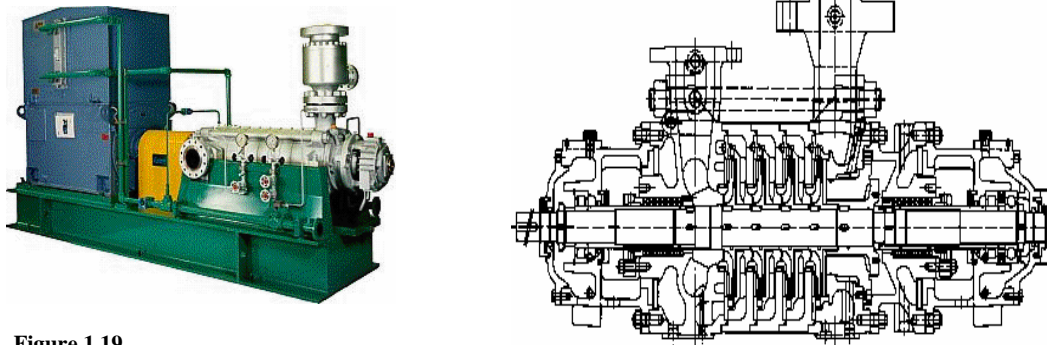

**Figure 1.19**  
*Multistage pump*

### Suction flange orientation

This is based on the orientation of the pump suction flange. This orientation could be horizontal (also known as End) or vertical (also known as Top). Figure 1.20 shows a multistage pump with end suction.

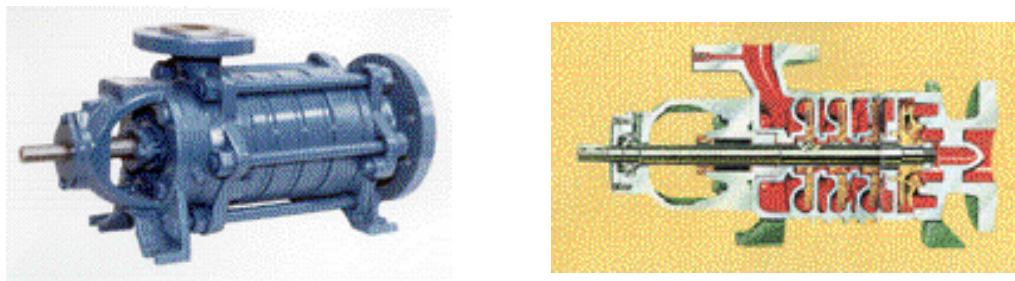

**Figure 1.20**  
*Multistage pump with end suction*



### Casing split

This classification is based on the casing split. It is either Radial (perpendicular to shaft axis) or Axial (plane of the shaft axis) (shown in Figure 1.21).



**Figure 1.21**  
*Axial split casing*

**Bearing support** This support is judged based on the location of the bearings supporting the rotor. If the rotor is supported in the form of a cantilever, it is called an *Overhung* type of pump. When the impellers on the rotor are supported with bearings on either side, the pump is called an *In-between bearings* pump.

### Pump support

This factor indicates how the pump casing is supported on the base frame. It could be a center-line (Figure 1.22A) support or foot-mounted support (Figure 1.22B).



A



B

**Figure 1.22**  
*Models of pump supports*

### Shaft connection

The closed coupled pumps (Figure 1.23) are characterized by the absence of a coupling between the motor and the pump. The motor shaft has an extended length and the impeller is mounted on one end.



**Figure 1.23**  
*Closed coupled monobloc pumps with end suction*

The vertical monobloc pumps have the suction and discharge flanges along one axis and can be mounted between pipelines. They are also termed “in-line” pumps.

## Sealless pumps

Pumps are used to build the pressure in a liquid, and to contain it within the casing if necessary. At the interface of the rotating shaft and the pump casing, a sealing system is installed to do the job of product containment. These are prone to leakage and may be unacceptable in certain critical applications. To address this issue, there are sealless pumps.

These are of two types – canned and magnetic drive pumps:

- **Canned pumps**

In the construction of this type of sealless pump, the rotor comprises of an impeller, shaft, and the rotor of the motor (Figure 1.24). These are housed within the pump casing and a containment shell. The hazardous or the toxic liquid is confined within this shell and casing.

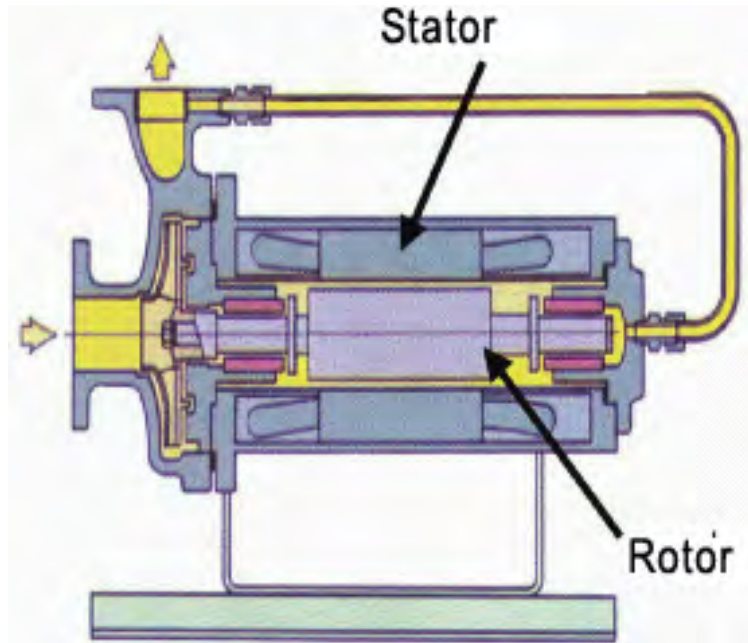

**Figure 1.24**  
*Canned pump*

The rotating flux generated by the stator passes through the containment shell and drives the rotor and the impeller.

- **Magnetic drive pumps**

In magnetic drive pumps, the rotor comprises an impeller, a shaft, and driven magnets housed within the pump casing and containment shell (Figure 1.25). They ensure that the usually hazardous/toxic liquid is contained within a metal shell.

The driven magnets take their drive from the rotating drive magnets, which are assembled on a different shaft that is coupled to the prime mover.

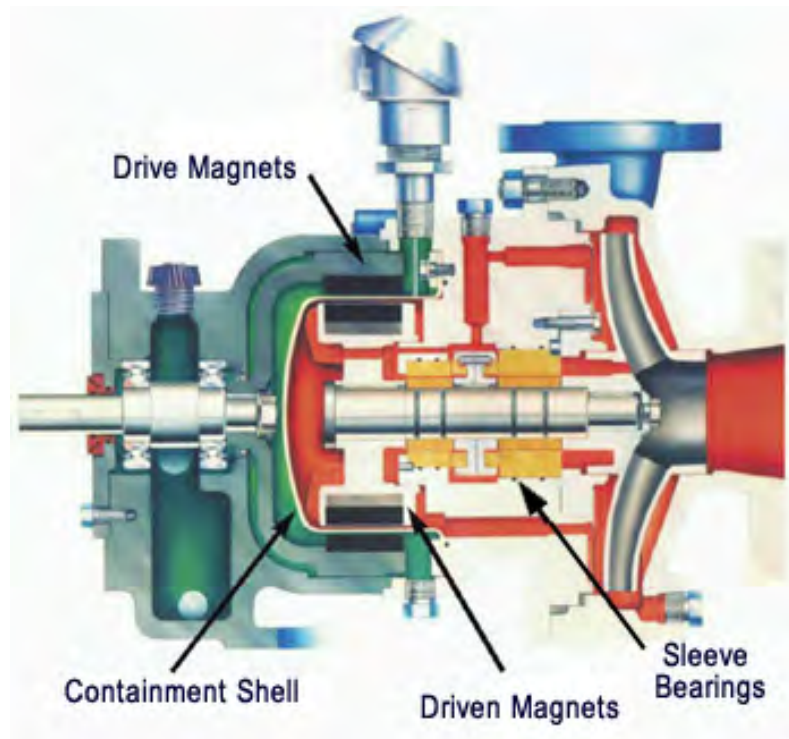

**Figure 1.25**  
Magnetic

*drive pump*

### Pump standards

A number of centrifugal pump standards have been developed to bring about uniformity and minimum standards of design and dimensional specifications. These include the API (American Petroleum Institute), ISO (International Standards Organization), ANSI (American National Standards Institute), DIN (German), NFPA (Nation Fire Protection Agency), and AS-NZ (Australia–New Zealand).

Some of the most common standards, which are used in the development and manufacture of centrifugal pumps are API-610, ISO-5199, 2858, ANSI B73.1, DIN 24256, NFPA-21.

In addition to the above, there are many National Standards. Some of these are:

- France – NF E 44.121
- United Kingdom – BS 5257
- German – DIN 24256
- Australia & New Zealand – AS 2417-2001, grades 1 and 2.

Usually, the service criticality or application of the pump forms the deciding factor for the choice of standard. A critical refinery pump handling hazardous hydrocarbons would in all probability be built as per standard API-610. A pump built to API-610 standard is shown in Figure 1.26.



**Figure 1.26**  
*Pump built to API-610 standard*

However, ordinary applications do not require the entire API specified features and the premium that comes with an API pump is not justified. Pumps built to lesser demanding standards like the ANSI B73.1 can be used for such applications. A big advantage of ANSI pumps is the outline dimensional interchangeability of pumps of the same size regardless of brand or manufacturer, something that is not available in the API pumps.

In a similar way, pumps meant for firewater applications are usually built to the design specifications laid out in NFPA-21.

There are some standards like the ISO 2858 that are primarily dimensional standards. This does not stipulate any requirement for the pump's construction. The standard from ISO that addresses the design aspects of pumps is ISO 5199.

For a good comparative study of the API, ANSI, and ISO standards, a technical paper entitled *ISO-5199 Standard Addresses Today's Reliability Requirements for Chemical Process Pumps*, by Pierre H. Fabeck and R. Barry Erickson is recommended. This paper was presented at the Seventh Pumps Symposium (1990) at Texas A&M University.

### Pump applications

The classification of pumps in the above sections is based on the construction of the pump and its components. However, based on the applications for which they are designed, pumps tend to be built differently.

Some of the applications where typical pumps can be found are:

- Petroleum and Chemical Process Pumps
- Electric, Nuclear Power Pumps
- Waste / Wastewater, Cooling Tower pumps
- Pulp and Paper
- Mining Industry slurries
- Pipeline, Water-flood (injection) pumps

As this needs an introduction to the components/construction of the pump these are covered in detail in subsequent chapters.