



Technology Training that Works

Presents

**Operation and Maintenance of
Diesel Power
Generating Plants**

www.idc-online.com
idc@idc-online.com



Technology Training that Works

Copyright

All rights to this publication, associated software and workshop are reserved. No part of this publication or associated software may be copied, reproduced, transmitted or stored in any form or by any means (including electronic, mechanical, photocopying, recording or otherwise) without prior written permission of IDC Technologies.

Disclaimer

Whilst all reasonable care has been taken to ensure that the descriptions, opinions, programs, listings, software and diagrams are accurate and workable, IDC Technologies do not accept any legal responsibility or liability to any person, organization or other entity for any direct loss, consequential loss or damage, however caused, that may be suffered as a result of the use of this publication or the associated workshop and software.

In case of any uncertainty, we recommend that you contact IDC Technologies for clarification or assistance.

Trademarks

All terms noted in this publication that are believed to be registered trademarks or trademarks are listed below:

IBM, XT and AT are registered trademarks of International Business Machines Corporation. Microsoft, MS-DOS and Windows are registered trademarks of Microsoft Corporation.

Acknowledgements

IDC Technologies expresses its sincere thanks to all those engineers and technicians on our training workshops who freely made available their expertise in preparing this manual.

Who is IDC Technologies?

IDC Technologies is a specialist in the field of industrial communications, telecommunications, automation and control and has been providing high quality training for more than eight years on an international basis from offices around the world.

IDC consists of an enthusiastic team of professional engineers and support staff who are committed to providing the highest quality in their consulting and training services.

The Benefits to you of Technical Training Today

The technological world today presents tremendous challenges to engineers, scientists and technicians in keeping up to date and taking advantage of the latest developments in the key technology areas.

The immediate benefits of attending IDC workshops are:

- Gain practical hands-on experience
- Enhance your expertise and credibility
- Save \$\$\$s for your company
- Obtain state of the art knowledge for your company
- Learn new approaches to troubleshooting
- Improve your future career prospects

The IDC Approach to Training

All workshops have been carefully structured to ensure that attendees gain maximum benefits. A combination of carefully designed training software, hardware and well written documentation, together with multimedia techniques ensure that the workshops are presented in an interesting, stimulating and logical fashion.

IDC has structured a number of workshops to cover the major areas of technology. These courses are presented by instructors who are experts in their fields, and have been attended by thousands of engineers, technicians and scientists worldwide (over 11,000 in the past two years), who have given excellent reviews. The IDC team of professional engineers is constantly reviewing the workshops and talking to industry leaders in these fields, thus keeping the workshops topical and up to date.

Technical Training Workshops

IDC is continually developing high quality state of the art workshops aimed at assisting engineers, technicians and scientists. Current workshops include:

Instrumentation, Automation and Process Control

Practical Programmable Logic Controllers (PLC's) for Automation and Process Control
Practical Data Acquisition using Personal Computers and Standalone Systems
Practical Analytical Instrumentation in On-Line Applications
Practical Industrial Flow Measurement for Engineers and Technicians
Practical Intrinsic Safety for Engineers and Technicians
Practical Safety Instrumentation and Shut-down Systems for Industry
Practical Process Control for Engineers and Technicians
Practical Programming for Industrial Control - using IEC 1131-3 and OPC
Practical SCADA and Telemetry Systems for Industry
Practical Boiler Control and Instrumentation for Engineers and Technicians
Practical Instrumentation for Automation and Process Control
Practical Motion Control for Engineers and Technicians
Practical Automation Systems: A Primer for Managers
Practical Batch Management and Control (Including S88) for Industry
Practical Hazardous Areas for Electrical Equipment
Practical Tuning of Industrial Control Loops

Data Communications and Networking

Practical Data Communications for Instrumentation and Control
Practical Troubleshooting TCP/IP Networks
Practical FieldBus and Device Networks for Engineers and Technicians
Practical Industrial Communication Protocols
Practical Fibre Optics for Engineers and Technicians
Practical Industrial Networking: Ethernet in Practice
Practical TCP/IP and Ethernet Networking for Industry

Practical Telecommunications for Engineers and Technicians

Practical Local Area Networks for Engineers and Technicians
Practical Wireless and Mobile Radio Systems for Industry
Practical Use and Understanding of Foundation FieldBus for Engineers and Technicians
Working with and Troubleshooting of TCP/IP Networks
Practical Troubleshooting and Problem Solving of Industrial Data Communication Systems
Practical DNP 3.0 and Modern SCADA Communication Systems

IT (Information Technology)

Practical Essentials for NT 4.X
Practical Support of Windows NT 4.x Servers
Practical Web-Site Development and E-Commerce Systems for Industry
Personal Computer and Network Security (Protect from Hackers, Crackers & Viruses)
Practical Guide to MCSE Certification - NT or 2000 exam entry level
Practical Application Development for Web Based SCADA
Practical TCP/IP, Troubleshooting and Problem Solving for Industry
Professionals SNMP Network Management: The Essentials

Electrical Power

Practical Power System Protection for Engineers and Technicians
Practical High Voltage Safety Operating Procedures for Engineers and Technicians
Practical Power Quality: Problems and Solutions
Practical Electrical Network Automation and Communication Systems
Practical Power Distribution
Practical Variable Speed Drives for Instrumentation and Control Systems
Practical Earthing, Bonding, Lightning and Surge Protection of Electrical and Electronic Systems and Equipment

Electronics

Practical Digital Signal Processing Systems for Engineers and Technicians
Practical Industrial Electronics for Engineers and Technicians
Practical Image Processing and Applications
Practical EMC and EMI Control for Engineers and Technicians
Practical Embedded Controllers: Troubleshooting and Design

Project and Financial Management

Practical Project Management for Engineers and Technicians
Practical Financial Management and Project Investment Analysis
How to Manage Consultants
Practical Technical Writing for Engineers and Technicians
Marketing for Engineers and Technical Personnel

Mechanical Engineering

Practical Boiler Plant Operation and Management for Engineers and Technicians
Practical Centrifugal Pumps - Optimising Performance
Practical Clean Room Technology and Facilities for Engineers and Technicians
Practical Operation and Troubleshooting of Hydraulic Systems
Practical Vibration Analysis and Predictive Maintenance
Practical Fundamentals of Air-Conditioning and Refrigeration

Miscellaneous Engineering

Practical Fundamentals of Chemical Engineering

Comprehensive Training Materials

Workshop Documentation

All IDC workshops are fully documented with complete reference materials including comprehensive manuals and practical reference guides.

Software

Relevant software is supplied with most workshops. The software consists of demonstration programs which illustrate the basic theory as well as the more difficult concepts of the workshop.

Hands-On Approach to Training

The IDC engineers have developed the workshops based on the practical consulting expertise that has been built up over the years in various specialist areas. The objective of training today is to gain knowledge and experience in the latest developments in technology through cost effective methods. The investment in training made by companies and individuals is growing each year as the need to keep topical and up to date in the industry which they are operating is recognized. As a result, the IDC instructors place particular emphasis on the practical, hands-on aspect of the workshops presented.

On-Site Workshops

In addition to the quality of workshops which IDC presents on a world-wide basis, all IDC workshops are also available for on-site (in-house) presentation at our clients' premises.

On-site training is a cost effective method of training for companies with many delegates to train in a particular area. Organizations can save valuable training \$\$\$'s by holding workshops on-site, where costs are significantly less. Other benefits are IDC's ability to focus on particular systems and equipment so that attendees obtain only the greatest benefits from the training.

All on-site workshops are tailored to meet with clients training requirements and workshops can be presented at beginners, intermediate or advanced levels based on the knowledge and experience of delegates in attendance. Specific areas of interest to the client can also be covered in more detail.

Our external workshops are planned well in advance and you should contact us as early as possible if you require on-site/customized training. While we will always endeavor to meet your timetable preferences, two to three months notice is preferable in order to successfully fulfil your requirements.

Please don't hesitate to contact us if you would like to discuss your training needs.

Customized Training

In addition to standard on-site training, IDC specializes in customized courses to meet client training specifications. IDC has the necessary engineering and training expertise and resources to work closely with clients in preparing and presenting specialized courses.

These courses may comprise a combination of all IDC workshops along with additional topics and subjects that are required. The benefits to companies in using training are reflected in the increased efficiency of their operations and equipment.

Training Contracts

IDC also specializes in establishing training contracts with companies who require ongoing training for their employees. These contracts can be established over a given period of time and special fees are negotiated with clients based on their requirements. Where possible, IDC will also adapt workshops to satisfy your training budget.

References from various international companies to whom IDC is contracted to provide on-going technical training are available on request.

Some of the thousands of Companies world-wide that have supported and benefited from IDC workshops are:

- Alcoa
- Allen-Bradley
- Altona Petrochemical
- Aluminum Company of America
- AMC Mineral Sands
- Amgen
- Arco Oil and Gas
- Argyle Diamond Mine
- Associated Pulp and Paper Mill
- Bailey Controls
- Bechtel
- BHP Engineering
- Caltex Refining
- Canon
- Chevron
- Coca-Cola
- Colgate-Palmolive
- Conoco Inc
- Dow Chemical
- ESKOM
- Exxon
- Ford
- Gillette Company
- Honda
- Honeywell
- Kodak
- Lever Brothers
- McDonnell Douglas
- Mobil
- Modicon
- Monsanto
- Motorola
- Nabisco
- NASA
- National Instruments
- National Semi-Conductor
- Omron Electric
- Pacific Power
- Pirelli Cables
- Proctor and Gamble
- Robert Bosch Corp
- Siemens
- Smith Kline Beecham
- Square D
- Texaco
- Varian
- Warner Lambert
- Woodside Offshore Petroleum
- Zener Electric

Preface

Most industries relying on electric power for their operation prefer to source their electrical supply from the local power utility grid. But those who require a reliable alternate source of power opt for an in-plant generating source to ensure an adequate backup to the grid supply. This has become an issue even in countries where reliable power has normally been taken for granted. As the complexity of power grids increases, instances of cascaded tripping and total system collapse seem to be happening more frequently than ever before.

There are several options for establishing an in-plant power backup source. Generating sets with a diesel engine as the prime mover is one of the most preferred options in industries today, particularly in those industries where prolonged power outages may cause equipment damage, create unsafe conditions, require long process restarting time, and result in extensive disruption of production and consequently failed delivery schedules and loss of customer goodwill.

In addition, most power utilities themselves set up generating plants based on diesel engines for various purposes. These include: meeting peak power demands by having generating sets which can be started and brought in quickly; having a reliable self-starting power source to restart other conventional steam generating plants (which always require another power source for start-up); as a critical power source to prevent equipment damage/unsafe conditions in large conventional generating plants and ensure safe plant shutdown during major grid outages, and so on.

In this book, we will deal with the fundamentals of diesel engines and engine-based power generating sets. We will discuss various liquid and gaseous fuel options available and fuel storage requirements for different fuels. We will cover the principles involved in planning the plant layout for a typical diesel power generating station. We will also touch upon the care and maintenance of diesel generating plant equipment and various tests that need to be performed right from the acceptance of equipment at the supplier's works, to commissioning tests and further periodic tests during the plant operational phase.

People who will find this book useful include:

- Consulting Engineers
- Electrical Engineers
- Utility engineers
- Data Systems Planners and Managers planning standby generation capacity
- Building Service Designers
- Power System Engineers
- Maintenance Engineers
- Electrical Inspectors
- Electrical Contractors
- Electricians

You will gain knowledge on the following:

- The basics of electricity generation
- Internal combustion engines as prime movers
- Diesel engines as a versatile prime mover for energy generation
- Fuels used in Diesel power generating plants
- Generators and engine-generator assemblies
- Layout configurations of engine based power plants
- Testing and commissioning
- Operation and maintenance

We assume basic electrical engineering knowledge as well as some preliminary knowledge of power generation and use. However, the subject is dealt with from fundamentals and therefore even those with no exposure or experience in these specific topics should be able to understand the issues and be able to apply them to their work needs.

Table of Contents

1	Introduction	1
1.1	Energy sources	1
1.2	AC and DC power	3
1.3	Single phase and three-phase AC power	3
1.4	Prime movers	6
1.5	Power plant components/types	11
1.6	Engine types	13
1.7	Diesel power plants	15
1.8	Advantages of Diesel power generation	18
1.9	Summary	19
2	Engine Technology and Classifications	21
2.1	Engine Processes	21
2.2	Reciprocating Engines	22
2.3	Types of Ignition Engines	25
2.4	Spark and Compression Engines - Comparison	29
2.5	Dual Fuel Engines	32
2.6	Fuels used in engines	33
2.7	Speed Classifications	35
2.8	Service Classifications	36
2.9	Summary	38
3	Engine Design and ISO Ratings	39
3.1	Design Characteristics	39
3.2	Basic Formulae	41
3.3	Ambient Conditions on Performance	43
3.4	Turbocharger Schemes	43
3.5	Jacket Water Heating System	46
3.6	ISO Standards	47
3.7	Performance and Efficiency Enhancements	49
3.8	Summary	50
4	Fuels for DG sets and Fuel oil system	51
4.1	Fuels in Power Plants	51

4.2	Crude oil (CRO)	52
4.3	Diesel fuel	54
4.4	Economics of fuel selection	56
4.5	Typical pressure and temperatures of the CRO system	56
4.6	Viscosity	59
4.7	Density and Temperature	61
4.8	Specific Heat and Temperature	61
4.9	Viscosity conversion	62
4.10	Fuel Filters	63
4.11	Fuel nozzles and igniters	65
4.12	Emission Control	66
4.13	Storage Requirements	67
4.14	System layouts	67
4.15	Summary	69

5 Lube oils and lubrication systems of Diesel engines 71

5.1	Lube oil functions and definitions	71
5.2	Lube oil Specifications	72
5.3	Lube Oil Types	75
5.4	Lubrication system schematics	76
5.5	Viscosity Temperature Conversion	78
5.6	Summary	80

6 Generators 83

6.1	Principle of operation	83
6.2	Generator Components	89
6.3	AC Generator Types	91
6.4	Generator Construction	92
6.5	Insulation	99
6.6	LV and MV generators	100
6.7	Typical circuitry	100
6.8	Load types and Generator sizing	102
6.9	Generator earthing	102
6.10	Faults and protection	103
6.11	Performance evaluation and Testing	109
6.12	Summary	109

7	Diesel generating set assemblies	111
7.1	Coupling Requirements	111
7.2	Mounting Requirements	114
7.3	Layout Requirements	116
7.4	Paralleling of multiple DG sets	118
7.5	Standard Control panels	120
7.6	Synchronization Panels	124
7.7	Summary	125
8	Other components	127
8.1	Engine starting methods	127
8.2	Starting Characteristics	129
8.3	Step load requirements	131
8.4	Standby Requirements	132
8.5	Generator sizing	134
8.6	Starting-battery sizing	136
8.6	Auto start and Auto transfer schemes	136
8.7	Auto Transfer Switch (ATS)	138
8.8	Summary	139
9	DG power plant layout planning	141
9.1	Layout planning and its importance	141
9.2	Diesel generator configurations	143
9.3	Specific requirements in layout design for DG plants	144
9.4	Typical layout configurations of DG plants	146
9.5	Fuel storage system	149
9.6	Air Intake System	151
9.7	Exhaust System	151
9.8	Auxiliary power system	152
9.9	Summary	153
10	Testing and commissioning of DG power plants	155
10.1	Introduction	155
10.2	Factory Tests	156
10.3	Pre-commissioning checks	158
10.4	Pre-commissioning Tests	160
10.5	Performance Monitoring	162

10.6	Fuel and Lube oil Consumption Tests	163
10.7	Electrical system tests	164
10.8	Summary	166
11	Operation and maintenance of DG power plants	167
11.1	Safety Requirements	167
11.2	Maintenance Techniques	171
11.3	Operation Monitoring	173
11.4	Maintenance Philosophy	177
11.5	Maintenance Planning and scheduling	178
11.6	Spares and inventory Management	180
11.7	Maintenance tools	180
11.8	Inspection, overhaul and repair	182
11.9	Training of O&M personnel	188
11.10	Troubleshooting	189
11.11	Summary	191
Appendix A	Quality Assurance checklists	193
Appendix B	Course Exercises	207

Introduction

In this introductory chapter, we will discuss various sources of energy, the generation of electric power and the prime movers for power generation. We will briefly discuss the types of engines used, in particular the diesel engine and its advantages when used as prime mover in power generating plants.

Learning objectives

- Energy sources
- The choice between AC and DC power
- Single phase vs. three-phase AC power
- Prime movers used for power generation
- Power plant components/types
- Types of engines used in power generation
- Diesel engine and its advantages in power generation applications

1.0 Energy sources

The pioneering experimental work of Michael Faraday on electromagnetism and the dynamo (electrical generator), which he invented, paved the way for today's electrical power systems. The invention of the electric lamp by Thomas Edison was a major breakthrough in promoting the use of this new energy form for residential and commercial applications. The development of electric motors, which could be used as the drive for machinery, gave a further boost to its widespread use in all types of industrial applications. All these led to the establishment of centralized power generation facilities to produce electricity in an efficient way and carry it to human settlements for enhancing the standards of living and quality of life.

Electricity is produced in many different ways in today's world. The generation of electric power primarily involves conversion of some naturally available form of energy (such as chemical energy in a fuel) into electrical energy. It was in the year 1903, just over hundred years ago, that the first steam turbine generator, pioneered by Charles Curtis was put into operation at the Newport Electric Corporation in Newport, Rhode Island.

Steam still remains the main energy transfer medium in many power plants where it is produced by heating water in Steam Generating Units (commonly called ‘Boilers’) using a variety of fuels. Coal is still one of the major raw materials used for generating the super heated steam required for power plants.

Steam generating units and turbines powered initially by coal, later by oil, natural gas, and now by nuclear fission energy, took a major leap forward in the early decades of the 20th century. Simultaneously, key improvements were made in the design of generators to obtain higher energy efficiencies. By the year 1920, high-pressure steam generators were the state of the art. Initially, the common rate of power generation by steam pressure was 1 kilowatt hour (kWh) per 15 to 20 kg of coal. Within a short time period, this was reduced to around 2 kg of coal needed for producing 1 kWh with high steam pressure turbines.

The energy sources used for producing electrical power are broadly classified as:

- Conventional energy sources
- Non conventional/Renewable energy sources

Though electricity has been discovered for just over a century, dividing power generation sources as conventional and non conventional is due to the fact that there are quite a few sources having different characteristics used for generating electrical power, Power generation using conventional fuels involves combustion of naturally occurring fuels but the latter (renewable energy sources) may or may not require a combustion stage in the conversion process. Conventional energy production processes deplete naturally available resources such as petroleum, coal, etc., in addition to being major pollution contributors.

Electric power produced by various sources is based on the internal energy content per unit weight of the source and is termed in kilocalories per kg in metric units. This is called the calorific energy of the fuel and Table 1.1 lists the calorific values for some of the major sources used today.

Table 1.1
Typical Calorific values

Fuel	Calorific Value (kCal/kg)
Paraffin	10,400
Diesel Petroleum	9,800
Charcoal	7,100
Dried Wood	4,700
Lignite	4,000
Wood (25-30% Moisture)	3,500

The term non conventional energy generally refers to power generation methods that directly use the energy from natural resources like wind, Sun, etc., without depleting these resources and with minimum or almost zero pollution. These are also termed as renewable energy sources, since these sources do not deplete at the rates of conventional sources. Hydro-electric (hydel) generation is an example of renewable energy and forms one of the most important components of power generation in many countries around the world. Other more exotic methods such as power generation from tidal and wave energy

as well as from ocean thermal energy (deploying the temperature gradient of the sea water at different depths) are also under experimentation.

Though non-conventional sources are becoming popular in many countries, the bulk of the power generated today is created by using conventional fuel sources and results in depleting energy reserves. The use of diesel fuels belongs to the conventional generation category. While diesel oil can also be used for producing steam, this manual discusses diesel engine power plants where the electrical power is generated from diesel oil or an equivalent distillate produced from petroleum crude oil by an internal-combustion type of prime mover (engine), similar to those used in transport vehicles.

1.0 AC and DC power

Electrical power that is used in everyday life is broadly divided into two main categories viz., AC (Alternating Current) power and DC (Direct Current) power. In the case of DC power, the electrons flow in only one direction. In the case of AC power, the electrons oscillate back and forth at a defined frequency. Edison's inventions, from the light bulb to the electric fan, were based on DC electricity.

Though DC can be generated using DC machines with rotating armature and stationary field windings, the capacity is limited because of the need for a commutator/brush gear within the machine. Further, transmission of DC power over long distances cannot be as easily achieved as AC power. In today's world DC power is mostly derived from stationary batteries of Lead acid type, Nickel Cadmium type, etc. Naturally the sizes of these DC sources become unmanageable in high power applications. Hence the use of DC power is limited to standby power/ emergency use and starting applications.

Within a short span time since the invention of electricity, the advantages of AC power became apparent. AC power requires simpler and robust generator design and is also very easy to transmit over long distances. Although DC power continues to be used in equipment, it is invariably obtained by conversion. AC power can be readily converted to run DC appliances - another advantage offered by AC power.

The use of AC power became very widespread because of the invention of transformers, which can be used to convert the voltage easily to any desired value. Since transmission of power is more economical at higher voltages, AC power transmission and distribution systems deploying transformers have become the norm in the power industry. Transformers are also very useful as components within equipment where they are utilized to derive lower voltages to suit the application requirements. In modern power systems, transmission of power at high DC voltages has been found to possess specific advantages and is being used increasingly in specific segments. But this is more of an exception than the norm and is yet to attain the preminent position of AC systems in the power industry. The discussion of the same is beyond the scope of this manual.

1.3 Single phase and three-phase AC power

AC power is again divided into single phase and three-phase power. The first AC generators with a single set of windings and a rotating magnet generated single-phase voltage. Generators with spatially displaced windings generating poly-phase AC voltage were a later development. The advantages of three-phase power and the economy achieved in generation and transmission of electricity were then evident and it became the norm for all AC electrical systems. A single-phase power system results in higher current for transferring a given amount of energy, which increases the size of generators and also the conductors required to carry the current over long distances. Though single phase power is used today both in industries and commercial/residential applications, their

4 Diesel power generating plants

usage is limited to final distribution circuits for low capacity devices such as lighting, small pumps, small capacity air conditioners, computers, etc. Again, this single-phase power is actually derived out of the three phase system and does not require any special equipment / devices for separation of three phase power to single phase, when needed.

Today's power plants invariably generate three-phase AC power at hundreds and thousands of Megawatts.

The AC generator in a power plant is coupled to a prime mover, which is made to rotate (move) by its primary energy source, which can be a liquid fuel, gas, water (in hydroelectric power stations), etc. The prime mover drives the rotor of the generator at the required speed. This in turn produces an alternating voltage at the generator's three output terminals in sinusoidal form, which is the most commonly followed system for generation and transmission. (Zero to peak value to zero to negative peak to zero and repeating the same). The waveform in one of the phases will be as shown in figure 1.1, with time on the X-axis and the voltage value on the Y-axis. The arrow lines by the side of the waveform basically indicate its angular position at that particular time and the instantaneous value of the wave form is given by the vertical line length from the arrow end.

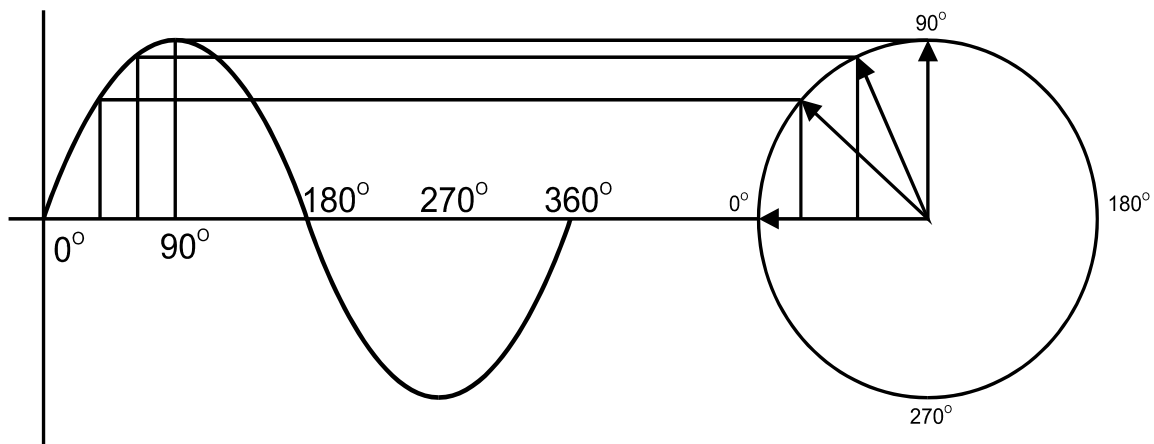

Fig 1.1
Ac sinusoidal voltage and vector representation

The above variation is termed one cycle with the voltage in one phase represented by a vector line, which makes 360° rotation for one full cycle. AC generators produce this kind of sinusoidal voltages at 50 or 60 cycles per second (known as the frequency of the electrical source and expressed in cycles/second or Hertz) in its three phases with B phase lagging A phase by 120° and leading phase C by 120° . Though the arrows are shown as moving in clockwise direction, it is generally a practice to show the vector traveling in anti clock direction. These three phases A,B and C are represented as three rotating vectors as shown in figure 1.2 below.

“Generator” is a common name used for both AC and DC producing machines. However for a quick understanding, the AC generator is more commonly called “alternator” meaning it produces alternating current, unlike its DC counterpart.

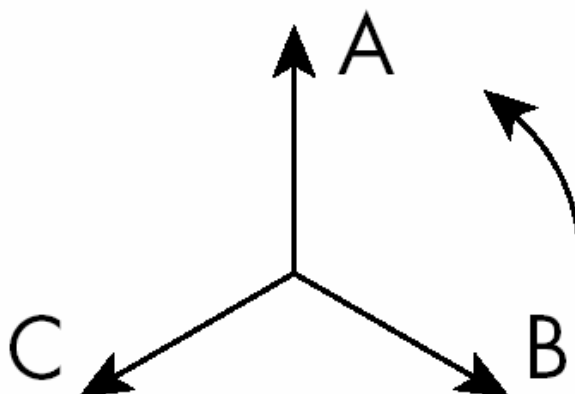

Fig 1.2
Regular anticlockwise phase voltage rotation

The generator is provided with three independent windings in such a way as to produce the voltages in the above fashion. The windings at one end are brought to terminals A, B and C and the other ends are interconnected to form the neutral end of the generator. Though the windings can also be connected in Delta form, this is not followed in generators. It is also an established practice to connect the neutral terminal to the ground through a resistance called Neutral Grounding Resistor (NGR) to limit the fault currents in the generator during earth fault. Further, it is to be noted that when multiple generators are connected to supply a common bus, the phase angles A, B and C of all generators shall be exactly same as otherwise it would lead to severe short circuit conditions. The other major parameter to be matched is the terminal voltage of parallel-operated generators, which shall be almost equal.

The power produced by the generator in a power plant is expressed in terms of kilowatts (kW) or megawatts (MW) of electrical power output that basically defines the capacity of the power plant. The frequency of these three phase alternating voltages is directly proportional to the speed at which the generator is made to run with the help of the prime mover. The most common frequencies are 50Hz and 60Hz and vary from one country to another, which means the 60 Hz generator shall have to run faster than a 50Hz generator.

The capacity of an alternator is termed in kVA, which is basically the product of generated voltage kV and the maximum current it can deliver. The current wave form generally lags the generated voltage wave form by an angle and the cosine of this angle is the power factor of the generator. Product of kVA and power factor gives the useful power that can be extracted from the generator for a particular type of load, with the balance power spent to overcome the reactive force of the load. The capacity of a power unit is given in terms of kW (or MW) which is the product of kVA and power factor of the generator, giving the useful power that can be produced from an unit. Where a power plant includes multiple of units, the total capacity of the power plant is the sum of all kW that can be produced by all generators.

The power capacity of the generator is actually related to the maximum shaft power of the engine to which it is couple to. In case of diesel engines, the capacity of the engine is termed in brake horse power (BHP). Though it may be possible to connect a higher kVA

generator to the engine, it does not serve any purpose and hence the generator capacity is matched to the engine BHP rating and alternator efficiency that gives the output rating of a power set. . The diesel generator output is also referred in terms of KW or MW (Some times in KWe, MWe to distinguish from the heat load), taking into account the actual power that can be utilized for inductive loads at some power factor (normally 0.80). The output power of a generator is dependent on the mechanical energy input provided by its prime mover i.e. the capacity of the turbine/ engine. However the voltage peak value generated is independent of the prime mover capacity and is mainly dependent on the internal construction of the generator. The effective sinusoidal AC voltage across any two of the terminals of the generator is named the rated voltage of the generator. This effective value is called the RMS value of the sine cycle and is given by peak voltage divided by $\sqrt{2}$.

The main components of the AC generator are:

- Stator
- Rotor
- Exciter/field

It can be indicated that the rated kW/MW power of the plant is produced at the selected generator voltage. Similar to the frequency, the selected voltages of the generators may also vary from one country to another and is normally chosen to match the standard system voltages followed in the country of the plant. The full load current ratings of the alternator decide the size of the conductors to be used in it and hence the alternator size increases with increase in current values. Hence it is customary to design higher kVA alternators to produce higher terminal voltages to minimize the current (= kVA/kV) and also conductor size. The larger the engine capacity, the generator kVA would be higher requiring a higher terminal voltage, to keep the current ratings low. However the upper limit of the alternator terminal voltage is normally limited due to manufacturing constraints which is around 25kV. Beyond this voltage, the generator size becomes very large and difficulties are faced in having insulated windings above this voltage within a compact space. A rated generator voltage of around 11kV to 17.5kV is more commonly adopted in power plants.

This manual covers the generator construction and applications in a subsequent chapter.

1.4 Prime movers

Conventional power generation approach generally involves converting the energy contained in fuels first into thermal energy in a combustion unit, then converting the thermal energy to mechanical energy by a prime mover, with the mechanical energy being converted to electrical energy by the generator. External combustion systems have different equipment for all the three steps of conversion. In internal combustion engine combustion and conversion of thermal to mechanical energy take place within a single equipment unit.

Following are the major prime movers used in conventional power plants.

- Steam turbine
- Reciprocating engine
- Gas turbine.

Steam turbine belongs to the external combustion category whereas the other two examples are of internal combustion type.

Table 1.2 lists the typical prime movers and the power range normally generated.

Table 1.2
Features of Different Prime Movers

Type	Output Range	Typical Fuels	Typical Heat to Power Ratio	Heat Output
Steam Turbine	0.5MW to 600MW	Any, but used for producing steam	3:1 to 10:1	Medium
Gas Turbine	0.5MW to 250MW	Natural gas, Liquified Gas, Biogas, Mine gas	1.6:1 up to 5:1 with after firing	High
Compression ignition engines	Upto 20 MW	Natural gas with diesel oil, Heavy fuel oil	1:1 to 1.5:1 up to 2.5:1 with after firing	Low and High
Spark Ignition	Up to 4MW	Natural gas, Landfill gas, Biogas, Mine gas	1:1 to 1.7:1	Low and High
Heat Recovery gas turbines	1MW to 100MW	Same as gas turbine	Down to 0.7:1	Meduim

The choice of prime mover is based on a number of factors and even with similar energy requirements, no two sites can be the same. The critical factor is the Heat to Power ratio of site demand, which is also listed, in the above table. Ignition Engines are preferred where the electrical power requirement is relatively high as a proportion of total energy of the plant in operation. Conversely where heat demand is typically more than 3 or 4 times electrical demand the turbine begins to have an advantage. Another key factor is the quality of heat required at the customer site. Some industrial processes have little use for low grade heat – the hot water produced in engine based schemes. Where high temperature steam is the primary heat requirement then the turbine is clearly superior.

However where the power requirements are by utility companies, the size of the power plant, access to fuel requirements, local conditions, etc decide the type of power plants. Invariably these units do not require steam as a major selling/utility product and hence these are mostly steam turbines and gas turbines. Engine driven power plants by utility companies are normally restricted, except in oil producing countries, because of the limitation in their sizes.

The following paragraphs give an insight of the major types of prime movers/ power plants.

Steam Turbines

Steam turbines have been used as prime movers for power plants for many years. The process generally involves production of High-pressure steam in a steam boiler. This steam is expanded within the turbine to produce mechanical energy rotating the turbine, which in turn drives an electric generator. This system generates less electrical energy per unit of fuel than a gas turbine or reciprocating engine-driven cogeneration system.

However its overall efficiency may be higher, achieving up to 84% (based on fuel gross calorific value).

For viable power generation, steam input must be at a high pressure and temperature. The plant is capital intensive because a high pressure boiler is required to produce the motive steam. Steam cycles typically produce a large amount of heat compared with the electrical output, resulting in a high cost installation in terms of dollars/kWe.

Gas Turbines

The gas turbine was the most widely used prime mover for large-scale cogeneration for many years, typically generating 1-100 MWe. Increased findings of gas fields in the second part of the last century have resulted in single turbine capacities exceeding 250MWe. The installation works of a gas turbine based system is much easier than installing steam turbine with high-pressure boiler. Increased availability of gases in many countries has given a boost to standalone gas turbine plants. The space requirements of gas turbine power plants are also considerably lower which is a factor weighing heavily in their favor. This, together with reduced capital cost and improved reliability of modern machines, often makes gas turbines the optimum choice in most of the modern plants.

Gas turbines are provided with compressors as an integral part. The fuel (which is normally natural gas) is burnt in a pressurized combustion chamber using combustion air supplied by the compressor that is integral with the gas turbine. The very hot (900°C - 1200°C) pressurized gases are used to turn a series of fan blades and the shaft on which they are mounted, to produce mechanical energy. The available mechanical energy is used to drive a generator to produce electricity, similar to the steam turbine.

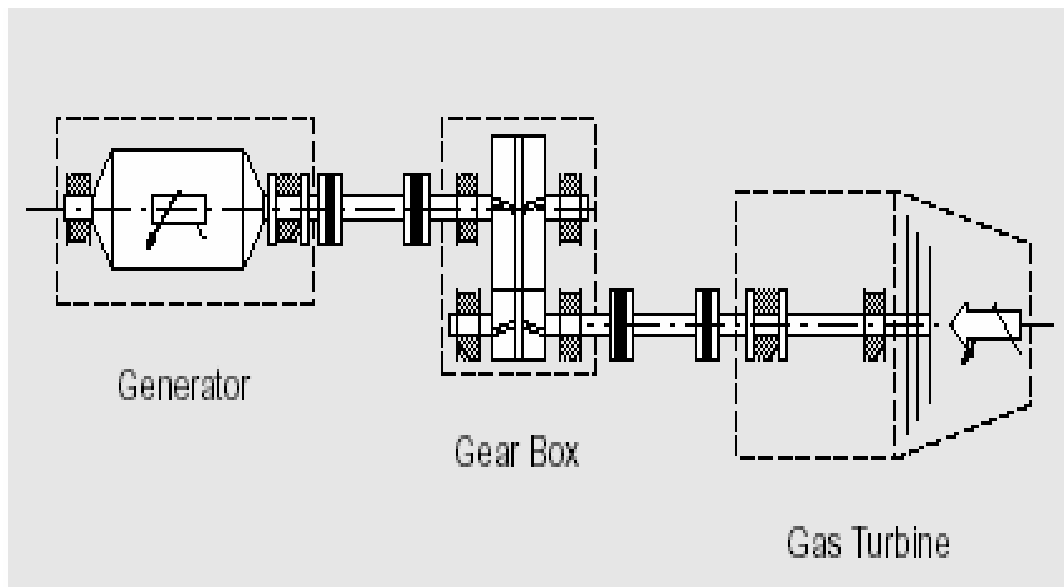

Fig 1.3
Gas Turbine Generator Components

A gas turbine generally operates under high speed and high temperature conditions. This necessitates use of high-premium fuels, particularly natural gas. The waste gases exhausted from the gas turbine are also quite high at around 450°C to 550°C , making the

gas turbine particularly suitable for high-grade heat supply. The ratio of usable heat to power varies from 1.5:1 to 3:1 depending on the characteristics of the particular gas turbine. Supplementary firing may also be used to increase exhaust gas temperatures to 1000^o C or more, raising the overall heat to power ratio to as much as 10:1.

Supplementary firing is highly efficient as no additional combustion air is required to burn extra fuel. Efficiencies of 95% or more are typical for the fuel burned in supplementary firing systems.

Gas turbines are available in a wide power output range from 500 kWe to over 200 MWe, although sets smaller than 1 MWe have been generally uneconomical due to their comparatively low electrical efficiency and consequent high cost per kWe output. The turbine is typically mounted on the same sub-base as its generator, with a step down gearbox between the two to reduce the high shaft speed of the turbine to a speed suitable for the generator related to its frequency output. A gas turbo-generator is extremely noisy due to the use of compressors and generally requires good acoustic enclosures for noise attenuation.

Combined Cycle Plants

It is possible to improve the efficiency of gas turbine installations by using a combination of gas turbine and steam turbine, in which, the hot exhaust gases from the gas turbine are passed through a Heat recovery Steam Generator (HRSG) to produce steam for the steam turbine. Plants employing this kind of mixed generation are called a combined cycle plants.

Gas turbine combined cycle (CCGT) systems are now adopted by utility companies where supplies of natural gas are plentiful. Power stations of up to 1,800 MWe have been constructed with multiple units. In some plants the steam produced is used for process or other heating duties and are named as cogeneration facilities (Electrical power and steam). The main advantage of CCGT cogeneration is its greater overall efficiency in the production of electricity.

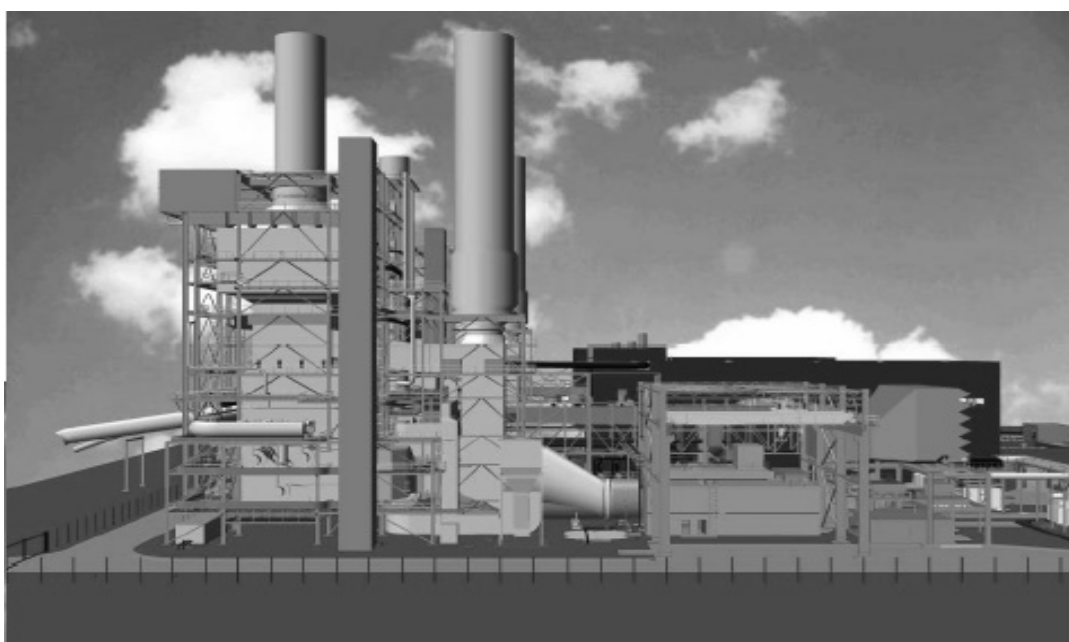

Fig 1.4
Combined Cycle Power Plant (Courtesy: ALSTOM)

The heat recovery boiler is an essential component of the cogeneration installation. It recovers the heat from the exhaust gases of gas turbines or reciprocating engines. The simplest one is a heat exchanger through which the exhaust gases pass and the heat is transferred to the boiler feed water to produce steam. The cooled gases are then passed through the exhaust pipe or chimney and are discharged into the atmosphere. In this case, the composition or constituents of the exhaust gases from the prime mover are not changed. The exhaust gases discharged contain significant quantities of heat but all can not be economically recovered with a boiler. One typical feature of the exhaust heat boiler (or waste heat recovery unit) is that the typical size is bigger than a conventional fuel-burning unit. This is because the lower exhaust gas temperatures require a greater heat transfer area in the boiler. It shall be ensured that excessive flow resistance in the exhaust gas stream is avoided as this can adversely affect the normal operation of the turbine or engine and its overall efficiency.

Reciprocating Engines

The diesel engines are basically reciprocating engines. Although conceptually the system differs very little from that of gas turbines, there are important differences. Reciprocating engines have a higher energy efficiency but the thermal energy they produce is generally at lower temperatures and is dispersed between exhaust gases and cooling systems. Hence heat recovery systems are uncommon in power plants employing reciprocating engines.



Fig 1.5
An Industrial skid mounted Diesel Generator

The usable heat power ratio range is normally in the range 0.5:1 to 2:1. However, as the exhaust contains large amounts of excess air, supplementary firing is feasible, raising the ratio to a maximum of 5:1.

There are two types of reciprocating engines commonly used for power generation,

- Compression-ignition ('diesel') engines – These are available as engines using diesel fuel as well as dual fuel type in which a small quantity of gas oil (about 5% of the total heat input) is injected with the gas to ensure ignition. Exhaust temperatures are often lower, typically 85^o C maximum, thereby limiting the scope for heat recovery. Compression-ignition engines run at speeds of between 500 and 1500 rev/min. In general, engines up to about 500 kWe (and sometimes up to 2 MWe) are derivatives of the original automotive diesels, operating on gas oil and running at the upper end of their speed range. Engines from 500 kWe to 20 MWe evolved from marine diesels and are dual-fuel or residual fuel oil machines running at medium to low speed.
- Spark-ignition engines – These are equivalents of diesel engines and have their same parameter equivalents as 90°C cooling water. Traditionally, shaft efficiency is lower than compression ignition engines. The output of a spark-ignition engine is a little smaller, typically 83% of the diesel engines. They are suited to smaller, simpler cogeneration installations, often with cooling and exhaust heat recovery cascaded together with a waste heat boiler providing medium or low temperature hot water to site. Spark-ignition engines operate on clean gaseous fuels, natural gas being the most popular. Exhaust fumes can be used directly in certain processes, such as drying, CO₂ production, etc.

Reciprocating machines by their nature have more moving parts, some of which wear more rapidly than those in normal rotating machines. These require running as well as shutdown maintenance for trouble free performance. Nevertheless, reasonably well-maintained sets can provide typical availability of about 90-95%, which makes them very attractive for industrial consumers.

1.5 Power plant components/types

The main components of any power plant are as below.

- Prime Mover
- Generator
- Fuel storage and handling system
- Cooling system
- Exhaust system
- Electrical substation and control

A power plant is generally known by the type of prime mover used to produce electric power. The other systems referred above are mostly support or auxiliary services to ensure efficient operation of the prime mover and for transferring the power efficiently. The prime mover is coupled to the generator directly or through gear boxes to produce the electric power.

The various prime movers commonly used to rotate a generator for electricity production are:

- Gas Turbines
- Steam Turbines
- Hydel Turbines
- Diesel Engines
- Gasoline Engines
- Heavy fuel engines, etc.

As can be noted, ‘turbine’ and ‘engine’ are the most common terms used to identify a prime mover. Table 1.3 compares the features of the various power generation methods presently in vogue.

Table 1.3
Features of Different power generation methods

Fuel/Prime mover	Advantages	Disadvantages	Remarks
Coal	<ul style="list-style-type: none"> ▪ Economical ▪ Good availability in many countries 	<ul style="list-style-type: none"> ▪ Cost not favourable for smaller sizes ▪ Coal properties not uniform and calorific values differ. ▪ More carbon dioxide (CO₂) per kWh of energy than any other generation method ▪ Ash disposal issues. ▪ Increased sulphur content in some types produce sulphur dioxide and eventually sulphuric acid that can cause acid rain. 	Coal being one of the main fuels used for a long time and hence still considered as a good fuel for generation though it does not have any space advantage over several other generation methods.
Natural gas	<ul style="list-style-type: none"> ▪ Lower capital cost. ▪ Compact sizes. ▪ Lesser CO₂ produced compared to coal or oil 	<ul style="list-style-type: none"> ▪ Cost not favourable for smaller sizes ▪ Natural gas reserves are limited and many times location closer to gas field is preferred in case of low availability. 	
Oil	<ul style="list-style-type: none"> ▪ Lower cost ▪ Compact Generators ▪ Produces less CO₂ than coal 	<ul style="list-style-type: none"> ▪ Limited oil reserves. ▪ Oil spills, especially at sea, cause severe pollution ▪ Some oils contain high levels of sulphur resulting in Sulphur dioxide and acid rains. 	Oil price increase causing major concerns in power cost.

Fuel/Prime mover	Advantages	Disadvantages	Remarks
Hydel	<ul style="list-style-type: none"> ▪ Compact size ▪ Pollution free 	<ul style="list-style-type: none"> ▪ Ecological unbalance due to large dams ▪ Dislocation of population for constructing dams. 	
Nuclear	<ul style="list-style-type: none"> ▪ Compact size 	<ul style="list-style-type: none"> ▪ Expensive ▪ Radiation release issues ▪ Plutonium used can be an indirect contributor for nuclear bombs ▪ Disposal of radio active materials 	
Wind Turbines	<ul style="list-style-type: none"> ▪ Non-polluting 	<ul style="list-style-type: none"> ▪ Dependent on wind ▪ Needs utility companies' backup 	
Diesel and petrol powered generators	<ul style="list-style-type: none"> ▪ Small in size ▪ Relatively low cost ▪ Portability ▪ Faster installation time 	<ul style="list-style-type: none"> ▪ Major noise and CO₂ producers. ▪ Fuels which are limited in availability 	Petrol engine limited to around 5 or 10kW. Diesel units are employed for higher sizes.
Solar photovoltaic (Solar electrical panels)	<ul style="list-style-type: none"> ▪ Abundant source ▪ Non polluting ▪ More useful for isolated locations 	<ul style="list-style-type: none"> ▪ Higher capital cost ▪ Mainly DC power and hence limited for smaller size units. ▪ High area requirements for large capacities. ▪ Need alternate power during nights and no sun days ▪ Cost of generation is high compared to other methods 	More useful in off shore installations.

In this manual we will cover the Diesel Engine operated power plants viz., diesel power plants which are used to generate Electrical power. Today diesel engines are available in many sizes but engines used for three phase power generation are mostly in the range of 7.5 kW to around 20000 kW.

1.6 Engine types

Engines may be classified as internal combustion engines and external combustion engines. Though external combustion is not common terminology, the basic steam turbine that is used in many power plants can be termed an external combustion engine. Here the power is generated by combusting the fuel external to the prime mover to produce steam, which is used by the turbine to generate power.

An internal combustion engine is an engine that is powered by the expansion of hot combustion products of fuel directly burnt within the engine. The internal combustion

diesel engine is piston operated, also called reciprocating. The internal combustion engine works by burning hydrocarbon or hydrogen fuel that is compressed by the piston action.

There are two primary reciprocating engine designs relevant to electrical power generation applications

- Spark ignition Otto-cycle engine
- Compression ignition Diesel-cycle engine.

The essential mechanical components of the Otto-cycle and Diesel-cycle are the same. Both the engines use a cylindrical combustion chamber in which a close fitting piston travels the length of the cylinder. The piston connects to a crankshaft that transforms the linear motion of the piston into the rotary motion of the crankshaft. Most engines have multiple cylinders that power a single crankshaft.

Spark ignition engines typically use a gaseous fuel such as natural gas or propane. Compression ignition engines typically use a liquid fuel such as Diesel. There are advantages and disadvantages to both in: fuel type, fuel consumption, power output, maintenance requirements and air emissions.

The primary difference between the Otto and Diesel cycles is the method of igniting the fuel. Spark ignition engines (Otto-cycle) use a spark plug to ignite a pre-mixed air fuel mixture introduced into the cylinder. Compression ignition engines (Diesel-cycle) compress the air introduced into the cylinder to a high pressure, raising its temperature to the auto-ignition temperature of the fuel that is injected at high pressure. The spark ignition engines usually have lower compression ratios. If the compression ratio of a spark engine is equal to that of compression ignition, uncontrolled combustion will result.

An engine's capacity is the displacement or swept volume by the pistons of the engine. It is generally measured in liters or cubic inches for larger engines and cubic centimeters (abbreviated to cc) for smaller engines. Engines with greater capacities are usually more powerful and provide greater torque at lower rpm's but also consume more fuel.

Apart from designing an engine with more cylinders, there are two ways to increase an engine's capacity. The first is to lengthen the stroke and the second is to increase the piston's diameter. In either case, it may be necessary to make further adjustments to the fuel intake of the engine to ensure optimal performance.

Spark ignition engines

The technology for spark ignited engines is based on natural gas fuel. These engines are bifurcated into two primary designs; lean burn and rich burn engines. The advantage of a lean burn engine is its greater fuel efficiency due to its inherently lower engine knock tendency and higher compression ratio. Since there is excess air during the combustion process, the CO emission level is also very low. The disadvantage of lean burn technology is the production of NO_x. Although, the NO_x production is lower in a lean burn engine than in a rich burn engine, it is very difficult and expensive to reduce the NO_x level from a lean burn engine with emission after-treatment systems. These systems use reagent-based NO_x-reduction catalysts or Selective Catalytic Reduction ("SCR") where ammonia or urea is added to the exhaust system. This requires a separate storage tank with additional operation costs.

Benefits of a lean burn engine compared to a rich burn engine:

- Greater fuel efficiency
- Lower emissions
- Higher power density

Rich burn engines compared to lean burn engines of the same size and configuration have only one advantage, the potential application of a Non Selective Catalytic Reduction ("NSCR") after treatment system. This technology has been commonly used in automotive applications for many years and is proven to reduce emissions by over 90% (CO, NO_x, unburned Hydrocarbons). It is also considered relatively inexpensive compared to other methods.

Compression ignition engines

Compression ignition engines are commonly called diesel engines, named after its inventor (Rudolf Diesel) who, in 1898, developed an engine using the principle of compression ignition. Since then, the fuel commonly used in the compression ignition engines or diesel engines has also been named "diesel fuel" though heavy fuels have been found to be more economical in operating diesel power plants in the last two/three decades.

The major features of the diesel engine are its ability to start quickly, pick up a large electrical load and run on a variety of stored liquid fuels. The greatest drawback to diesel engines is the high exhaust emissions. The emission quality typically is much poorer than that of a comparable spark ignition engine running on natural gas.

Compression ignition engines can also be fueled by a blend of diesel fuel with another fuel such as natural gas. These engines are commonly known as dual fuel engines.

The advantage of dual fuel engines are:

- Lower air emissions than a regular diesel engine
- Power density of a diesel engine
- Lower operating costs

Diesel engines have historically been the most popular type of reciprocating engine for both small and large power generation applications.

1.7 Diesel power plants

Diesel power plants comprise of diesel engines and other support systems typical of any power plant. Following paragraphs describe the basic components of the diesel engine and also the basic features of the support systems that are mostly common in an industrial atmosphere. These basic components and support systems will be covered in detail in the following chapters.

Engine components

The following are the essential components of an engine.

- Drive train: Basically refers to the pistons, connecting rods, crankshaft, flywheel, coupling, if any, and associated bearings of the engine.
- Valve train and timing: Includes the gearing from the crankshaft to the camshaft, Camshaft itself, push rods, rocker arms, valves, valve springs, and guides. The camshaft controls the fuel injection timing and actuates the injector in most of the engines with unit injectors in four-cycle engines. Two-cycle engines move air into the cylinder and exhaust out through ports in the cylinder wall which are exposed by the movement of the piston. Some two-cycle engines have both ports and valves. Injection timing and actuation on two-cycle engines are still controlled by a camshaft.

- Governor/control. The governor is a sophisticated device that controls the speed of the engine by varying the fuel input. The engine speed droops down when the load increases. A reverse phenomenon occurs when the load is suddenly thrown out. The governor gets the crankshaft speed feedback and reacts to small deviations in the speed due to the load changes and maintains proper engine speed by adjusting the amount of fuel injected. Two types of governors are more common on diesel engines driving electric generators. The earlier version was a self-contained mechanical-hydraulic type which is still under use. Developments in Electronics field have resulted in development of electronic governor with separate engine-mounted actuator. Multiple generating sets use Electronic governor systems to ensure proper load sharing. Pulsating loads of some facilities have dictated the use of mechanical governors. Plants adopting multiple engines must have compatible governors in each of them to ensure proper operation of engines in parallel.
- Turbocharger/blower: This is basically a centrifugal compressor, which is driven by the exhaust gases and in turn compresses the intake air to provide an increased mass of air to the combustion chamber. In-line engines typically have one turbocharger, and V type engines may adopt one or two turbochargers. Turbochargers are used on both two and four stroke engines, but many two stroke engines utilize blowers to assist in scavenging air from the combustion chamber without significant increase in the density of the air.
- After cooler: Turbocharged engines have an after cooler downstream of the turbocharger basically to reduce the air temperature and increase the density of the air entering the combustion chamber. Cooling water is circulated through the after cooler, which is composed of finned tubes to cool the air to approximately 40° C.

Engine supporting systems

The engine generating set requires a number of supporting systems. These are discussed below.

- Generators: AC generators are the main driven equipment for diesel engines in power plants. The diesel engine and the generator are generally coupled either directly or by means of a flexible coupling and correct alignment of the coupling is very critical for proper performance. It is important that the engine output and generator output are properly matched and a torsional analysis of the engine/generator system is performed by the engine manufacturer to ensure that there is no torsional resonance leading to shaft failures..
- Fuel oil systems: Like any prime mover, the fuel system is very important for continuous operation of the engine. The fuel oil must have the proper characteristics required for the specific engine installation. In general, less volatile fuels are employed for larger slow-speed engines while a more volatile fuel satisfies the performance of the smaller high-speed engines. Recent use of heavy fuel oils calls for special engine construction to meet the different characteristics of these fuels.

- Lube oil systems: All rotating machines require proper lubricating oil for satisfactory performance and prolonged life of the moving parts and diesel engines are no exception. Normally the manufacturer recommends the type of lube oil based on the fuels used and the engine characteristics. The lube oil must be analyzed at periodic intervals and changed based on the results of the analysis. The lube oil analysis also gives indirect indication of the problems or a need for maintenance of the moving parts. The analysis of the lube oil in large continuous plants should include trace metal analysis for early indication of abnormal wear to schedule maintenance or repairs, as needed. Lube oil systems are generally transferred from an internal sump of the engine generator set assembly cool and filters are used to provide proper lubrication and cooling of critical components within the engine.
- Engine air system: The engine intake and exhaust systems provide filtered air to the engine and remove products of combustion from the engine room respectively. These systems incorporate such features as preheating or pre-cooling of the intake air based on the plant sizes and the number of units in operation. Restrictions or blockage of the intake or exhaust system will severely hamper the engine performance. Pollution control requirements in many counties require installation of very tall chimneys for exhaust systems to ensure safe disposal of waste gases.
- Engine cooling system: The engine cooling system may consist of a single circuit which removes heat from the after cooler and lube oil cooler, as well as the engine, or it may have separate circuits which allow lower temperatures to be maintained at the various components. Radiator (Air) cooling is common for smaller sizes of around 500kW or less. The heat is usually rejected directly through a radiator or indirectly via a heat exchanger to a cooling tower. The cooling system temperature is thermostatically maintained to ensure proper cooling and avoid thermal shock of high-temperature components. The heat removed from the engine may be used to preheat combustion air in severe cold climates to improve the combustion process and also used for heating the power plant building in bigger power units.
- Engine starting air system: Majority of diesel engines installed in power plants are started with compressed air, though batteries are common for smaller size units used for industrial use. Compressed air is directed by a distributor directly into the combustion chamber or is provided to an air motor which rotates the engine. Dedicated compressors typically provide starting air at 250 psig. The system (either battery or air) must provide adequate storage to allow multiple attempts to start the engines.
- Engine control systems: The basic control of the engine is maintained by the governor during operation, and the control is independent for each engine. Possible control options range from local or manual starting and synchronization of each engine to automatic starting, synchronization, and load sharing of the engine generators.
- Instrumentation: In earlier days, generating plants used analog devices for measurement and control purposes. However many new plants now have automated data logging systems which can also provide warnings for out-of-tolerance conditions and historical records of unusual events which can improve the operation of the overall facility and support systems.

Regardless of the type of system, data collection provides the basis for trend analysis, which can indicate potential problems before they become severe.

- Ventilation system: Diesel engines operate at high temperatures and, therefore, reject large amounts of heat to the surrounding space. Diesel power plants are typically ventilated to remove this heat and to maintain engine room temperatures within acceptable limits for both personnel and equipment. Proper operation of ventilation systems is required to avoid excessive temperatures, reduced equipment capacity, and potential equipment failures.

Typical operation

Following are the various steps involved in starting up a diesel power unit.

- Initially the engine pre-lube pump should be run to ensure proper lubrication of the bearing surfaces. Where the engines remain idle like in standby/ emergency units, the pre-lube pump should be operated at regular intervals to keep the engine in "ready to start" condition. All engine auxiliary systems should be periodically checked to verify proper status for engine operation. Failure to properly pre-lube the engine prior to starting can result in damage to the internal components of the engine and significantly decrease engine life.
- The engine should then be started without any load connected to the generator (By keeping its main circuit breaker in open condition) and brought up to operating temperature before load is applied. The lube oil pressure shall be verified for normal range immediately after starting.
- Under normal circumstances, the engine loads are generally restricted between 50 percent to 100 percent load for extended periods of time. Operation at lower loads can cause carbon formation and rapid deterioration of the lube oil. Operation at high loads results in higher temperatures and pressures in the combustion chamber and can lead to more frequent maintenance or replacement of components. Priority should be given to maintaining correct lube oil and coolant levels and checking the pressure difference across the inlet air filters, fuel filters and lube-oil filters.
- Diesel engine should be unloaded and allowed to cool down prior to shutdown of the unit. The engine should be operated without load at rated speed for some time until the exhaust temperature decreases to recommended level and then at low idle speed for about five minutes without load or as directed by manufacturer.

1.8 Advantages of diesel power generation

Reciprocating engines are well suited to a variety of distributed generation applications. Commercial and institutional facilities commonly use diesel engines for their emergency power generation. The majority of industrial facilities also use the diesel engines for emergency applications, though use of diesel engines for continuous duty is more common in some process plants.

The major advantages of Reciprocating engines are

- Their installation time is very fast
- They start quickly when needed

- They follow the load well
- They have good part-load efficiencies
- They also ensure high reliability.
- Comparatively lower capital cost

In many cases, multiple reciprocating engine units are used to increase overall plant capacity and ensure better availability. Reciprocating engines have higher electrical efficiencies than gas turbines of comparable size resulting in lower fuel-related operating costs. In addition, the capital investments needed for installing reciprocating engine generating sets are generally lower than the capital cost for installing gas turbine generating sets up to 3-5 MW in size.

Though the reciprocating engine maintenance costs are generally higher than comparable gas turbines, the maintenance activities are invariably handled by in-house staff or provided by local established service organizations, making them attractive for industrial purposes.

Potential distributed generation applications for reciprocating engines include standby, peak shaving, grid support, and CHP (Combined Heat and Power) applications in which hot water, low-pressure steam, or waste-heat-fired absorption chillers are required. Reciprocating engines are also used extensively in applications such as water pumping, air and gas compressors and chilling/refrigeration, with the engines directly coupled to these machines thereby using the mechanical energy directly.

One of the major advantages of the diesel engine is its adaptability to different types of fuel varying from natural gas to light fuels to heavy residues (crude and furnace oils). They are also capable of burning liquid fuels derived from plants and biological wastes. Highly promising trials of community based generating plants based on bio fuels are underway in many countries and they are expected to give suitable alternative to the depleting oil reserves.

1.9 Summary

Electricity is produced in many different ways in today's world. It primarily involves conversion of some naturally available form of energy into electrical energy. Steam generating units and turbines powered initially by coal, later by oil, natural gas, and eventually by nuclear fission energy produce the bulk of electrical energy required all over the world. Power generation, transmission and distribution are done using 3-phase AC power. Power generation can either be done using conventional fuels or by renewable energy sources. The former involves combustion but the latter may or may not require a combustion stage in the conversion process.

Conventional power generation approach generally involves converting the energy contained in fuels first into thermal energy in a combustion unit, then converting the thermal energy to mechanical energy by a prime mover, with the mechanical energy being converted to electrical energy by the generator. External combustion systems have different equipment for all the three steps of conversion. In internal combustion engine combustion and conversion of thermal to mechanical energy take place within a single equipment unit. The diesel engine is one of the most versatile of internal combustion engines and is widely used in power generation. It is also considerably more efficient compared to the other alternative methods and has several practical advantages when used in certain types of power generation applications. We will discuss various aspects of Diesel Generating (DG) units in the chapters that follow.

