

Safe Operation and Maintenance  
of  
Circuit Breakers and Switchgear

## **THIS BOOK WAS DEVELOPED BY IDC TECHNOLOGIES**

### **WHO ARE WE?**

IDC Technologies is internationally acknowledged as the premier provider of practical, technical training for engineers and technicians.

We specialize in the fields of electrical systems, industrial data communications, telecommunications, automation and control, mechanical engineering, chemical and civil engineering, and are continually adding to our portfolio of over 60 different workshops. Our instructors are highly respected in their fields of expertise and in the last ten years have trained over 200,000 engineers, scientists and technicians.

With offices conveniently located worldwide, IDC Technologies has an enthusiastic team of professional engineers, technicians and support staff who are committed to providing the highest level of training and consultancy.

### **TECHNICAL WORKSHOPS**

#### **TRAINING THAT WORKS**

We deliver engineering and technology training that will maximize your business goals. In today's competitive environment, you require training that will help you and your organization to achieve its goals and produce a large return on investment. With our 'training that works' objective you and your organization will:

- Get job-related skills that you need to achieve your business goals
- Improve the operation and design of your equipment and plant
- Improve your troubleshooting abilities
- Sharpen your competitive edge
- Boost morale and retain valuable staff
- Save time and money

#### **EXPERT INSTRUCTORS**

We search the world for good quality instructors who have three outstanding attributes:

1. Expert knowledge and experience – of the course topic
2. Superb training abilities – to ensure the know-how is transferred effectively and quickly to you in a practical, hands-on way
3. Listening skills – they listen carefully to the needs of the participants and want to ensure that you benefit from the experience.

Each and every instructor is evaluated by the delegates and we assess the presentation after every class to ensure that the instructor stays on track in presenting outstanding courses.

#### **HANDS-ON APPROACH TO TRAINING**

All IDC Technologies workshops include practical, hands-on sessions where the delegates are given the opportunity to apply in practice the theory they have learnt.

#### **REFERENCE MATERIALS**

A fully illustrated workshop book with hundreds of pages of tables, charts, figures and handy hints, plus considerable reference material is provided FREE of charge to each delegate.

#### **ACCREDITATION AND CONTINUING EDUCATION**

Satisfactory completion of all IDC workshops satisfies the requirements of the International Association for Continuing Education and Training for the award of 1.4 Continuing Education Units.

IDC workshops also satisfy criteria for Continuing Professional Development according to the requirements of the Institution of Electrical Engineers and Institution of Measurement and Control in the UK, Institution of Engineers in Australia, Institution of Engineers New Zealand, and others.

## **CERTIFICATE OF ATTENDANCE**

Each delegate receives a Certificate of Attendance documenting their experience.

## **100% MONEY BACK GUARANTEE**

IDC Technologies' engineers have put considerable time and experience into ensuring that you gain maximum value from each workshop. If by lunchtime on the first day you decide that the workshop is not appropriate for your requirements, please let us know so that we can arrange a 100% refund of your fee.

## **ONSITE WORKSHOPS**

All IDC Technologies Training Workshops are available on an on-site basis, presented at the venue of your choice, saving delegates travel time and expenses, thus providing your company with even greater savings.

## **OFFICE LOCATIONS**

AUSTRALIA • CANADA • INDIA • IRELAND • MALAYSIA • NEW ZEALAND • POLAND •  
SINGAPORE • SOUTH AFRICA • UNITED KINGDOM • UNITED STATES

**[idc@idc-online.com](mailto:idc@idc-online.com)**

**[www.idc-online.com](http://www.idc-online.com)**

Visit our website for **FREE** Pocket Guides

**IDC Technologies produce a set of 6 Pocket Guides used by  
thousands of engineers and technicians worldwide.**

Vol. 1 – **ELECTRONICS**

Vol. 4 – **INSTRUMENTATION**

Vol. 2 – **ELECTRICAL**

Vol. 5 – **FORMULAE & CONVERSIONS**

Vol. 3 – **COMMUNICATIONS**

Vol. 6 – **INDUSTRIAL AUTOMATION**

To download a **FREE** copy of these internationally best selling pocket guides go to:  
**[www.idc-online.com/downloads/](http://www.idc-online.com/downloads/)**





*Technology Training that Works*

**Presents**

**Safe Operation and Maintenance  
of  
Circuit Breakers and Switchgear**

*Revision 6.1*

*Website: [www.idc-online.com](http://www.idc-online.com)*

*E-mail: [idc@idc-online.com](mailto:idc@idc-online.com)*

IDC Technologies Pty Ltd  
PO Box 1093, West Perth, Western Australia 6872  
Offices in Australia, New Zealand, Singapore, United Kingdom, Ireland, Malaysia, Poland, United States of America, Canada, South Africa and India

Copyright © IDC Technologies 2008. All rights reserved.

First published 2008.

All rights to this publication, associated software and workshop are reserved. No part of this publication may be reproduced, stored in a retrieval system or transmitted in any form or by any means electronic, mechanical, photocopying, recording or otherwise without the prior written permission of the publisher. All enquiries should be made to the publisher at the address above.

ISBN: 978-1-921007-37-8

### **Disclaimer**

Whilst all reasonable care has been taken to ensure that the descriptions, opinions, programs, listings, software and diagrams are accurate and workable, IDC Technologies do not accept any legal responsibility or liability to any person, organization or other entity for any direct loss, consequential loss or damage, however caused, that may be suffered as a result of the use of this publication or the associated workshop and software.

In case of any uncertainty, we recommend that you contact IDC Technologies for clarification or assistance.

### **Trademarks**

All logos and trademarks belong to, and are copyrighted to, their companies respectively.

### **Acknowledgements**

IDC Technologies expresses its sincere thanks to all those engineers and technicians on our training workshops who freely made available their expertise in preparing this manual.

# Contents

<b>1</b>	<b>Switchgear in a Network Context</b>	<b>1</b>
1.1	Single line diagrams	2
1.2	Active and passive components	2
1.3	Circuit breaker utilization	2
1.4	Forms of medium voltage switchgear	3
1.5	Basic circuit breaker design	5
1.6	Auto reclosing	8
<b>2</b>	<b>Switchgear in an Historic Perspective</b>	<b>13</b>
2.1	Plain break oil circuit breakers	13
2.2	Small oil volume circuit breakers	18
2.3	Air blast circuit breakers	19
2.4	Operating mechanisms	23
2.5	SF <sub>6</sub> and vacuum circuit breakers	23
2.6	Puffer type SF <sub>6</sub> circuit breakers	25
<b>3</b>	<b>Switchgear Rating and Specification</b>	<b>29</b>
3.1	Standards and factors affecting circuit breaker selection	29
3.2	Rated voltage $U_r$	30
3.3	Rated insulation level	31
3.4	Rated short time withstand current ( $I_k$ )	33
3.5	Rated peak withstand current ( $I_p$ )	34
3.6	Symmetrical and asymmetrical rating	34
3.7	Rated supply voltage of closing or opening devices ( $U_a$ )	35
3.8	Rated supply frequency of closing or opening devices	36
3.9	Stored energy operation	36
3.10	Locking and interlocking devices	36
3.11	Enclosure degrees of protection	37
3.12	Gas leakage rates	38
3.13	Testing for internal fault	40
3.14	Switchgear ancillaries, measurement CTs, VTs	44
<b>4</b>	<b>Protection</b>	<b>47</b>
4.1	Protection systems	47
4.2	Cable terminations	55
4.3	Substation and switch room layout and design	57
<b>5</b>	<b>Safety Policies</b>	<b>61</b>
5.1	Principles of safety rules	61
5.2	Operative training	62

5.3	Personnel levels of competency	63
5.4	Safety documentation	63
5.5	Work on live systems or close to live systems	64
5.6	Switching schedules	65
5.7	Special precautions when working on switchgear	69
5.8	Policies for operational and safety locking, safety notices and remote operation	72
5.9	Switchgear operation case studies	73
5.10	Substation inspection checklist	73
5.11	Personal protective equipment (PPE)	75
5.12	Fire protection in substations	77
<b>6</b>	<b>Asset Management in a Switchgear Context</b>	<b>79</b>
6.1	Overview	79
6.2	Insulation deterioration	85
6.3	Switchgear diagnostic techniques	87
6.4	Substation battery condition and monitoring	95
6.5	Switchgear maintenance procedures	104
6.6	Problems that may be found during switchgear maintenance	109
6.7	Defect management	109
6.8	Examples of switchgear defects	111
<b>7</b>	<b>Maintenance of Circuit Breakers</b>	<b>115</b>
7.1	The importance of adequate maintenance	115
7.2	LVCB on-site maintenance	116
7.3	Maintenance of molded case circuit breakers	117
7.4	Maintenance of low voltage circuit breakers	120
7.5	Maintenance of medium voltage circuit breakers	121
7.6	Electrical tests	125
7.7	Sf6 breakers	126
7.8	Summary	128
<b>8</b>	<b>Low Voltage Networks</b>	<b>129</b>
8.1	Introduction	129
8.2	Air circuit breakers	130
8.3	Molded case circuit breakers	130
8.4	Arc chutes	131
8.5	Thermal tripping methods	131
8.6	Hydraulic tripping methods	132
8.7	Precautions	135
8.8	Applications and selective co-ordination	136
8.9	Effect of point-on-wave occurrence- cascade systems	139
8.10	IES 4 polarized release	141
8.11	Time-current response curve	142



8.12	Typical LV distribution systems	143
8.13	Summary	143
<b>A</b>	<b>Need for Protection</b>	<b>145</b>
A.1	Need for protective apparatus	145
A.2	Basic requirements of protection	145
A.3	Summary	146
<b>B</b>	<b>Faults, Types &amp; Effects</b>	<b>149</b>
B.1	The development of simple distribution systems	149
B.2	Faults - types and their effects	151
<b>C</b>	<b>Simple Calculation of Short Circuit Currents</b>	<b>155</b>
C.1	Introduction	155
C.2	Revision of basic formulae	155
C.3	Calculation of short circuit MVA	158
C.4	Useful formulae	160
C.5	Cable information	161
<b>D</b>	<b>Case Study-Design of a Typical HV Switchboard Installation</b>	<b>167</b>
D.1	Preamble	167
D.2	Standardization	167
D.3	Inputs	168
D.4	Design step-1: Basic equipment configuration	170
D.5	Design step-2: Ratings of equipment and devices	171
D.6	Design step-3: Control interfacing	177
D.7	Design step-4: Board dimensions	178
D.8	Design step-5: Space requirements	178
D.9	Design step-6: Planning for other facilities	179
D.10	Design review	180
D.11	Conclusion	180
<b>E</b>	<b>Case Studies of Circuit Breaker Related Failures</b>	<b>181</b>
E.1	Case study 1: circuit breaker failure	181
E.2	Case study 2: turbine outage	182
	<b>Questions</b>	<b>185</b>
	<b>Answers</b>	<b>199</b>



## Switchgear in a Network Context

### 1.1 Single line diagrams

Figure 1.1 shows a typical example of a high voltage distribution network, represented as a single line diagram, complete with transformer infeeds, cable and overhead circuits, distribution substations, circuit breakers and other network switchgear. The term 'Single line diagram' simply means that the three phase nature of the circuits and components is ignored.

### 1.2 Active and passive components

Network components may be divided into two broad categories, those that are continuously in use whenever electricity is being supplied, called the **ACTIVE** components and those called upon to function only when required to do so, the **PASSIVE** components.

**ACTIVE** components comprise transformers, cables, overhead lines and metering equipment and may be considered the main revenue earning elements. **PASSIVE** components compose mainly switchgear in its various forms, together with switchgear's ancillaries, current and voltage transformers and protection relays. These components perform no revenue earning function and may be considered as an added cost, to be minimized wherever possible.

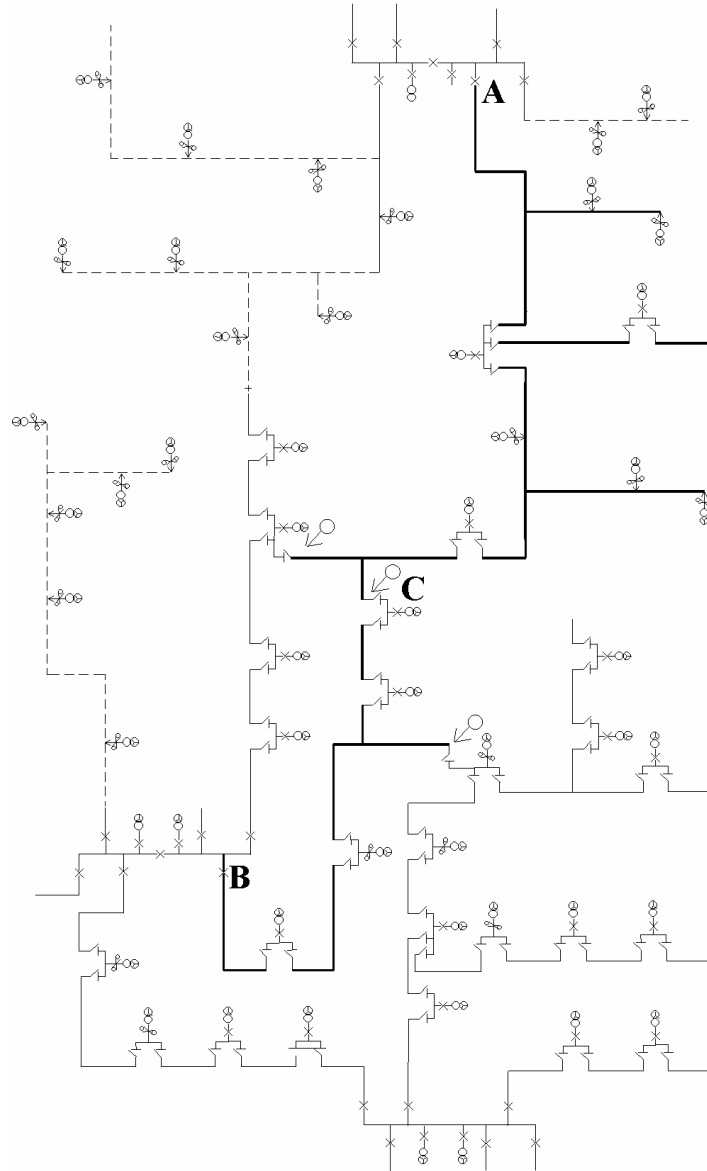

**Figure 1.1**  
*Typical network as a single line diagram*

### 1.3 Circuit breaker utilization

In an ideal network having perfect reliability and no maintenance or repair requirement, there is no need to break the electric circuits; however, this is impossible; therefore switchgear has to be installed. However, we should be careful not to install more switchgear than is absolutely required and the switchgear that is installed should have no more functionality than is necessary.

The two most common forms of medium voltage switchgear are automatic circuit breakers and non-automatic, load breaking, fault making switches. The main function of a circuit breaker is to automatically interrupt fault current, although an important secondary function is to close onto a fault and thereby make fault current. This function may be required during for example, fault location. The automatic disconnection of faults by circuit breakers allows the remainder of the network to continue in operation, after the faulty branch has been disconnected. Without this feature, network operation would be 'all or nothing'.

In theory all the switchgear shown in Figure 1.1 could be implemented by circuit breakers, but this choice would be very expensive and result in an excessive maintenance burden. In practice, circuit breakers are normally located only at the beginning of the cable, overhead line or mixed circuit, where they serve to disconnect faults either phase to phase or phase to neutral/earth (or both).

## 1.4 Forms of medium voltage switchgear

Historically, circuit breakers were also utilized at each distribution substation, to control and protect the transformer, although fuse switches may nowadays implement this function. Medium voltage fuses are available up to a current rating equivalent to a three phase rating of approximately 1.5 MVA and offer a cost-effective means of transformer protection. Generally they are combined with a three phase disconnecter and a 'trip all phases' device, so that if one fuse fails, the disconnecter trips and the supply to the transformer are fully disconnected. If this device were not fitted, the transformer may be subjected to 'single phasing' and a corresponding low LV side voltage (see Figure 1.2).

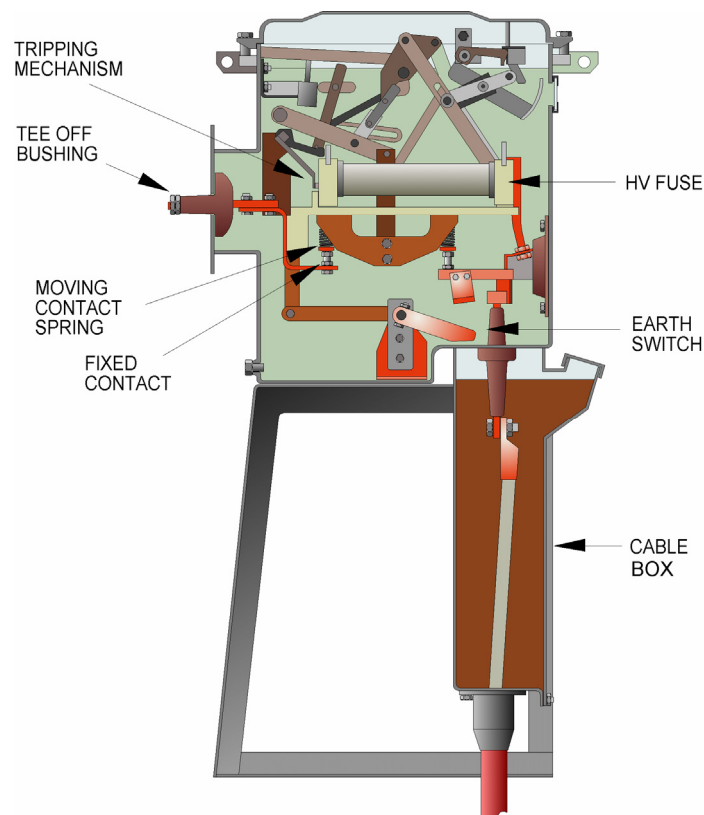

**Figure 1.2**  
*Fuse switch in cross section*

The remainder of the switchgear on the system shown in Figure 1.1 comprises non-automatic, load breaking, fault making switches. The main function of this form of medium voltage switchgear is to subdivide the circuit part of the network into smaller, more manageable sections, so that in the event of a fault, supply may be restored to a greater number of distribution substations, by manual switching. During switching operations, the precise location of, for example, a cable fault may not be precisely known and there is a possibility that a non-automatic switch may be closed onto a fault, hence the need to have a 'fault making' capability. An important secondary function of both circuit breakers and non-automatic switchgear is to allow safe access to the circuit conductors, thereby permitting the application of various cable fault location techniques.

Non-automatic load breaking, fault making switchgear may be implemented as separate switches, or linked together to form a switchboard, or they may be combined with a fuse switch or circuit breaker into a 'Ring Main Unit' (RMU).

Ring Main Units are commonly combined with transformers and LV switchgear to form what has become known as UNIT or COMPACT substations, delivered as completed products from the factory, needing only to be cabled up and commissioned.

Considering Figure 1.1 further, the circuit shown heavy line is typical of a supply circuit in an urban area. Each end of the circuit connects to a circuit breaker at Primary substations A and B, where supply is obtained from a higher voltage system. At an intermediate point, (marked C) a system 'open point' is implemented by non-automatic switchgear and the circuit is broken into two radial feeders. The extent of each radial may be varied by manual switching and further system flexibility is provided by additional 'open points' connecting to other circuits. It should however be appreciated that whilst the switchgear on network provides greater system flexibility and improves network reliability, it does so at considerable cost, including the cost of faults on the network switchgear itself and the cost of its periodic maintenance. In the typical network of Figure 1.1, more than 80% of all switching operations are likely to be caused by repair or maintenance requirements on other network switchgear.

Where circuits have many connected substations and hence a heavy load, it may be beneficial from a reliability standpoint to install a second circuit breaker at an intermediate point on the network, grading in its protection with the circuit breaker at the Primary substation. This arrangement offers automatic protection of supplies in the first half of the feeder, when faults occur in the second half. For example, in Figure 1.4, faults occurring beyond the location of the network circuit breaker at X will not cause loss of supply at substations between X and Y, if the protection settings of X are properly graded. However, there is the disadvantage that, as the protection is time graded, all faults on the circuit will take a longer time to clear, due to the need to set circuit breaker Y to a longer setting.

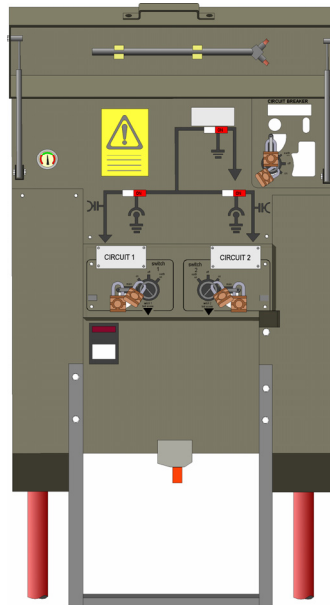

**Figure 1.3**  
*Ring main Unit - Schneider RN2C*

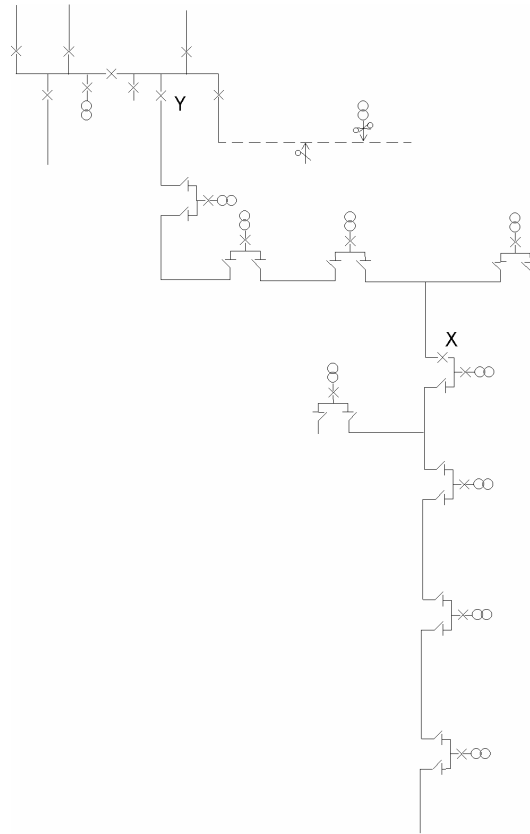
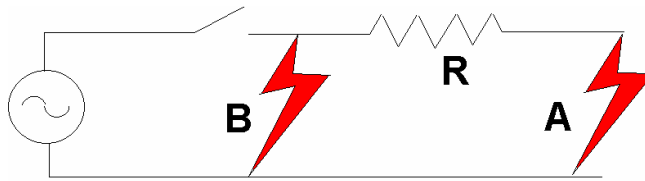

**Figure 1.4**  
*Supplementary circuit breaker*

## 1.5 Basic circuit breaker design

Although a circuit breaker may carry out various secondary functions, its primary purpose is to interrupt fault current automatically. The main problem of arc extinction and hence current interruption may be stated as ensuring that the dielectric strength across the contact gap exceeds the impressed voltage across the gap at time of current zero. To interrupt a circuit where the current is a few hundred amperes and the power factor is close to unity is not a problem, but it becomes a problem where the current is thousands of amperes and the power factor is low.

Consider the circuit shown in Figure 1.5.



**Figure 1.5**  
*Local and distant faults*

For the distant fault shown at A, circuit impedance, mainly resistance, acts to limit the fault current and bring the power factor to a value close to unity. As the voltage and current are almost in phase, the voltage across the open contacts of the circuit breaker is low at the time of current zero; hence the probability of arc extinction is high. This is illustrated in Figure 1.6.

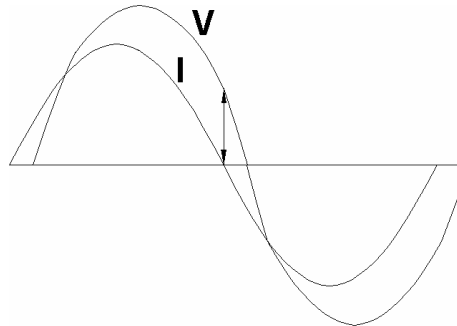

**Figure 1.6**  
*Phase relationship for a distant fault*

In the case of fault B, close to the circuit breaker terminals, generator reactance predominates and the power factor is low, perhaps 0.15. Thus at the time of current zero, when the circuit breaker acts to interrupt the fault, the voltage across the opening contacts is high. The high voltage across the open contacts at time of natural current zero makes interruption more difficult and there is a probability of the arc re-striking. This is shown in Figure 1.7.

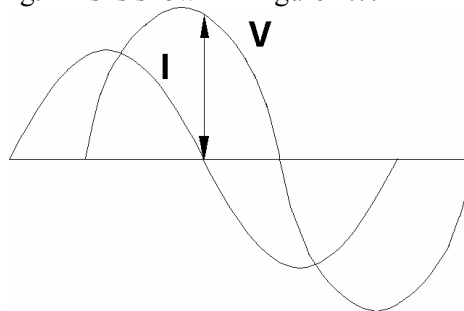

**Figure 1.7**  
*Phase relationship for a close fault*

As the contacts continue to separate, the arc length increases and the dielectric strength of the gap increases, according to the particular design of the circuit breaker. To limit the fault duration and hence damage, arc extinction and fault current interruption should occur at the earliest possible current zero, of which there are two in each current cycle. In practice, this ideal is not always achieved and depending upon the type of circuit breaker, the magnitude of the fault current and the power factor, several current cycles may occur before interruption is achieved. It is also highly desirable that fault current is not interrupted at any time other than a natural current zero; if it is, the



effect is called 'current chopping'. This effect is a practically instantaneous collapse of current that can lead to severe over-voltages and system damage. It is an acute problem when the circuit breaker has to deal with very low current values, for example transformer magnetizing current or capacitive line charging current.

During arcing, the voltage across the open contacts is known as the arc voltage and is relatively low with heavy current, short length arcs. In Figure 1.8 it is shown as  $V_a$  and at the instant of current zero it rises rapidly to the value of the peak value of the re-striking voltage transient. This voltage oscillates around the 50 Hz recovery voltage at a frequency that depends upon the resonant frequency of the system, determined by circuit R and X.

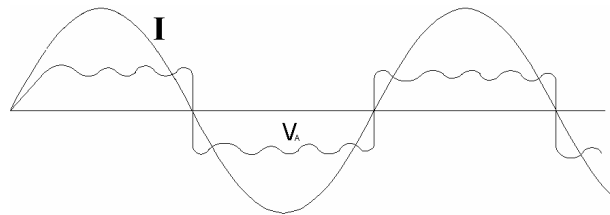

**Figure 1.8**  
*Variation of arc voltage with time*

This oscillating voltage merges by damping into the recovery voltage at normal frequency, but its value is important in circuit interruption. This value may be affected by the value of the peak voltage at 50 Hz as shown in Figure 1.8 but it is also affected by the nature of the fault. For example, in Figure 1.9 the blue phase has cleared whilst the remaining two phases are still connected via the circuit breaker arcs.

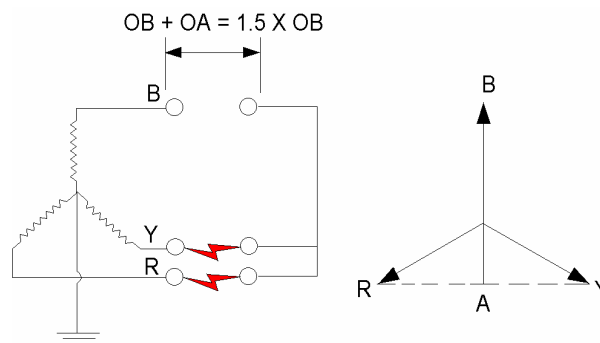

**Figure 1.9**  
*Effects of different clearance times on three-phase fault*

In the situation shown in Figure 1.9, where the neutral, or the fault or both are not earthed, the instantaneous voltage across the first circuit pole to clear will be 50% greater than the line to neutral peak. Thus the instantaneous value of the re-striking voltage may reach  $2 \times 1.5 \times$  phase to neutral volts. In practice, two or more natural frequencies may be present across the open contacts, resulting in a composite frequency as shown in Figure 1.10.

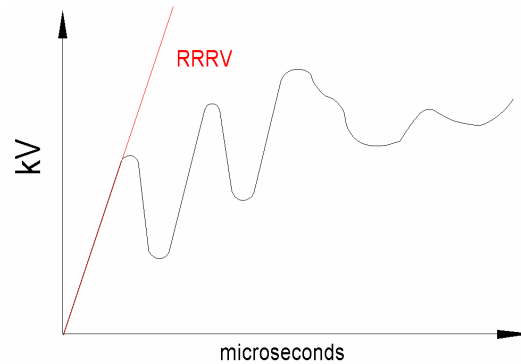

**Figure 1.10**  
*RRRV*

The rate of rise of recovery voltage (also known as RRRV and measured in volts per microsecond) is a factor that greatly affects circuit breaker performance; its value may be obtained by drawing a straight line through zero and tangential to the steepest part of the curve.

Some forms of circuit breaker are particularly sensitive to re-striking voltage, notably air blast circuit breakers. For this reason, what is described as resistance switching has been resorted to in axial blast designs. Resistance damps the oscillation of the arc voltage and is obtained by switching resistance in during the arc interruption process. Early designs of vacuum circuit breaker were prone to current chopping, but this effect has been eliminated with improved contact designs.

## 1.6 Auto reclosing

In networks comprising substantial lengths of overhead line, many of the faults that occur will be transient in nature. These are caused for example by wind blown debris bridging conductors, insulator flashover, etc. The reliability of the supply may be considerably improved by arranging for the controlling circuit breaker (at R in Figure 1.11) to re-close automatically after a fault occurs. This ensures that for transient faults, the restoration time is measured in seconds, rather than the hours it might take for an engineer to travel to the substation and re-close the circuit breaker manually.

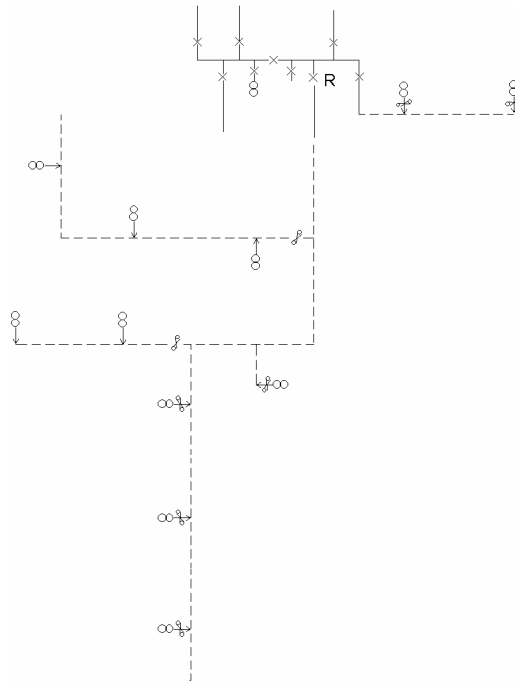

**Figure 1.11**  
*Re-closed overhead line network*

On overhead line networks, most transformers and spur lines are protected by medium voltage expulsion type fuses to BS 2692 (no IEC equivalent) and it will be necessary for the protection/re-close relay of the circuit breaker controlling the circuit to grade with these fuses. This ensures that where a fault on a connected transformer or spur line is permanent, the circuit breaker will close for long enough to allow the fuse to blow, before the circuit is re-energized. Fitting the circuit breaker with a timing mechanism to provide, for example, two instantaneous trips and two delayed trips fulfils these requirements. The timing sequence adopted varies according to local conditions, but Figure 1.12 shows a typical arrangement.

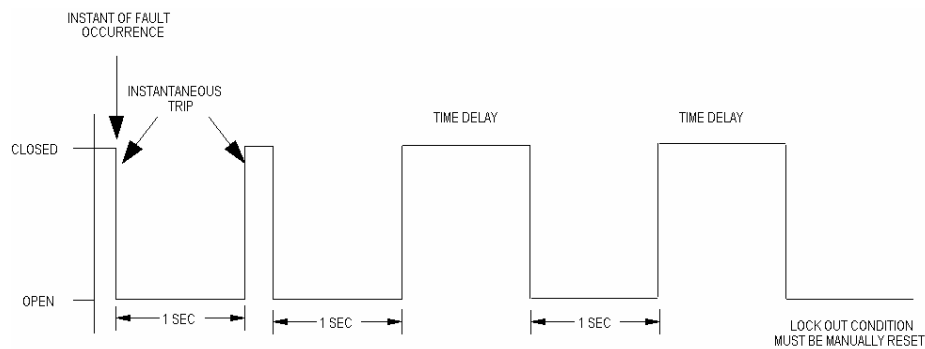

**Figure 1.12**  
*Typical auto re-close sequence*

The timing sequence is described as follows. At the instant when the fault occurs, the circuit breaker trips immediately and remains open for 1 second. This period is intended to allow for any ionized gases to clear. The circuit breaker then attempts a first re-closure. If the fault is still present, the circuit breaker trips again and remains open for a further 1 second. The second re-closure then occurs, but this time, if the fault is still present, tripping is delayed. This is because the system assumes that the fault lies beyond a fuse or fuses and it therefore allows sufficient time for the fuse(s) to rupture. If fault current still persists, a third re-closure is attempted, again with delayed tripping.

After this, the system assumes that the fault is permanent and 'locks out'. It must be re-set either manually or over a telecontrol system. If the fault is cleared at any time during the sequence, the system re-sets itself automatically, ready for the next fault and re-closure sequence.

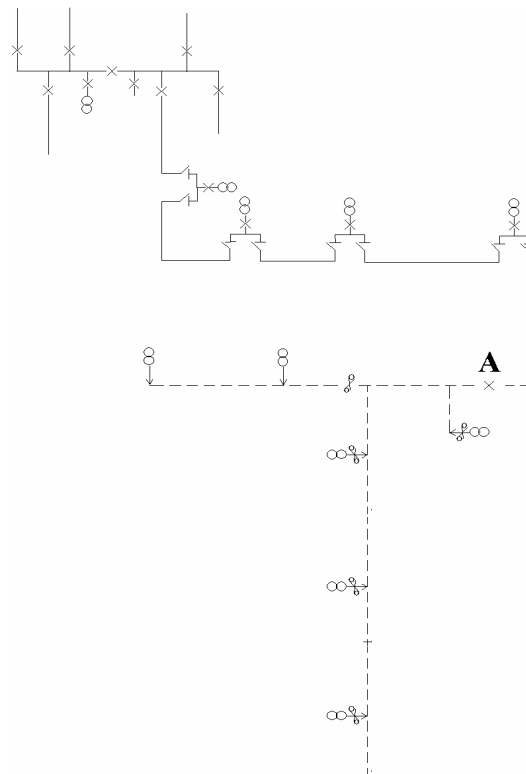

**Figure 1.13**  
*Pole mounted auto-recloser (at A)*

The satisfactory operation of a re-closed circuit breaker in association with fuses depends upon the degree of co-ordination obtained, requiring that the time/current characteristic of the re-closed circuit breaker be graded with those of the fuses to give optimum discrimination. The first trips must be short enough that the fuses are not degraded, whilst the second and third must be long enough to allow the fuses to operate.

It should be appreciated that whilst re-closing is not a problem for vacuum and SF<sub>6</sub> circuit breakers, oil circuit breakers have a very limited re-closing capability, depending upon the fault level. Normally, the number of re-closures that may be performed by an oil circuit breaker is programmed into the controlling auto re-close relay and when that limit is reached, further auto-reclosing is prevented until the circuit breaker has been maintained. The advice of manufacturers should be obtained when deciding upon the number of re-closures a particular design of oil circuit breaker may perform.

A disadvantage of re-closed circuit breakers is that, where the controlled network comprises both overhead line and cable, the supply to cable supplied customers will be adversely affected by re-closing operations caused by faults on the overhead network. In practice, this means that the customers on the cable network will experience momentary losses of supply, which they would not experience if the network were not re-closed. In addition, in the case of cable and plant faults, the additional fault closures may well cause additional damage. This effect can be reduced by good network design, or alternatively a pole-mounted re-closer may be used, as shown in Figure 1.13. In the network shown in Figure 1.13, the cabled part of the network is controlled by a circuit breaker not fitted with auto-reclose, whilst the overhead line part of the network is controlled by the pole

mounted auto recloser at point A. Originally, oil filled pole-mounted reclosers were used for this purpose, but vacuum and SF<sub>6</sub> designs are now available.

Figure 1.14 shows a sectional view of a typical pole mounted, oil filled auto recloser, together with a basic circuit diagram. This particular design, comprising all three phases in a common tank, was manufactured in large quantities and remains in service, although SF<sub>6</sub> and vacuum designs have superseded it. It features two instantaneous trips plus two delayed trips, the latter controlled by oil dashpots. Both overcurrent and earth fault protection are fitted; the latter can be switched out if required.

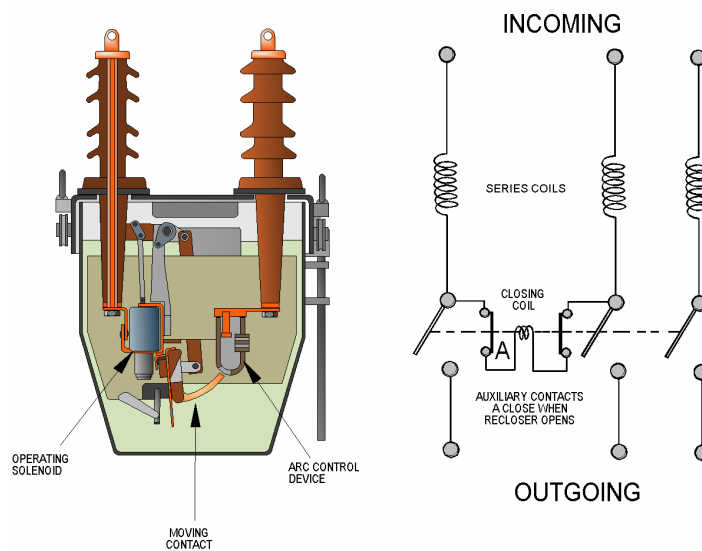

**Figure 1.14**  
*Pole mounted, oil filled recloser*

The energy to charge the spring mechanism of the recloser is derived from the circuit itself, so as to avoid the need for auxiliary low voltage supplies. Passage of fault current through the series overcurrent coils causes the recloser to OPEN and the trip sequence (normally two instantaneous, two delayed) to be performed automatically, proceeding to lock-out if appropriate. The energy to re-charge the spring mechanism is derived from a solenoid, operating through its own auxiliary contacts that CLOSE when the main contacts are OPEN and OPEN when the main contacts are CLOSED. When the solenoid is energized, it pulls in its iron armature until almost at the end of the solenoid stroke; the auxiliary contacts are caused to OPEN. The solenoid de-energizes and the iron armature is released, until the auxiliary contacts again CLOSE. The OPEN and CLOSE action is repeated approximately seven times, causing the spring mechanism to charge through a clutch and ratchet device. *Note that this device must be correctly installed as regards the source of supply; it will not operate in the reverse configuration.*

As the spring mechanism charges, a rotating cam is moved to a position where, just after the last charging stroke, the spring is discharged, closing the recloser. In the event that the fault is permanent, the recloser locks out and may then only be re-set manually, using a long insulated rod. Sequence timing for the two delayed operations is obtained by an oil dashpot, which for the instantaneous operations is by passed by a piston valve. The position of the piston valve determines whether the closure is immediate or delayed and is controlled by a sequence cam; by varying the position of this cam, the number of immediate and delayed trips can be varied.

Earth faults are detected by a core balance protection system, derived from ring type CTs and operating a tripping coil through a rectifier. Earth fault type operation is always immediate, no delayed tripping is allowed.

Although pole mounted oil filled reclosers of this type can perform a very useful network function, they have a limited fault rating (typically 50 to 100 MVA) and also require frequent maintenance. These problems are reduced by more modern SF<sub>6</sub> and vacuum types, which are usually microprocessor controlled and powered by long life Lithium batteries.

The type of recloser shown in Figure 1.15 is a great operational advance on the oil filled design that was described earlier. Maintenance requirements are low and the unit may be regarded as almost maintenance free, at least so far as the user is concerned, being limited to simple replacement of the primary battery at perhaps 5-year intervals. The vacuum interrupters will provide hundreds of reclosers; eventually, replacement will be required but this is a return to factory operation. A further advantage is that the bushings are elastomeric and less readily damaged than porcelain, either during installation or in service.

In these units the control system is normally sited in a lockable metal box close to ground level, remotely from the recloser proper and connected to it by a multicore (umbilical) cable. Because the protection system is microprocessor controlled, any number of possible reclosure strategies may be implemented, exactly as the operator requires and in addition, the unit is easily re-programmed to suit changing operational circumstances.

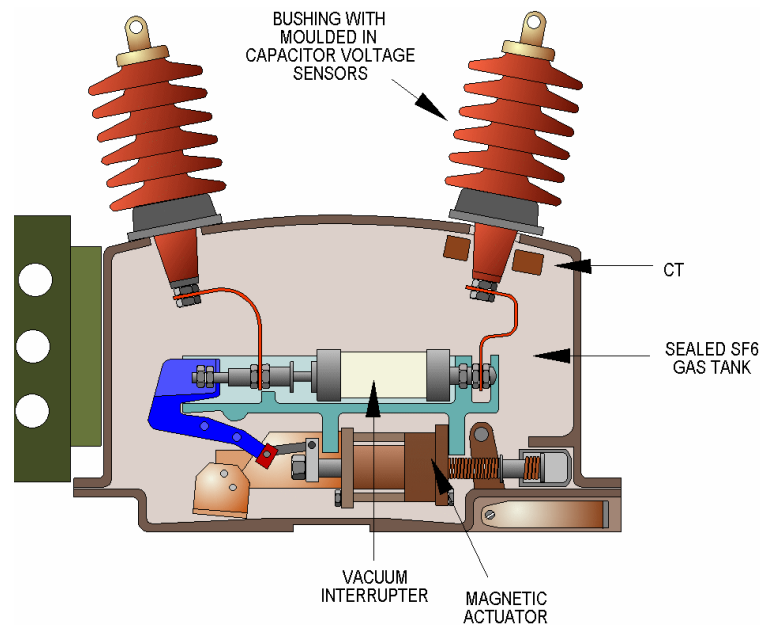

**Figure 1.15**  
*Vacuum interrupter in SF<sub>6</sub> auto-recloser*